

MODEL : LK-1941/LK-1942

List No : 1283-10

# PARTS LIST

Published:02/15/2019

## CONTENTS

---

FRAME & MISCELLANEOUS COVER COMPONENTS(1).....	1
FRAME & MISCELLANEOUS COVER COMPONENTS(2).....	5
MAIN SHAFT & NEEDLE BAR COMPONENTS.....	9
PRESSER LIFTER COMPONENTS.....	13
PRESSER MECHANISM COMPONENTS(FOR LK-1942).....	15
SHUTTLE DRIVER SHAFT & HOOK SHAFT COMPONENTS.....	19
WIPER MECHANISM COMPONENTS.....	23
TENSION RELEASE & THREAD TENSION COMPONENTS.....	25
TENSION RELEASE & THREAD TRIMMER MECHANISM COMPONENTS(1).....	29
TENSION RELEASE & THREAD TRIMMER MECHANISM COMPONENTS(2).....	33
FEED MECHANISM COMPONENTS.....	37
CLOTH FEED MECHANISM COMPONENTS.....	41
LUBRICATION COMPONENTS.....	43
THREAD STAND COMPONENTS (EXCEPT FOR AW-2D).....	47
CONTROL BOX COMPONENTS.....	49
OPERATION BOX & PEDAL COMPONENTS.....	53
HEATER UNIT COMPONENTS (Z TYPE).....	55
EXTENSION CABLE COMPONENTS.....	57
WIRING DIAGRAM.....	59
ACCESSORIE PART COMPONENTS.....	61
TABLE COMPONENTS (EXCEPT FOR AW-2D).....	65
OPTIONAL PART COMPONENTS(1).....	67
OPTIONAL PART COMPONENTS(2).....	71
LIST FOR INFORMATION OF CHANGE.....	73
HOW TO MAKE USE OF THIS PARTS LIST.....	74

FRAME & MISCELLANEOUS COVER COMPONENTS(1)

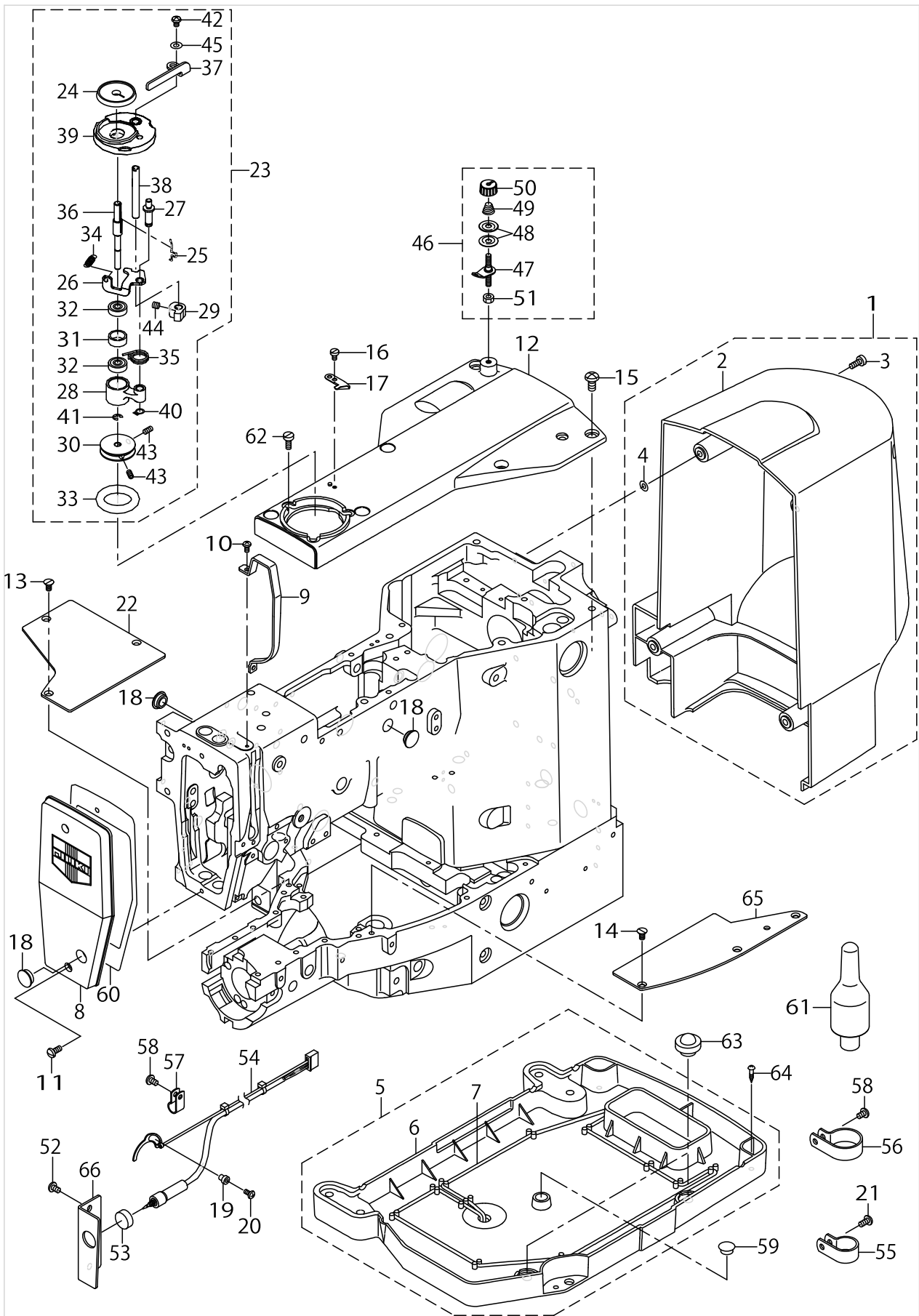

FRAME & MISCELLANEOUS COVER COMPONENTS(1)

No.	Parts No.	Parts name	Remarks	Level	Cons	Qty
1	14100457	MOTOR COVER ASM.				1
2	14100408	MOTOR COVER		*		1
3	SS6111140SP	SCREW 11/64-40 L=11		*		4
4	M8002430000	STOPPER		*		4
5	14100754	OIL PAN ASM.				1
6	14100705	OIL PAN		*		1
7	CQ252200000	OIL WICK		*		1
8	26211755	FACE COVER ASM.				1
9	40030828	THREAD_TAKE_UP_LEVER_COVER				1
10	SS4090715SP	SCREW 9/64-40 L=7				2
11	SS4111015SP	SCREW 11/64-40 L=10				2
12	14100309	TOP COVER				1
13	SS1110840SP	SCREW 11/64-40 L=8				3
14	SS1110840SP	SCREW 11/64-40 L=8				3
15	SS4151215SP	SCREW 15/64-28 L=12				6
16	SS4090715SP	SCREW 9/64-40 L=7				1
17	10502300	THREAD CUTTER				1
18	TA1250406R0	RUBBER PLUG D=12.5 L=4				3
19	B2703210000	BUSHING				1
20	SS4090715SP	SCREW 9/64-40 L=7				1
21	SS4110915SP	SCREW 11/64-40 L=9				1
22	14200802	BED COVER A				1
23	40020225	BOBBIN WINDER UNIT				1
24	14443006	BOBBIN SEAT		*		1
25	14443105	BOBBIN STOPPER SPRING		*		1
26	26260208	BTW_CAM_PLATE		*		1
27	26260307	BTW_BASE_SHAFT		*		1
28	26260406	BTW_SHAFT_BASE		*		1
29	26260505	BTW_CAM_LEVER		*		1
30	26260604	BTW_WHEEL		*		1
31	26260802	BTW_BEARING_SPACER		*		1
32	26261305	BTW_BEARING		*		2
33	26261503	BTW_WHEEL_RUBBER		*		1
34	26261701	BTW_SPRING		*		1
35	40011144	BTW_TORSION_SPRING		*		1
36	40022222	BTW SHAFT		*		1
37	40022224	BTW LEVER		*		1
38	40222225	BTW_LEVER_SHAFT		*		1
39	40022226	BTW BASE		*		1
40	RC0560711KP	RETAINING RING		*		1
41	RE0400000K0	E-RING 4		*		1
42	SM5030655SN	SCREW M3X0.5 L=6		*		1
43	SM8040802TP	SCREW M4X8		*		2
44	SM8050502TP	SCREW M5 L=5		*		1
45	WP0330516SC	WASHER 3.3X8X0.5		*		1
46	23636657	BOBBIN THREAD TENSION ASM.				1
47	14113450	BOBBIN THREAD TENSION ROD ASM.		*		1

FRAME & MISCELLANEOUS COVER COMPONENTS(1)

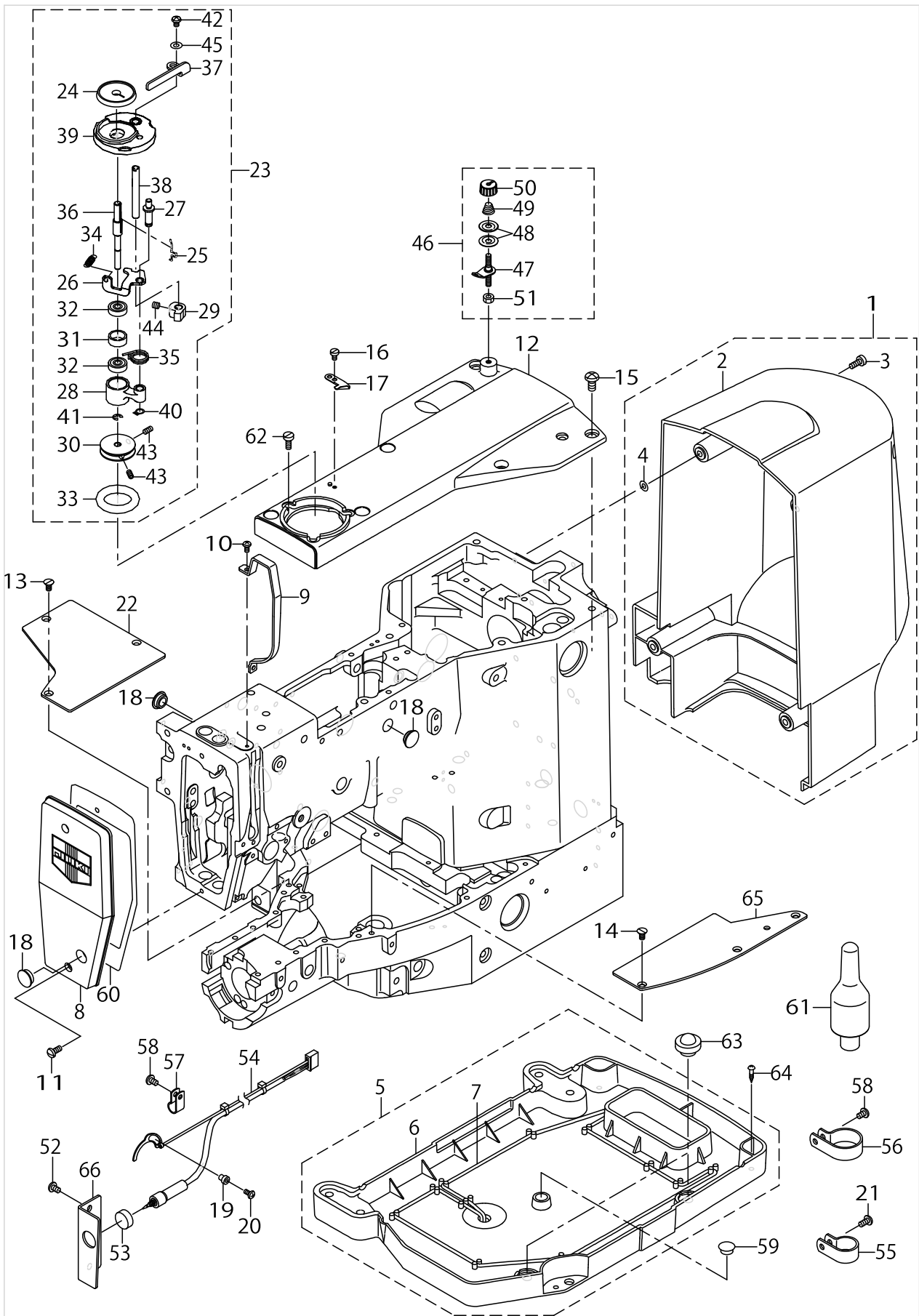

FRAME & MISCELLANEOUS COVER COMPONENTS(1)

No.	Parts No.	Parts name	Remarks	Level	Cons	Qty
48	B3126012000	THREAD TENSION DISK		*		2
49	D7133555B00	CONNECTING ROD SPRING		*		1
50	11072402	THREAD TENSION NUT		*		1
51	NS6110530SP	NUT 11/64-40		*		1
52	SS4110715SP	SCREW 11/64-40 L=7				2
53	HA001690010	SWITCH				1
54	14220750	SWITCH CABLE ASM.				1
55	HX00150000N	CABLE CLIP				1
56	HX00150000J	CLIP				1
57	HX00150000E	CORD PRESSER 3-POLE (220/240V)				3
58	SS4110715SP	SCREW 11/64-40 L=7				4
59	TA1050504R0	RUBBER PLUG				1
60	13502307	FACE PACKING				1
61	14101208	HEAD SUPPORT BAR				1
62	SS6111140SP	SCREW 11/64-40 L=11				3
63	B1116210D00	FRAME SUPPORT RUBBER				2
64	SK3382001SE	SCREW D=3.8 L=20				4
65	14200901	BED COVER B				1
66	14220503	SWITCH INSTALLING PLATE				1

FRAME & MISCELLANEOUS COVER COMPONENTS(2)

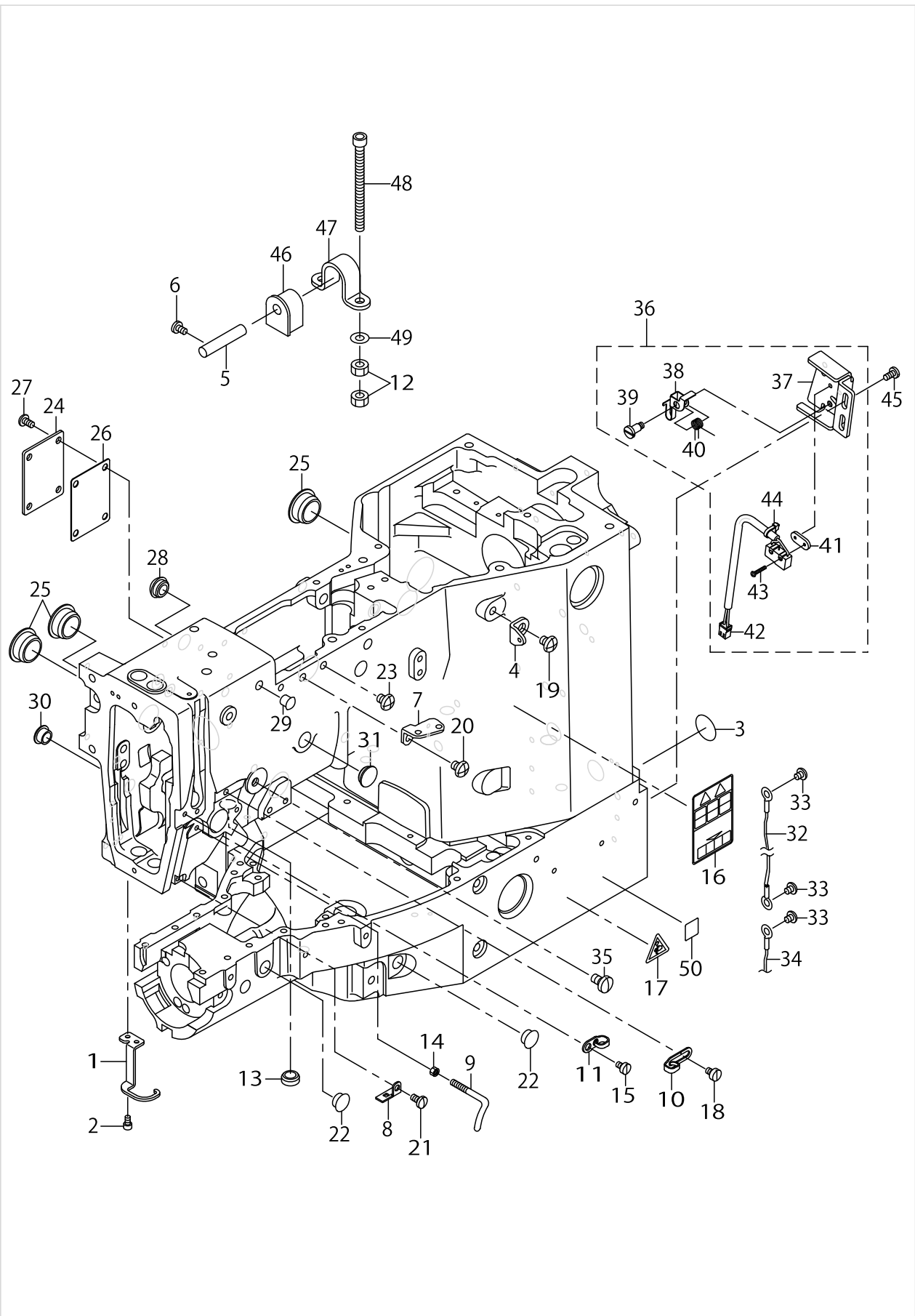

FRAME & MISCELLANEOUS COVER COMPONENTS(2)

No.	Parts No.	Parts name	Remarks	Level	Cons	Qty
1	14201602	FINGER GUARD(1910)	FOR LK-1941			1
2	SS6090612TP	SCREW 9/64-40 L=6	FOR LK-1941			2
3	22901805	GROUND MARK				1
4	40010414	THREAD_GUIDE_NO.1				1
5	40009290	HINGE STUD				2
6	SS7110730SP	SCREW 11/64-40 L=6.5				2
7	26211904	THREAD GUIDE PLATE				1
8	B1129210000	FRAME THREAD GUIDE (B)				1
9	B1125215P00	L-SHAPED THREAD GUIDE				1
10	22920508	ARM THREAD GUIDE A				1
11	13705108	TAKE-UP THREAD GUIDE B				1
12	NM6060001SC	NUT M6				8
13	TA1270502R0	RUBBER PLUG	EXCEPT H TYPE			1
14	11404308	NUT				1
15	SS6110610TP	SCREW 11/64-40 L=6				1
16	CM301200001	SAFETY LABEL_S				1
17	CM300200002	CAUTION LABEL(25)				3
18	SS6110610TP	SCREW 11/64-40 L=6				1
19	SS4150715SP	SCREW 15/64-28 L=7				1
20	SS4150715SP	SCREW 15/64-28 L=7				1
21	SS7110840SP	SCREW 11/64-40 L=7.8				1
22	TA1050504R0	RUBBER PLUG				2
23	SS4150715SP	SCREW 15/64-28 L=7				1
24	B1123210D00	COVER				1
25	TA2100904R0	RUBBER PLUG				3
26	B1125210D00	COVER GASKET				1
27	SS4110815SP	SCREW 11/64-40 L=8				4
28	TA1250406R0	RUBBER PLUG D=12.5 L=4	H TYPE			1
29	TA0750704R0	RUBBER PLUG	H TYPE			2
30	TA1050504R0	RUBBER PLUG	FOR LK-1942			1
31	TA1250406R0	RUBBER PLUG D=12.5 L=4	FOR LK-1942			1
32	14115653	HEAD GROUND CABLE B ASM.				1
33	SS4110515SP	SCREW 11/64-40 L=5				3
34	M90195800A0	EARTH CABLE ASM.				1
35	SS7161040SP	SCREW 1/4-24 L= 9.5	H TYPE			1
36	14442552	SAFETY SWITCH ASM.				1
37	14442503	SAFETY SWITCH BASE		*		1
38	23638109	SAFETY SWITCH ARM		*		1
39	23638307	SAFETY SWITCH ARM SHAFT		*		1
40	23638208	SAFETY SWITCH SPRING		*		1
41	23638406	SAFETY SWITCH NUT		*		1
42	14442651	SAFETY SWITCH CORD ASM.		*		1
43	SM4021201SC	SCREW M2 L=12		*		2
44	EA9500B0100	CABLE BAND		*		1
45	SS7110840SP	SCREW 11/64-40 L=7.8				2
46	B1115210D00	HINGE RUBBER				2
47	B1111210D00	BED HINGE				2



FRAME & MISCELLANEOUS COVER COMPONENTS(2)

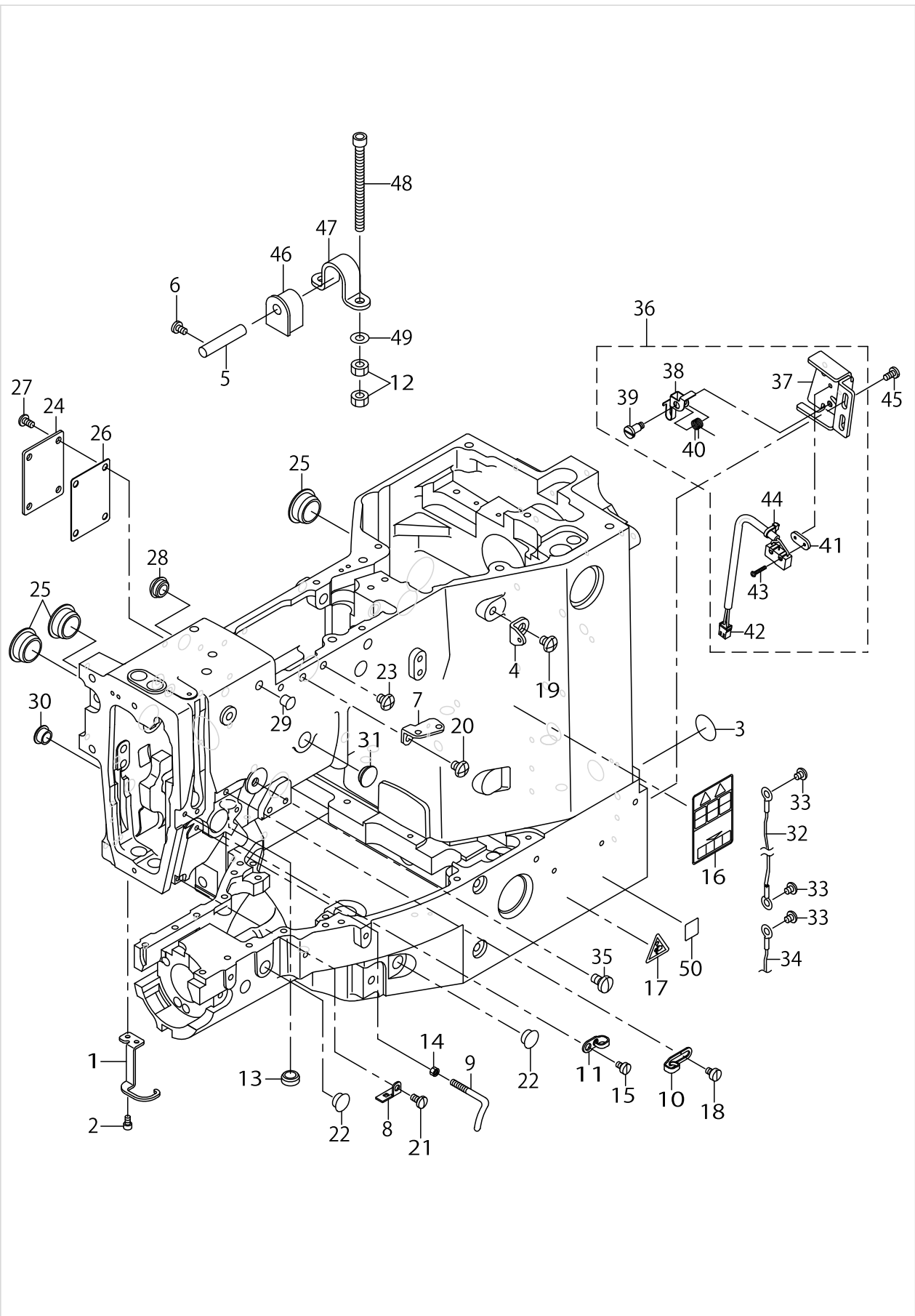

FRAME & MISCELLANEOUS COVER COMPONENTS(2)

No.	Parts No.	Parts name	Remarks	Level	Cons	Qty
48	SM6067552TP	HEXAGONAL-HOLE BOLT M6 L=75				4
49	WP0651646SC	WASHER				4
50	CM600100101	WEEE MARK LABEL S	FOR JE			1

# MAIN SHAFT & NEEDLE BAR COMPONENTS

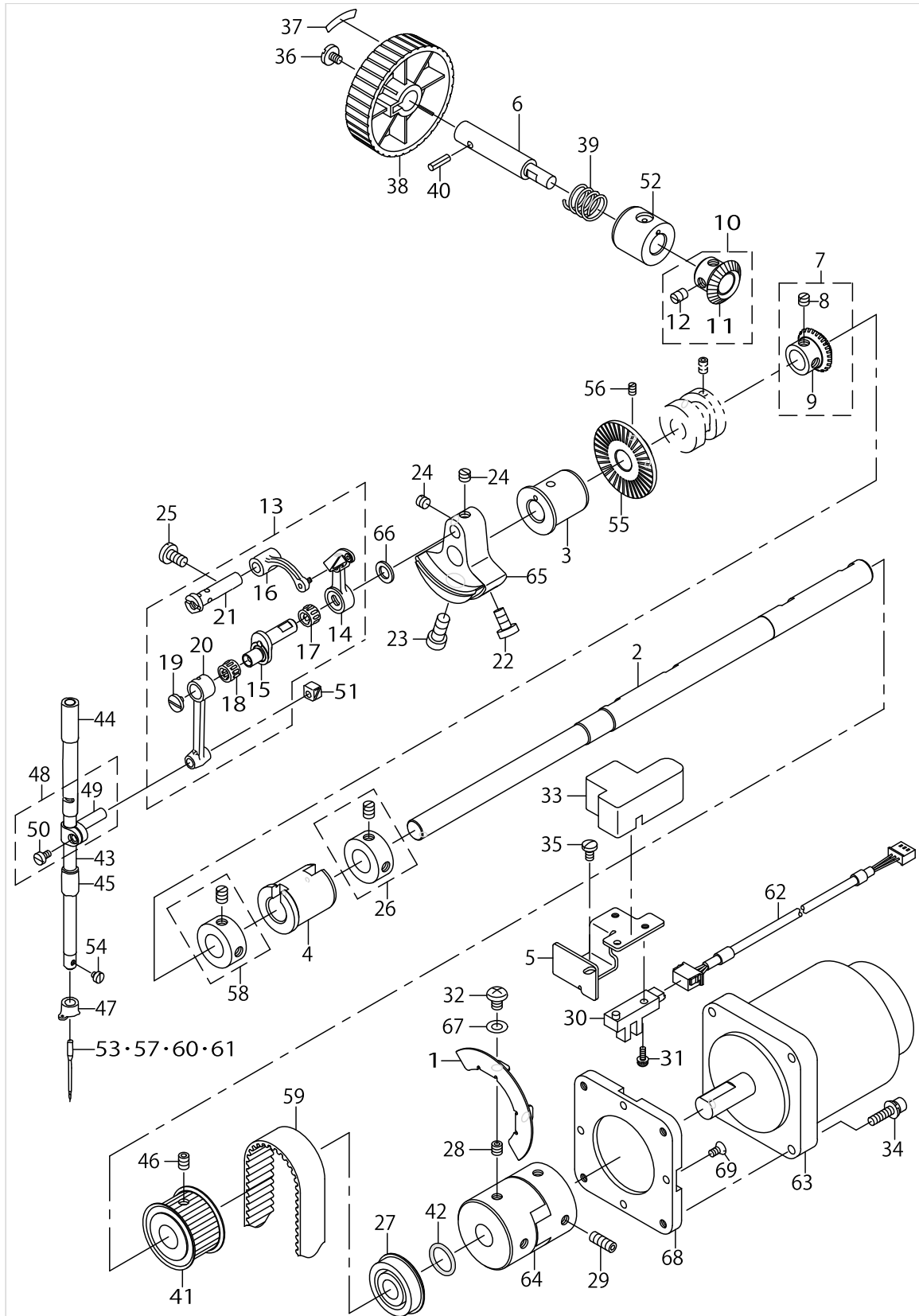

MAIN SHAFT & NEEDLE BAR COMPONENTS

No.	Parts No.	Parts name	Remarks	Level	Cons	Qty
1	14102404	MAIN SHAFT SLIT PLATE				1
2	14431407	MAIN SHAFT				1
3	B1202210000	BUSHING, FRONT				1
4	B1203215000	BUSHING INNER				1
5	14102503	SENSOR INSTALLING BASE				1
6	14431704	NEAR PULLEY SHAFT				1
7	14431852	NEAR PULLEY GEAR A ASM.				1
8	SS8660330SP	SCREW 1/4-40 L=3.0		*		2
9	14431803	HAND PULLEY GEAR A		*		1
10	B13061550A0	PINION ASM.				1
11	B1306155000	PINION		*		1
12	SS8660810TP	SCREW 1/4-40 L=8		*		2
13	14432157	THREAD TAKE-UP LEVER ASM.				1
14	B1901210DA0	THREAD TAKE-UP LEVER COMPL.		*		1
15	14432009	NEEDLE BAR CRANK		*		1
16	B1903210000	THREAD TAKE-UP CRANK		*		1
17	B1905541000	NEEDLE BUSHING		*		1
18	B1411804000	NEEDLE DRIVING LEVER BEARING		*		1
19	B1903552000	LEFT SCREW		*		1
20	B1404280000	NEEDLE BAR CRANK ROD		*		1
21	B1904280000	BALANCE CRANK PIN		*		1
22	SS6151412TP	SCREW 15/64-28 L=14				1
23	SS6681712TP	SCREW 9/32-28 L=16.5				1
24	SS8660512TP	SCREW 1/4-40 L=5				2
25	SS7151120SP	SCREW 15/64-28 L=11				1
26	22904155	MAIN SHAFT THRUST COLLAR ASM.				1
27	G1216870000	UPPER SHAFT REAR BEARING				1
28	SM8060612TP	SCREW M6 L=6				2
29	SM8061612TP	SCREW M6X16				2
30	HD002230000	PHOTO SENSOR				1
31	SL4041291SC	SCREW M4 L=12				1
32	SM4060801SE	SCREW				2
33	14114508	MAIN SHAFT SENSOR COVER				1
34	SL6052092TN	SCREW				4
35	SS7110840SP	SCREW 11/64-40 L=7.8				1
36	A1230500000A	HANDWHEEL SETSCREW				1
37	B1144210000	REVOLVING DIRECTION LABEL				1
38	B1212210D00	PULLEY				1
39	GAF01007000	SPRING				1
40	PS0400142KH	SPRING PIN 4X14				1
41	14404107	DRIVING SPROCKET				1
42	RO154240100	RUBBER RING				1
43	14432702	NEEDLE ROD				1
44	26203208	NEEDLE ROD METAL				1
45	B1403280000	NEEDLE ROD LOWER METAL				1
46	SM8060812TP	SCREW M6 L=8				2
47	B1406210000	THREAD GUIDE				1

MAIN SHAFT & NEEDLE BAR COMPONENTS

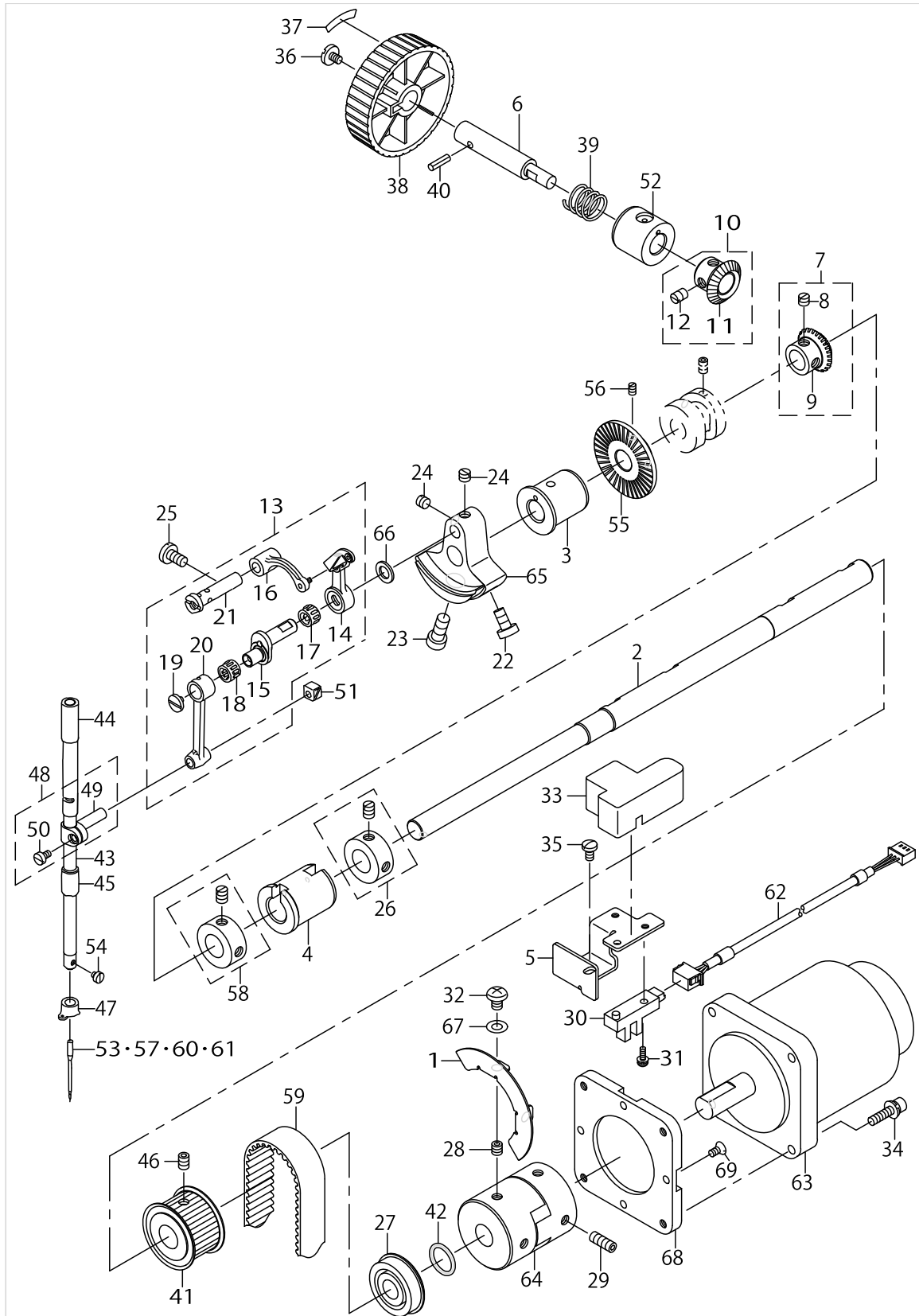

MAIN SHAFT & NEEDLE BAR COMPONENTS

No.	Parts No.	Parts name	Remarks	Level	Cons	Qty
48	22906457	NEEDLE BAR HOLDER ASM.				1
49	22906408	NEEDLE ROD HOLDER		*		1
50	SS6090670TP	SCREW 9/64-40 L=6		*		1
51	B1414232000	SQUARE BLOCK				1
52	26212803	UPPER SHAFT INNER METAL				1
53	MDP170B2500	NEEDLE DPX17 #25	Z TYPE(FOR USE IN JAPAN)			1
54	SS7080510TP	SCREW 1/8-44 L=4.5				1
55	40026917	BTW DRIVING WHEEL				1
56	SM8040600SP	SCREW				2
57	MDP170B1800	NEEDLE DPX17 #18	H TYPE			1
58	CS147121ESH	THRUST COLLAR ASM.D=14.72 W=12				1
59	14431605	TIMING BELT				1
60	MDP170B2300	NEEDLE DPX17 #23	G TYPE			1
61	MDP170B2600	NEEDLE DPX17 #26	Z TYPE(FOR EXPORT)			1
62	14115356	UPPER SHAFT SENSOR CABLE ASM.				1
63	40053326	SERVO MOTOR 550W				1
64	B1231210D00	COUPLING				1
65	14431902	COUNTER WEIGHT				1
66	B1223771000	NEEDLE ROD CRANK WASHER				1
67	WS0610002KN	SPRING WASHER 6.1X12.2X1.5				2
68	40045548	MOTOR INSTALLING BRACKET				1
69	SS1110840SP	SCREW 11/64-40 L=8				4

PRESSER LIFTER COMPONENTS

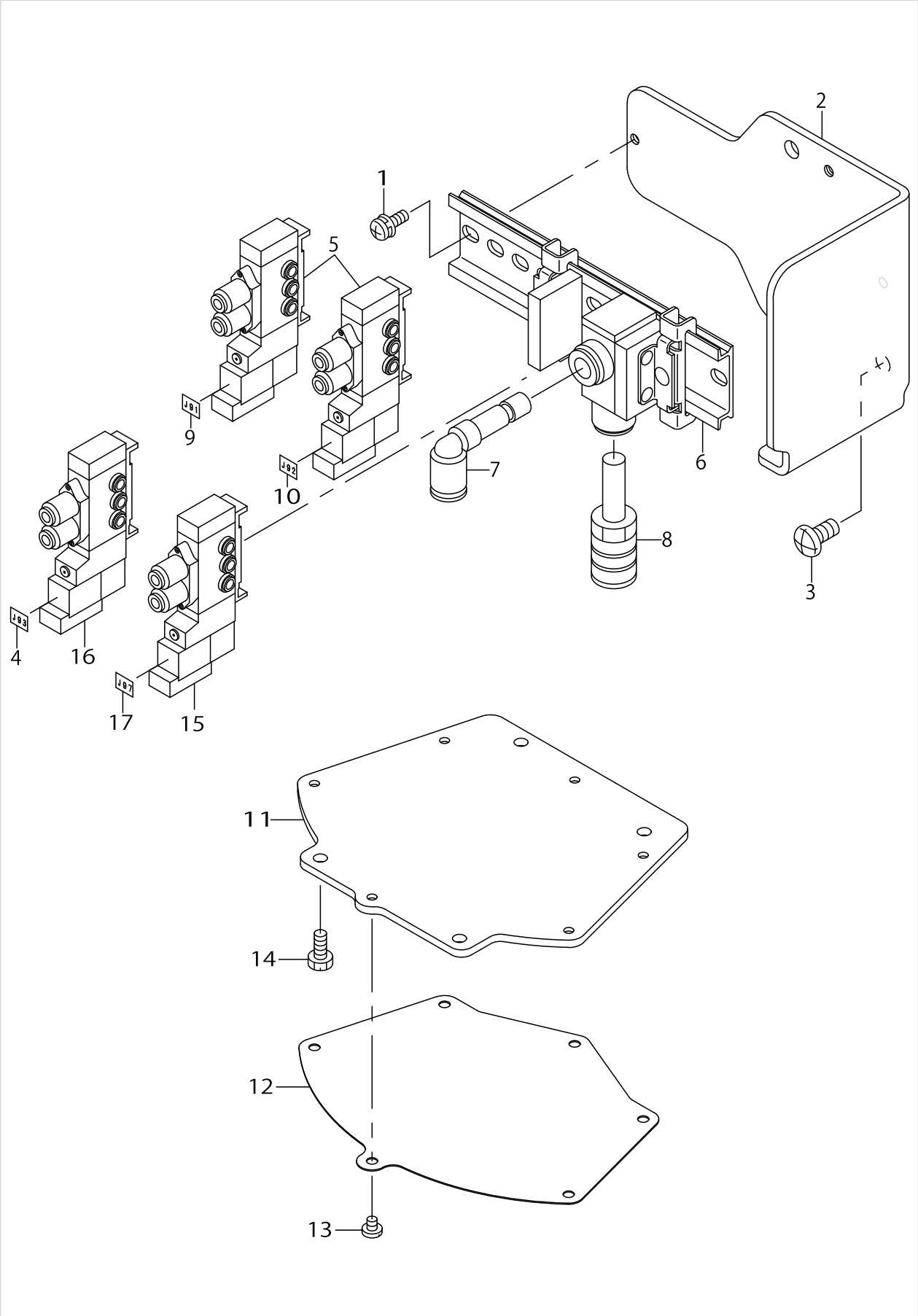

PRESSER LIFTER COMPONENTS

No.	Parts No.	Parts name	Remarks	Level	Cons	Qty
1	SL4041291SC	SCREW M4 L=12				2
2	14204911	FITTING BASE				1
3	SS4151215SP	SCREW 15/64-28 L=12				2
4	E2993453000	CONNECTOR MAKER J93				1
5	PV150209000	5 PORT SOLENOID VALVE				2
6	PV915005000	SOLENOID VALVE INSTALLING BASE				1
7	PJ304060001	ELBOW				1
8	PX050003000	SILENCER				1
9	E2691453000	CONNECTOR MAKER J91				1
10	E2692453000	CONNECTOR MAKER J92				1
11	14203806	PRESSER PLATE(AIR)				1
12	14203905	PRESSER PLATE SHEET				1
13	SS7090410SP	SCREW 9/64-40 L=3.5				6
14	SS9111010SP	SCREW 11/64-40 L=9.5				4
15	PV150209000	5 PORT SOLENOID VALVE				1
16	PV150209000	5 PORT SOLENOID VALVE	FOR LK-1942			1
17	E2697453000	CONNECTOR MAKER J97				1



PRESSER MECHANISM COMPONENTS(FOR LK-1942)

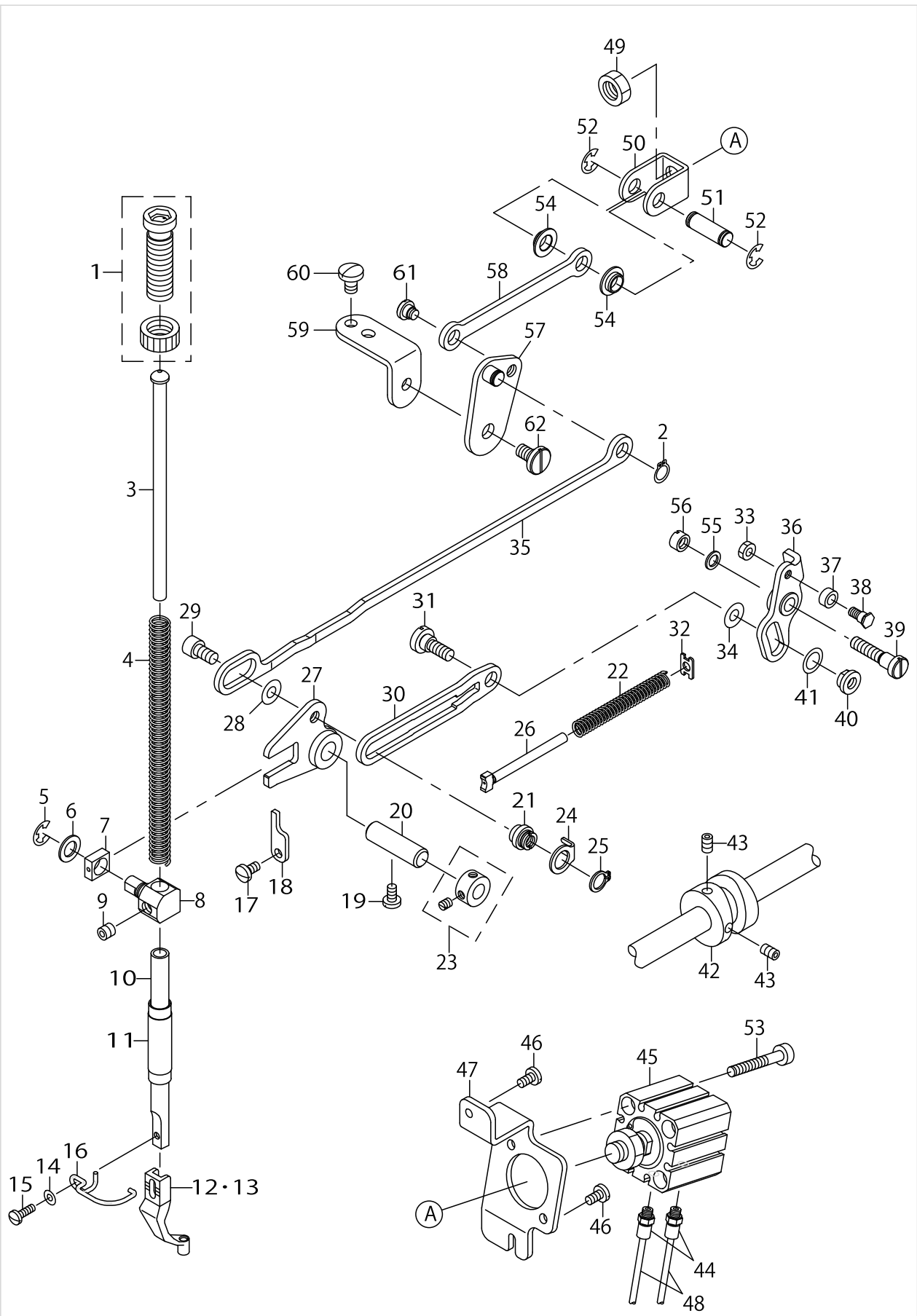

PRESSER MECHANISM COMPONENTS(FOR LK-1942)

No.	Parts No.	Parts name	Remarks	Level	Cons	Qty
1	22907554	PRESSER SPRING REGULATOR ASM.				1
2	RC0740811KP	C-RING				1
3	40023631	PRESSER GUIDE BAR				1
4	14434500	INNER PRESSER SPRING				1
5	RE0600000K0	E-RING 6				1
6	B255728000B	WASHER				1
7	22684906	NEEDLE BAR GUIDE BLOCK				1
8	14434609	INNER PRESSER BAR HOLDER				1
9	SS8660612TP	SCREW 1/4-40 L=6				1
10	26502906	PRESSER BAR				1
11	40014007	PRESSER BAR BUSHING LOWER				1
12	B160122000J	INNER PRESSER J	H TYPE			1
13	14433601	INNER PRESSER K	G TYPE			1
14	WP0371016SD	WASHER 3.7X8X1				1
15	SS7091110TP	SCREW 9/64-40 L=10.5				1
16	B1634210D00	FINGER GUARD				1
17	SS7110840SP	SCREW 11/64-40 L=7.8				1
18	14434708	INNER PRESSER LINK STOPPER				1
19	SS7110810SP	SCREW 11/64-40 L=8.0				1
20	PH1000332SH	PIN 10X33				1
21	14434401	INNER PRESSER ROD PIN				1
22	14434005	INNER PRESSER ROD SPRING				1
23	CS100081CSP	THRUST COLLAR ASM.				1
24	14434203	ROD SPRING HOLDER A				1
25	RC0841011KP	RETAINING RING 8.4				1
26	14434104	ROD SPRING GUIDE BAR				1
27	14433858	INNER PRESSER LINK COMPL.				1
28	WP0600816SP	WASHER				1
29	SS6151142TP	SCREW 15/64-28 L=10.5				1
30	14433908	INNER PRESSER ROD				1
31	SD0800431SP	HINGE SCREW D=8 H=4.3				1
32	14434302	ROD SPRING HOLDER B				1
33	NS6110420SP	NUT 11/64-40				1
34	WP0612066SP	WASHER 6.1X11X2				1
35	40025746	LINK				1
36	14206650	DRIVE ARM COMPL.				1
37	D2587L8WB00	ROLLER				1
38	14209308	INNER PRESSER ROLLER SHAFT				1
39	40031323	HINGE SCREW				1
40	B1633210D00	ADJUSTING NUT				1
41	WP0951016SP	WASHER 9.53X15X1				1
42	14434807	INNER PRESSER CAM				1
43	SM8050812TP	SCREW M5X8				2
44	PJ032052503	HOSE NIPPLE				2
45	PA2501506A0	AIR CYLINDER				1
46	SS7110840SP	SCREW 11/64-40 L=7.8				2
47	40045549	CYLINDER FITTING PLATE				1

PRESSER MECHANISM COMPONENTS(FOR LK-1942)

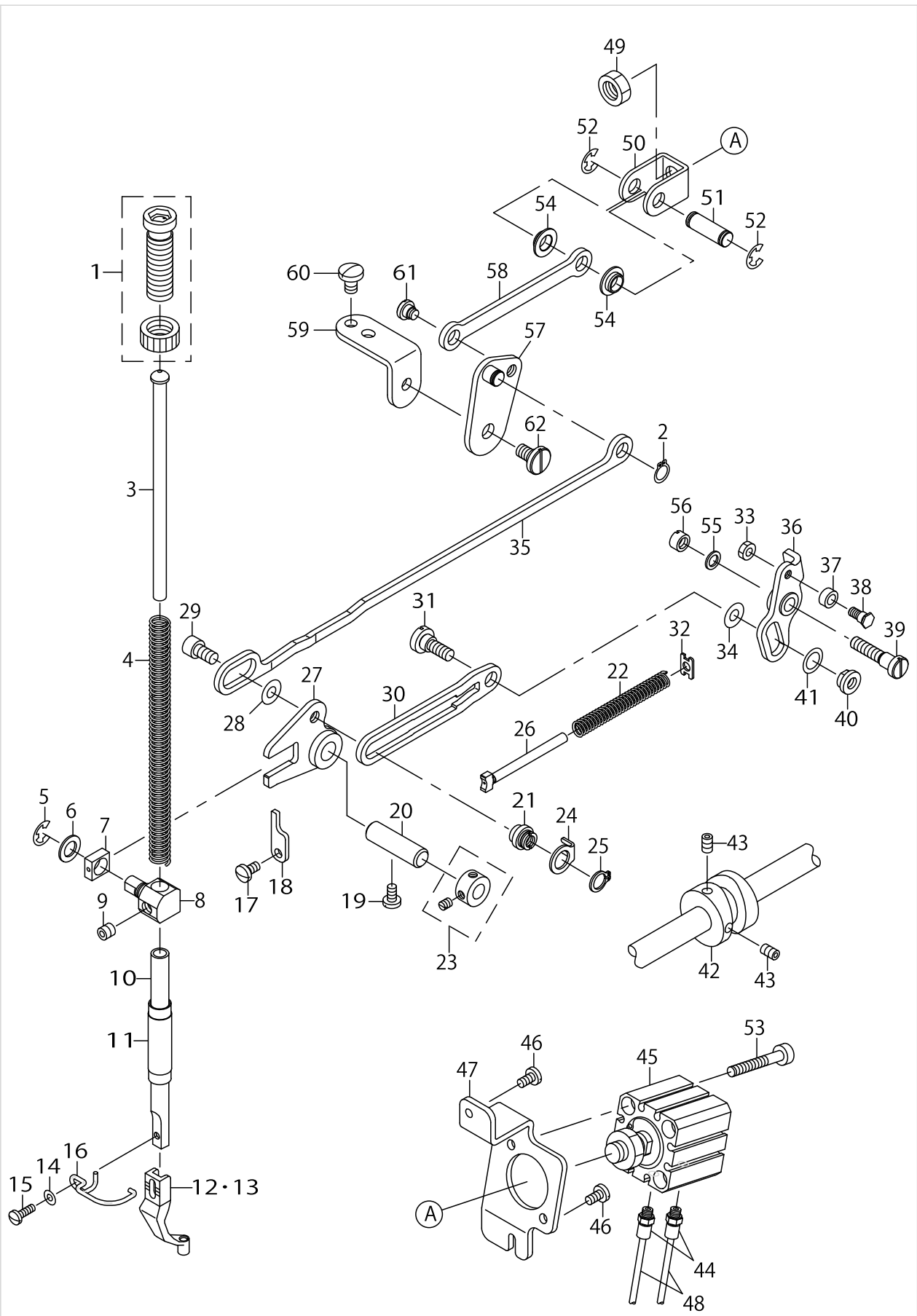

PRESSER MECHANISM COMPONENTS(FOR LK-1942)

No.	Parts No.	Parts name	Remarks	Level	Cons	Qty
48	BT0400251EB	URETHANE HOSE, BLACK				0.3
49	NM6540023SB	NUT				1
50	13860200	CYLINDER PUSHING PLATE				1
51	13860606	PIN				1
52	RE0600000K0	E-RING 6				2
53	SM6053502TP	BOLT				2
54	E1612173000	FLANGE BUSH (0803)				2
55	WP0621026SP	WASHER 6.2X9.5X1				1
56	40031324	NUT				1
57	40045550	CONNECTING LINK COMPL.				1
58	40045552	INNER PRESSER ROD				1
59	40045553	LINK BRACKET				1
60	SS7150910TP	SCREW 15/64-28 L=9				2
61	SD0800341SP	HINGE SCREW D=8 H=3.4				1
62	SD0800321TH	HINGE SCREW D=8 H=3.2				1

SHUTTLE DRIVER SHAFT & HOOK SHAFT COMPONENTS

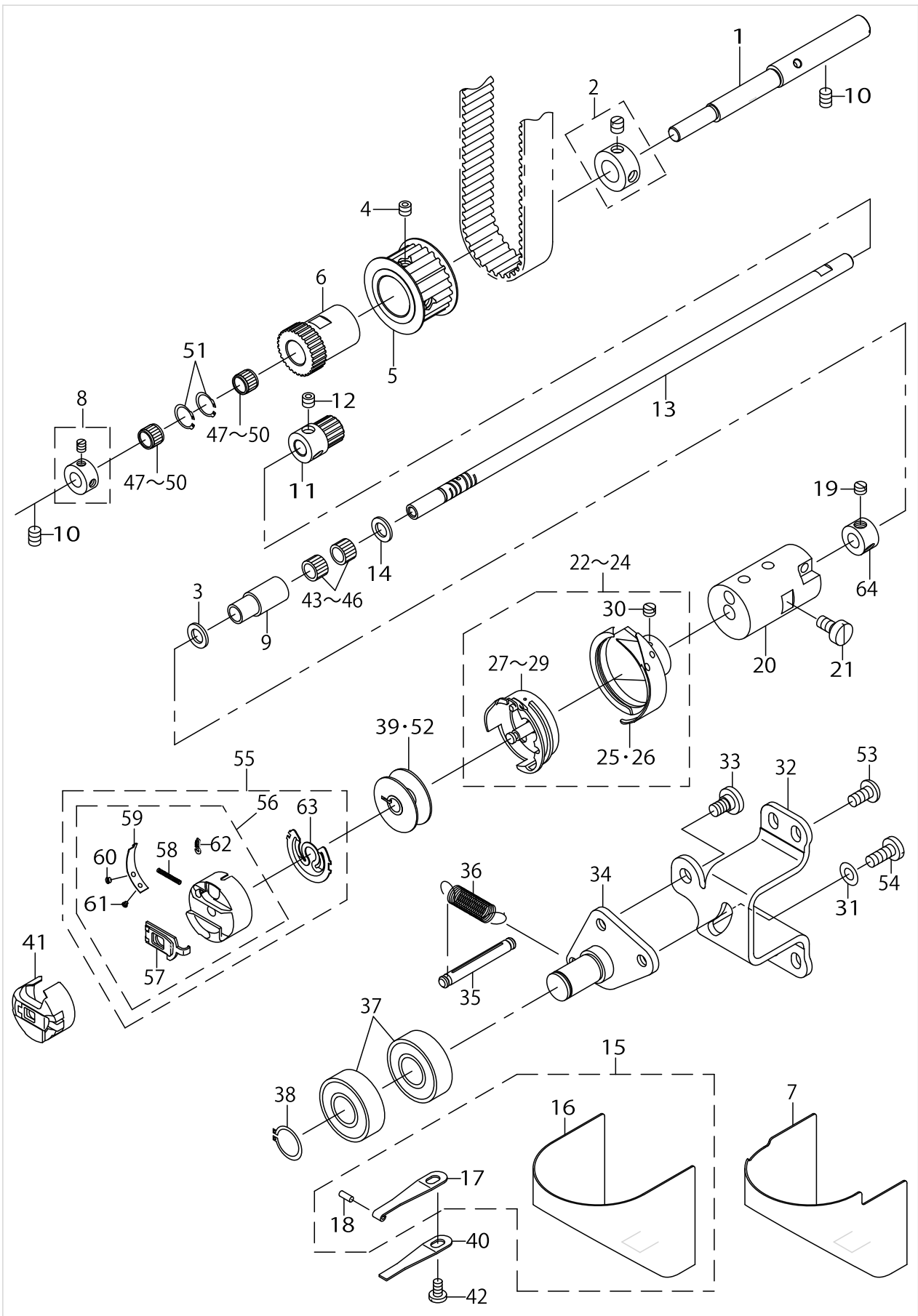

SHUTTLE DRIVER SHAFT & HOOK SHAFT COMPONENTS

No.	Parts No.	Parts name	Remarks	Level	Cons	Qty
1	14435507	SHUTTLE DRIVER SHAFT				1
2	CS1201010SH	THRUST COLLAR ASM. D=12 W=10				1
3	B1223771000	NEEDLE ROD CRANK WASHER				1
4	SS8660522TP	SCREW 1/4-40 L=4.5				2
5	14435606	SHUTTLE DRIVER SHAFT SPROCKET				1
6	14435705	SHUTTLE DRIVER SHAFT GEAR				1
7	14435358	HOOK COVER ASM.	Z TYPE(EXCEPT FOR AW-2D)			1
8	CS100081CSP	THRUST COLLAR ASM.				1
9	13508403	LOWER SHAFT REAR METAL				1
10	SS8150822TP	SCREW 15/64-28 L=8				2
11	14435804	HOOK SHAFT GEAR				1
12	SS8660522TP	SCREW 1/4-40 L=4.5				2
13	14435903	HOOK SHAFT				1
14	B1223771000	NEEDLE ROD CRANK WASHER				1
15	40086483	CYLINDER_ARM_CAP_ASM.				1
16	13816855	CYLINDER ARM CAP		*		1
17	26221101	HOOK COVER PRESSER SPRING A		*		1
18	13508700	HOOK COVER PRESSER SPRING PIN		*		1
19	SS8660410SP	SCREW 1/4-40 L=4.2				2
20	14436000	HOOK SHAFT METAL				1
21	SS6151220SP	SCREW 15/64-28 L=11.5				1
22	14436158	LUBRICATION HOOK D ASM.	Z TYPE			1
23	14436554	LUBRICATION HOOK A ASM.	H TYPE			1
24	14436307	LUBRICATION HOOK C ASM.	G TYPE			1
25	14447106	OUTER HOOK AB	H TYPE	*		1
26	14447205	OUTER HOOK CD	G,Z TYPE	*		1
27	14447304	INNER HOOK A	H TYPE	*		1
28	14447403	INNER HOOK BC	G TYPE	*		1
29	14447502	INNER HOOK D	Z TYPE	*		1
30	SS6110560TP	SCREW 11/64-40 L=5		*		1
31	WP0641601SD	WASHER M6				1
32	14432306	IDLER FITTING PLATE				1
33	SD0800321TH	HINGE SCREW D=8 H=3.2				1
34	14432454	IDLER BASIS COMPL.				1
35	13518501	SPRING SUSPENSION				1
36	14432504	IDLER SPRING				1
37	SB115000200	BEARING				2
38	RC0150001KP	RETAINING RING 13.8				1
39	40022188	BOBBIN ASM	FOR AW-2D			1
40	26221200	HOOK COVER PRESSER SPRING B	EXCEPT FOR AW-2D			1
41	GAW02502AA0	BOBBIN CASE ASM.	FOR AW-2D			1
42	SS7110840SP	SCREW 11/64-40 L=7.8				1
43	B1411804A00	NEEDLE DRIVING LEVER BEARING A	SELECTIVE PARTS			2
44	B1411804B00	NEEDLE DRIVING LEVER BEARING B	SELECTIVE PARTS			1
45	B1411804C00	NEEDLE DRIVING LEVER BEARING C	SELECTIVE PARTS			1
46	B1411804D00	NEEDLE DRIVING LEVER BEARING D	SELECTIVE PARTS			1
47	SB31000080A	BEARING	SELECTIVE PARTS			1

SHUTTLE DRIVER SHAFT & HOOK SHAFT COMPONENTS

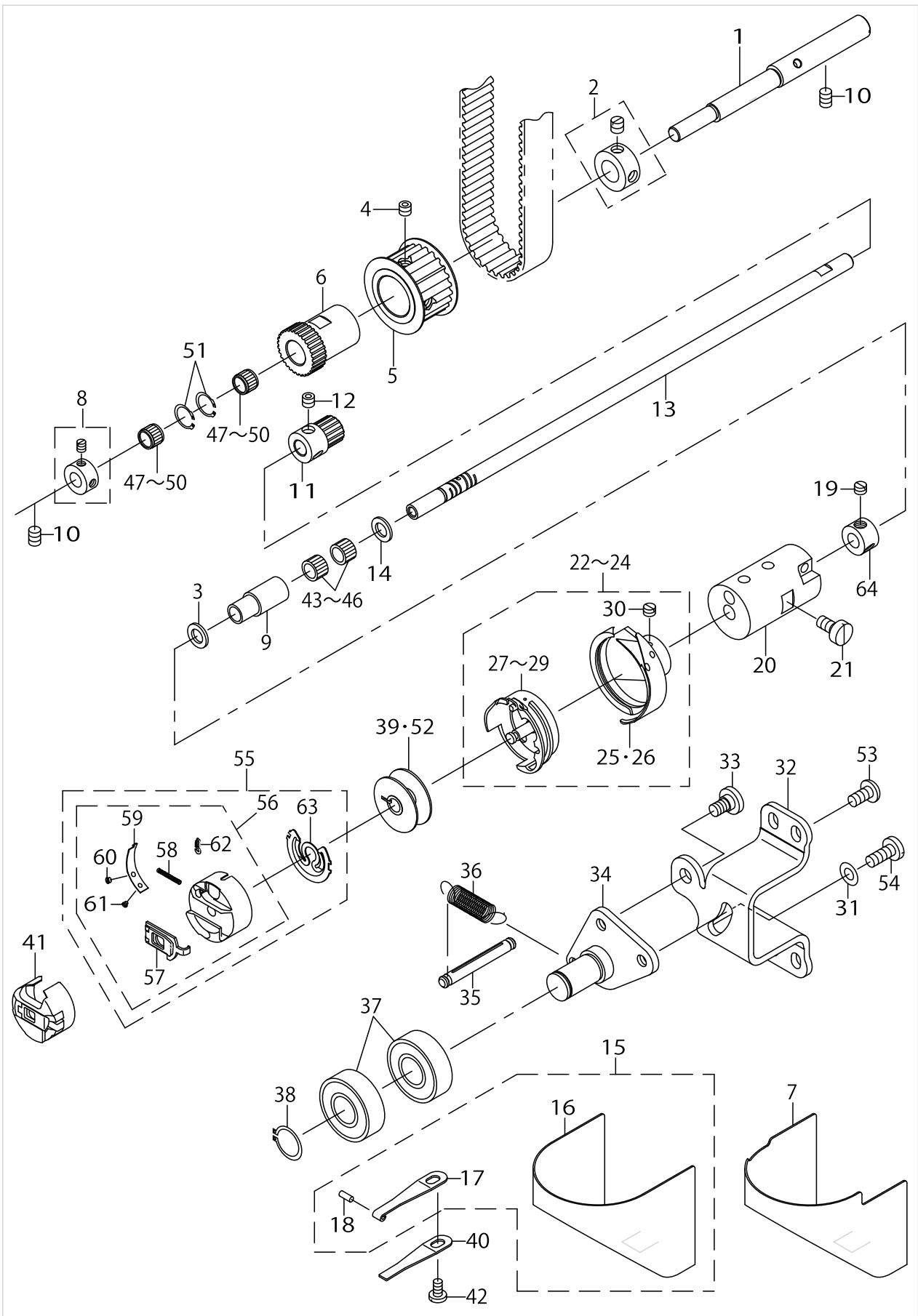

SHUTTLE DRIVER SHAFT & HOOK SHAFT COMPONENTS

No.	Parts No.	Parts name	Remarks	Level	Cons	Qty
48	SB31000080B	BEARING	SELECTIVE PARTS			1
49	SB31000080C	BEARING	SELECTIVE PARTS			1
50	SB31000080D	BEARING	SELECTIVE PARTS			1
51	RC1411018KP	C RING				2
52	14436406	BOBBIN	EXCEPT FOR AW-2D			1
53	SS4151215SP	SCREW 15/64-28 L=12				4
54	SS7661540SP	SCREW 1/4-40 L=15.0				1
55	14436257	BOBBIN CASE ASM.	EXCEPT FOR AW-2D			1
56	14436208	BOBBIN CASE		*		1
57	14446207	PICK-UP ASM.		*		1
58	14446306	PICK-UP SPRING		*		1
59	14446405	THREAD TENSION SPRING		*		1
60	14446504	SCREW		*		1
61	14446603	SCREW		*		1
62	40011360	THREAD GUIDE SPRING		*		1
63	14435200	IDLING PREVENTION SPRING		*		1
64	CS0801011TH	THRUST COLLAR D=8 W=10				1



WIPER MECHANISM COMPONENTS

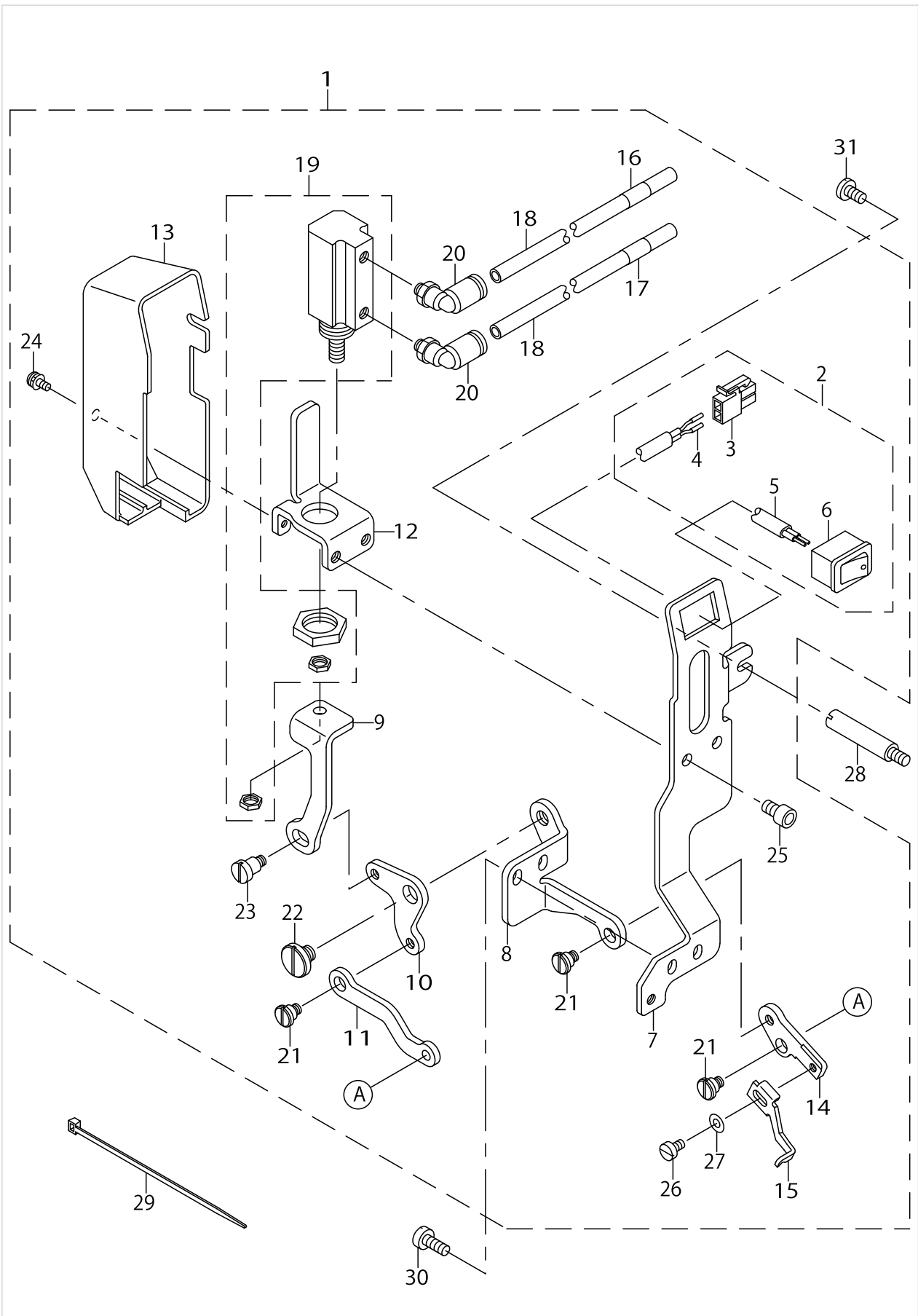

WIPER MECHANISM COMPONENTS

No.	Parts No.	Parts name	Remarks	Level	Cons	Qty
1	14437651	WIPER ASM.				1
2	14437750	WIPER SWITCH CABLE ASM.		*		1
3	HK034610020	2-POLE NYLON PLUG		*		1
4	HK034640000	PIN CONTACT		*		2
5	HW500070000	2-CORE CABTYRE CORD		*		1
6	HA006000000	SWITCH		*		1
7	14437800	WIPER BASE A		*		1
8	14437909	WIPER BASE B		*		1
9	14438006	WIPER LINK A		*		1
10	14438105	WIPER LINK B		*		1
11	14438204	WIPER LINK C		*		1
12	14438303	WIPER CYLINDER FITTING PLATE		*		1
13	11072709	WIPER COVER		*		1
14	B2106220000	WIPER INSTALLING PLATE		*		1
15	B2107210000	WIPER		*		1
16	B471122000E	AIR TUBE LABEL J05		*		1
17	B471122000F	AIR TUBE LABEL J06		*		1
18	BT0400251EB	URETHANE HOSE, BLACK		*		1.5
19	PA1501515A0	AIR CYLINDER		*		1
20	PJ304040504	ELBOW UNION		*		2
21	SD0640321SP	HINGE SCREW D=6.35 H=3.2		*		3
22	SD0800331TH	HINGE SCREW D=8 H=3.25		*		1
23	SD0640602SP	HINGE SCREW D=6.35 H=6.0		*		1
24	SL4030891SC	SCREW M3X8		*		1
25	SM6050802TP	SCREW M5X0.8 L=8		*		2
26	SS6090630TP	SCREW 9/64-40 L=6		*		1
27	WP0371016SD	WASHER 3.7X8X1		*		1
28	22924005	PUMP BODY STRUT				1
29	EA9500B0100	CABLE BAND				1
30	SS6111140SP	SCREW 11/64-40 L=11				2
31	SS7110840SP	SCREW 11/64-40 L=7.8				1

TENSION RELEASE & THREAD TENSION COMPONENTS

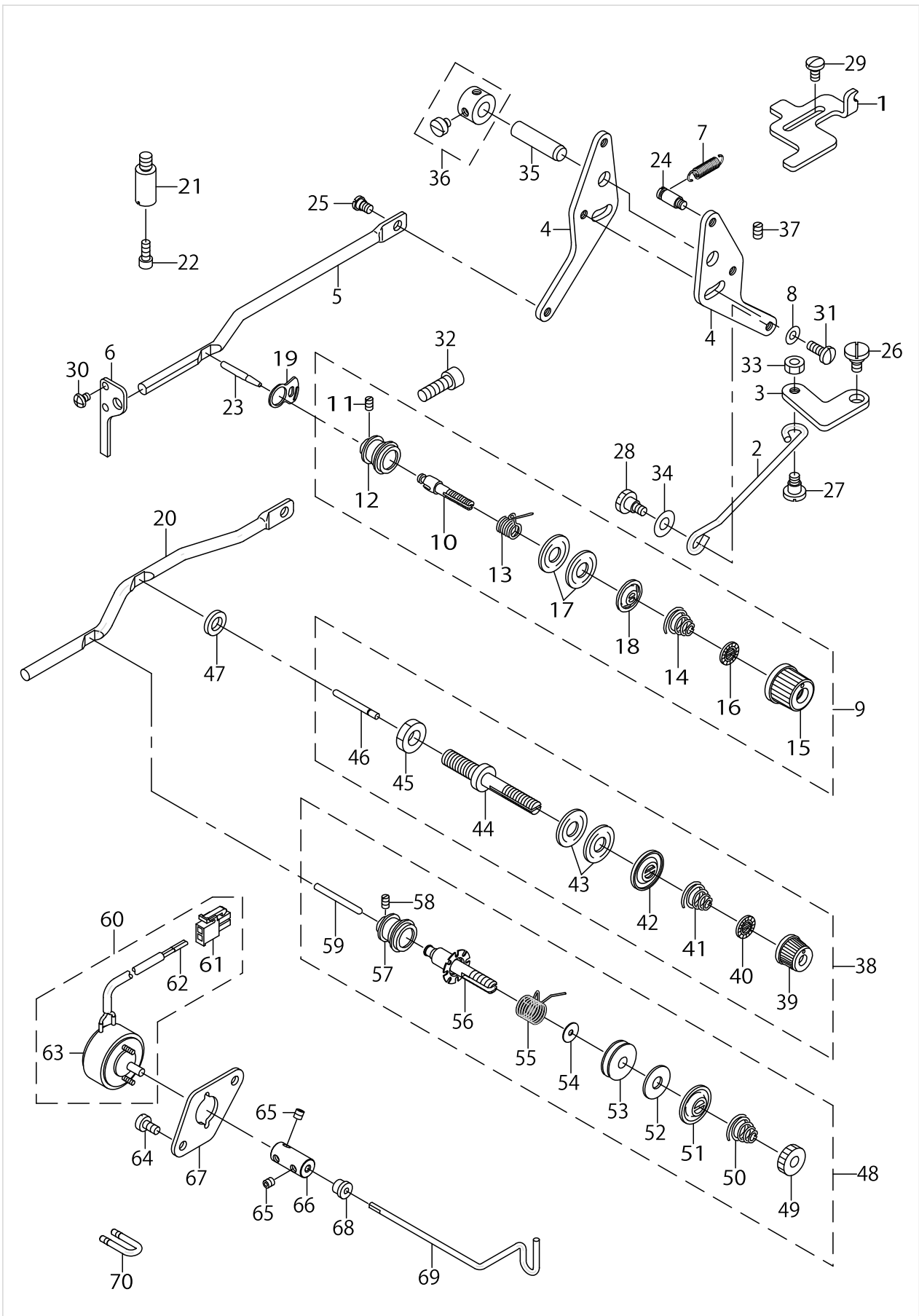

TENSION RELEASE & THREAD TENSION COMPONENTS

No.	Parts No.	Parts name	Remarks	Level	Cons	Qty
1	14107502	STOPPER				1
2	14107700	CONNECTING BAR				1
3	B2304210D00	TENSION RELEASE LINK				1
4	26500900	TENSION RELEASE ADJUSTING ARM				2
5	26501304	THREAD TENSION CONNECTING ROD	H TYPE			1
6	26218404	THREAD TENSION ARM				1
7	B2545280000	PRESSURE SPRING				1
8	WP0482086SD	WASHER 4.8X11.5X2				1
9	B23022050AA	SECOND THREAD TENSION.	H TYPE			1
10	B2302280000	SECOND THREAD TENSION ROD		*		1
11	SS8090610SP	SCREW 9/64-40 L=5.9		*		1
12	B2313280000	THREAD TENSION ROD, LARGE		*		1
13	D3112L4BB00	TAKE-UP SPRING (HEAVY)		*		1
14	B2305205000	TENSION SPRING		*		1
15	13817408	THREAD TENSION NUT		*		1
16	B3120125000	ROTATING STOPPER		*		1
17	B3126012000	THREAD TENSION DISK		*		2
18	B3132552000	THREAD TENSION DISK PRESSER		*		1
19	B2702210000	GUIDE PLATE				1
20	14438709	THREAD TENSION CONNECTING BAR	EXCEPT H TYPE			1
21	13788302	MOUNTING PLATE SHAFT	EXCEPT H TYPE			1
22	SS6111052TP	SCREW	EXCEPT H TYPE			1
23	G2303270000	THREAD RELEASE PIN	H TYPE			1
24	26229302	SUSPENSION SCREW				1
25	SD0530221SP	HINGE SCREW D=5.3 H=2.2				1
26	SD0720321TP	HINGE SCREW				1
27	SD0640391TP	HINGE SCREW D=6.35 H=3.9				1
28	SD0640482SP	HINGE SCREW D=6.35 H=4.8				1
29	SS6110810TP	SCREW 11/64-40 L=8				2
30	SS4090515SP	SCREW 9/64-40 L=5				2
31	SS7111120TP	SCREW				1
32	SS6151812TP	SCREW 15/64-28 L=18				1
33	NS6120310SP	NUT 3/16-28				1
34	WP0651056SD	WASHER 6.5X11X1				1
35	40009290	HINGE STUD				1
36	22917157	THRUST COLLAR ASM., REAR				1
37	SS8110510SP	SCREW 11/64-40 L=5				1
38	14438659	SECOND THREAD TENSION ASM.	EXCEPT H TYPE			1
39	B3119771000	THREAD TENSION NUT		*		1
40	B3120125000	ROTATING STOPPER		*		1
41	B2305205000	TENSION SPRING		*		1
42	B3132012000	TENSION DISC HOLDER		*		1
43	B3126012000	THREAD TENSION DISK		*		2
44	B2019372000	TENSION POST NO.2		*		1
45	NS6160520SP	NUT 1/4-24		*		1
46	D3127555B00	TENSION RELEASE SUPPORTING PIN		*		1
47	WP0722316SH	WASHER	EXCEPT H TYPE			1

TENSION RELEASE & THREAD TENSION COMPONENTS

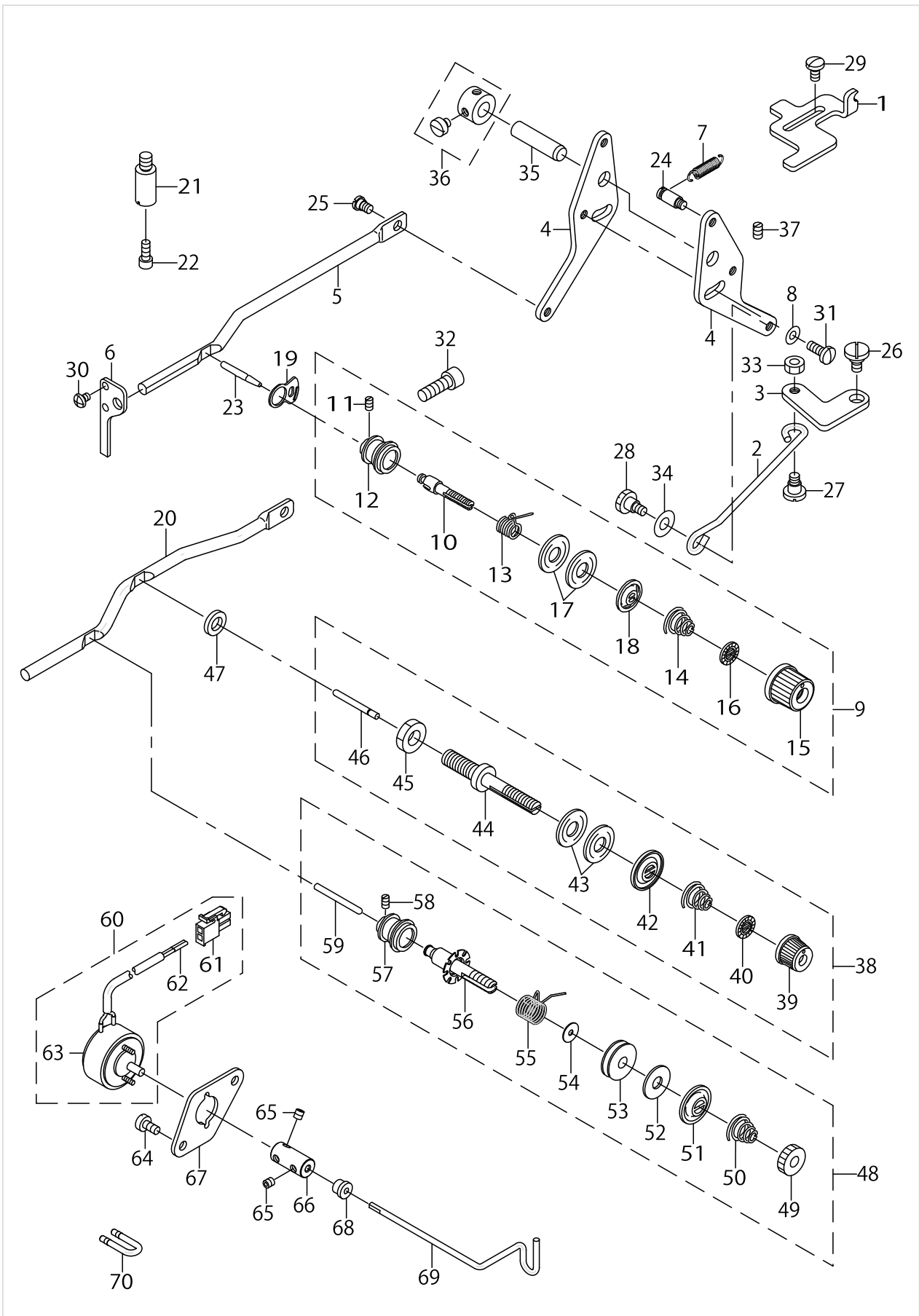

TENSION RELEASE & THREAD TENSION COMPONENTS

No.	Parts No.	Parts name	Remarks	Level	Cons	Qty
48	14438568	AUXILIARY THREAD TENSION ASM.	EXCEPT H TYPE			1
49	B3125012000	THREAD TENSION NUT		*		1
50	B2305205000	TENSION SPRING		*		1
51	10006005	TENSION DISC HOLDER		*		1
52	B3120704000	THREAD TENSION SPRING FELT		*		1
53	21060009	THREAD TENSION WHEEL		*		1
54	22528509	FELT		*		1
55	14438402	THREAD TENSION SPRING		*		1
56	14438550	THREAD TENSION COMPL.		*		1
57	B2313280000	THREAD TENSION ROD, LARGE		*		1
58	SS8090610SP	SCREW 9/64-40 L=5.9		*		1
59	14442305	THREAD RELEASE PIN		*		1
60	14432959	DRAW OUT SOLENOID ASM.	EXCEPT H TYPE			1
61	HK034610020	2-POLE NYLON PLUG		*		1
62	HK03464000A	TERMINAL, FEMALE		*		2
63	10570307	DISK RISING SOLENOID		*		1
64	SS6110810TP	SCREW 11/64-40 L=8	EXCEPT H TYPE			2
65	SM8040412TP	SET SCREW M4 L=4	EXCEPT H TYPE			3
66	14433205	DRAW OUT LEVER COUPLING	EXCEPT H TYPE			1
67	14433007	SOLENOID FITTING PLATE	EXCEPT H TYPE			1
68	B3319704L00	THREAD GUIDE	EXCEPT H TYPE			1
69	14433106	DRAW OUT LEVER	EXCEPT H TYPE			1
70	B2014372000A	THREAD GUIDE	EXCEPT H TYPE			1

TENSION RELEASE & THREAD TRIMMER MECHANISM COMPONENTS(1)

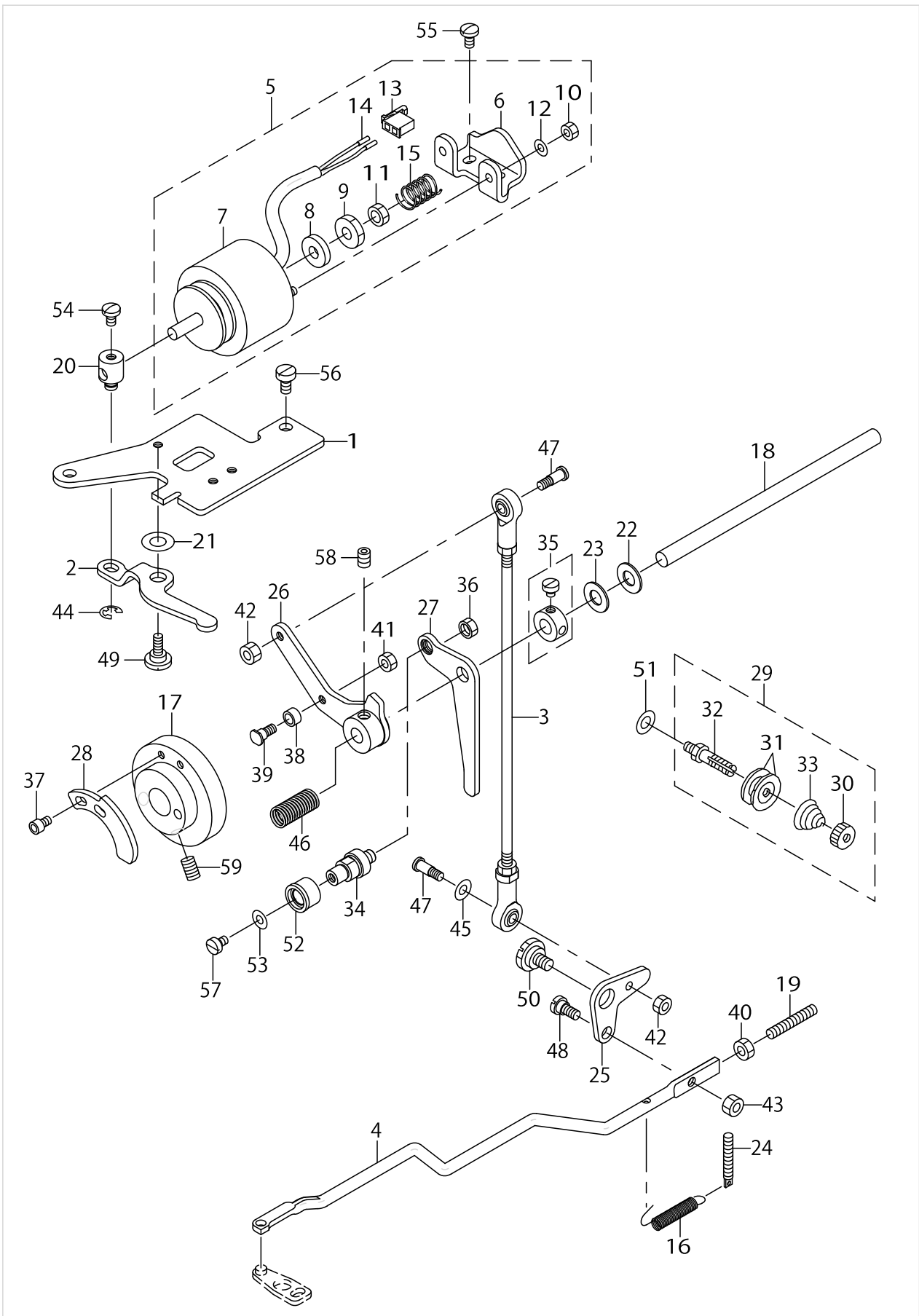

TENSION RELEASE & THREAD TRIMMER MECHANISM COMPONENTS(1)

No.	Parts No.	Parts name	Remarks	Level	Cons	Qty
1	26501205	CAM FOLLOWER STOPPER				1
2	14108500	SOLENOID ARM				1
3	14108609	CONNECTING ROD				1
4	26501908	CONNECTING BAR				1
5	14108955	THREAD TRIMMING SOLENOID ASM.				1
6	14108807	SOLENOID INSTALLING BASE		*		1
7	14108906	SOLENOID FOR THREAD TRIMMING		*		1
8	11043304	SOLENOID RUBBER		*		1
9	NS6660410SH	NUT		*		1
10	NM6040000SN	NUT M4		*		2
11	NS6660430SP	NUT 1/4-40		*		1
12	WP0450000SD	WASHER 4.5X8X0.5		*		2
13	HK03461002D	HOUSING		*		1
14	HK034640000	PIN CONTACT		*		2
15	B1652704000	SPRING		*		1
16	14109300	THREAD TRIM LINK SPRING				1
17	B2401210D00	THREAD TRIMMER CAM				1
18	B2408210D00	THREAD TRIMMER SHAFT				1
19	SM8053002TP	SCREW M5 L=30				1
20	22951008	SOLENOID PIN				1
21	WP0553216SD	WASHER				1
22	B1223771000	NEEDLE ROD CRANK WASHER				1
23	B1116804000	CLOTH PLATE WASHER				1
24	26226506	SPRING HOOK				1
25	B2411210000	THREAD TRIMMER LINK				1
26	14109250	CAM FOLLOWER ASM.				1
27	14438907	THREAD RELEASE ARM				1
28	14442404	THREAD RELEASE NOTCH				1
29	26218651	FIRST THREAD TENSION ASM.				1
30	22928808	NUT		*		1
31	22921506	THREAD TENSION DISK		*		2
32	26220400	THREAD TENSION ROD		*		1
33	26218602	FIRST THREAD TENSION SPRING		*		1
34	14439004	ROLLER SHAFT				1
35	CS080081BSH	THRUST COLLAR ASM. D=8.0 W=8				1
36	NS6660430SP	NUT 1/4-40				1
37	SM6040602TP	SCREW M4 L=6				2
38	D2587L8WB00	ROLLER				1
39	D2588L8WB00	ROLLER SHAFT				1
40	NM6050001SP	NUT M5				1
41	NS6110420SP	NUT 11/64-40				1
42	NS6110420SP	NUT 11/64-40				2
43	NS6120310SP	NUT 3/16-28				1
44	RE0500000K0	E-RING				1
45	WP0501016SD	WASHER 5X10.5X1				1
46	B2617771000	TRIPPING LEVER TENSION SPRING				1
47	SD0500803TP	HINGE SCREW D=5 H=8				2



TENSION RELEASE & THREAD TRIMMER MECHANISM COMPONENTS(1)

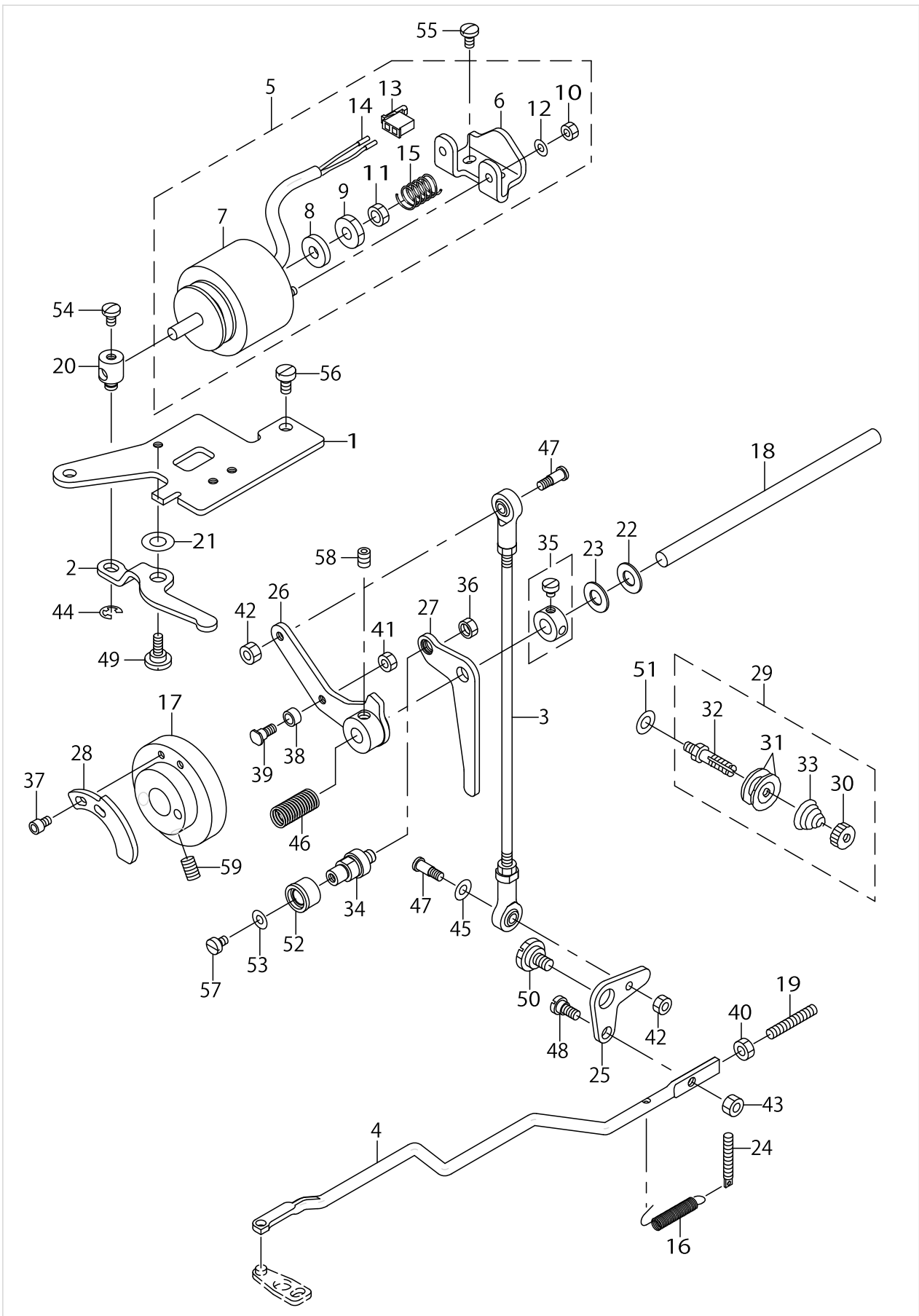

## TENSION RELEASE &amp; THREAD TRIMMER MECHANISM COMPONENTS(1)

No.	Parts No.	Parts name	Remarks	Level	Cons	Qty
48	SD0650305TP	HINGE SCREW D=6.5 H=3				1
49	SD0790311TP	HINGE SCREW D=7.94 H=3.1				1
50	SD1100301TP	HINGE SCREW H=11 W=3				1
51	WP0641600SC	WASHEW 6.4X12.5X1.6	EXCEPT H TYPE			1
52	14438808	THREAD RELEASE ARM ROLLER				1
53	WP0451026SH	WASHER				1
54	SS7110740TP	SCREW 11/64-40 L=7				1
55	SS7110840SP	SCREW 11/64-40 L=7.8				2
56	SS6120930SP	SCREW 3/16-28 L=9				2
57	SS6110610TP	SCREW 11/64-40 L=6				1
58	SS8150822TP	SCREW 15/64-28 L=8				1
59	SS8661012TP	SCREW				2



TENSION RELEASE & THREAD TRIMMER MECHANISM COMPONENTS(2)

No.	Parts No.	Parts name	Remarks	Level	Cons	Qty
1	14439152	H TYPE NEEDLE PLATE ASM.	H TYPE			1
2	14439251	G TYPE NEEDLE PLATE ASM.	G TYPE			1
3	14439608	NEEDLE HOLE GUIDE D=3	H TYPE	*		1
4	14439707	NEEDLE HOLE GUIDE D=4	G TYPE	*		1
5	SS1060210TP	SCREW 3/32-56 L=2.2		*		2
6	B2417280000	THREAD CUTTER LEVER SHAFT		*		1
7	14439103	NEEDLE PLATE		*		1
8	B242328000A	MOVING KNIFE WASHER A	SELECTIVE PARTS	*		1
9	B242328000B	MOVING KNIFE WASHER B	SELECTIVE PARTS	*		1
10	B242328000C	MOVING KNIFE WASHER C	SELECTIVE PARTS	*		1
11	B242328000D	MOVING KNIFE WASHER D	SELECTIVE PARTS	*		1
12	B242328000E	MOVING KNIFE WASHER E	SELECTIVE PARTS	*		1
13	B2417210000	MOVING KNIFE HINGE SCREW		*		1
14	14440309	MOVING KNIFE	EXCEPT Z TYPE	*		1
15	14441000	FIXING KNIFE	H TYPE	*		1
16	SS7090410SP	SCREW 9/64-40 L=3.5	EXCEPT Z TYPE	*		2
17	14440457	MOVING KNIFE LINK COMPL.		*		1
18	SS7110740TP	SCREW 11/64-40 L=7		*		1
19	WP0450846SP	WASHER		*		1
20	SS6110430TP	SCREW 11/64-40 L=4.0		*		1
21	B24142800A0	THREAD CUTTER LEVER ASM., LARGE		*		1
22	14440556	THREAD LEVER TYPE COMPL.		*		1
23	B2416280000	THREAD CUTTING LEVER RING		*		1
24	14441109	FIXING KNIFE G	G TYPE	*		1
25	14436604	INNER HOOK STOPPER				1
26	WP0450846SP	WASHER				2
27	SS7110710SP	SCREW 11/64-40 L=7				2
28	40023523	HOT WIRE NEEDLE ASM	Z TYPE			1
29	14440002	ELLIPSE NEEDLE HOLE GUIDE	Z TYPE	*		1
30	SS1060210TP	SCREW 3/32-56 L=2.2		*		1
31	B2417210000	MOVING KNIFE HINGE SCREW		*		1
32	14439103	NEEDLE PLATE		*		1
33	40039621	INSULATING SHEET B	Z TYPE	*		1
34	40022223	HOT WIRE PLATE	Z TYPE	*		1
35	SL4040681SC	COMBINATION SCREW M4X8	Z TYPE	*		4
36	14441208	MOVING KNIFE	Z TYPE	*		1
37	40022013	HOT WIRE BASE ASM	Z TYPE	*		1
38	WP0371016SD	WASHER 3.7X8X1	Z TYPE	*		2
39	SS4091015SP	SCREW 9/64-40 L=10	Z TYPE	*		2
40	14440457	MOVING KNIFE LINK COMPL.		*		1
41	WP0450846SP	WASHER		*		1
42	SS7110740TP	SCREW 11/64-40 L=7		*		1
43	SS6110430TP	SCREW 11/64-40 L=4.0		*		1
44	B24142800A0	THREAD CUTTER LEVER ASM., LARGE		*		1
45	14440556	LEVER TYPE COMPL.		*		1
46	B2416280000	THREAD CUTTING LEVER RING		*		1
47	B2417280000	THREAD CUTTER LEVER SHAFT		*		1

TENSION RELEASE & THREAD TRIMMER MECHANISM COMPONENTS(2)

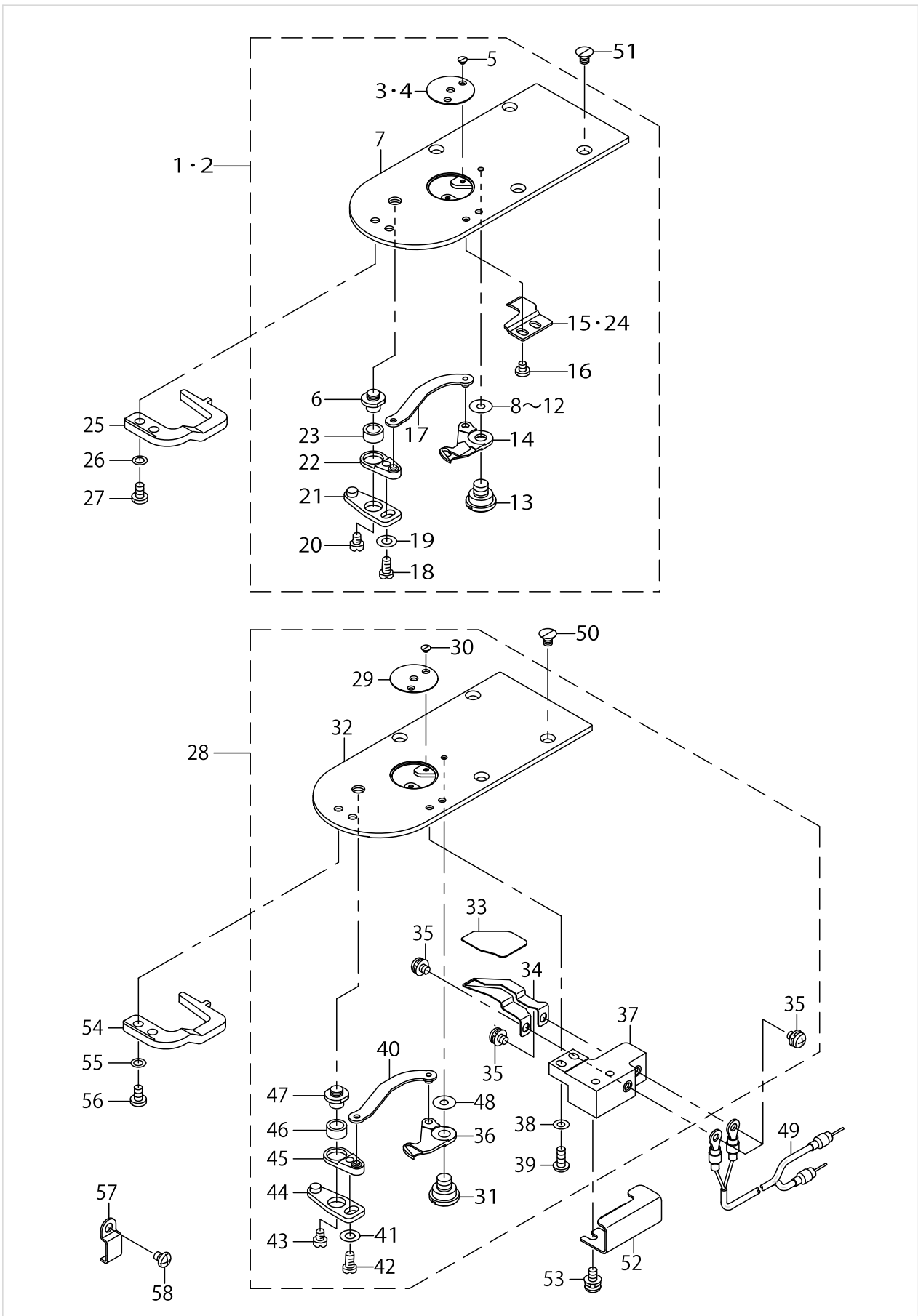

## TENSION RELEASE &amp; THREAD TRIMMER MECHANISM COMPONENTS(2)

No.	Parts No.	Parts name	Remarks	Level	Cons	Qty
48	B242328000B	MOVING KNIFE WASHER B		*		1
49	14442255	HEATER CORD ASM.	Z TYPE			1
50	SS1110640TP	SCREW 11/64-40 L=5.5				4
51	SS1110640TP	SCREW 11/64-40 L=5.5				4
52	14441901	HOT WIRE BASE COVER	Z TYPE			1
53	SL4041091SC	SCREW M4 L=10	Z TYPE			2
54	14436604	INNER HOOK STOPPER				1
55	WP0450846SP	WASHER				2
56	SS7110710SP	SCREW 11/64-40 L=7				2
57	B3509210000	OIL TUBE HOLDER C	Z TYPE			3
58	SS4110515SP	SCREW 11/64-40 L=5	Z TYPE			3

FEED MECHANISM COMPONENTS

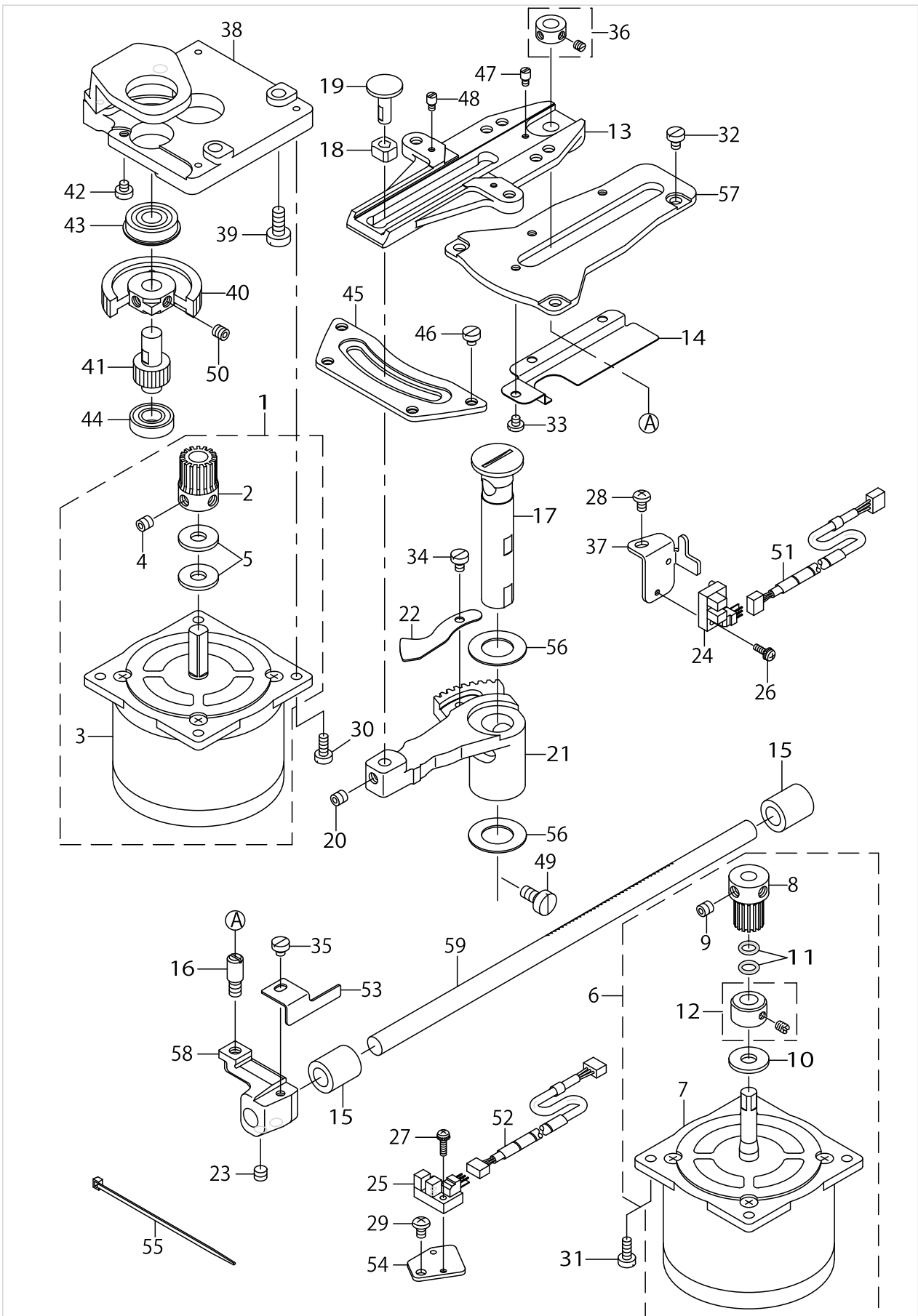

FEED MECHANISM COMPONENTS

No.	Parts No.	Parts name	Remarks	Level	Cons	Qty
1	14216352	X FEED MOTOR ASM.				1
2	26501403	X FEED GEAR		*		1
3	14216303	CROSSFEED STEPPING MOTOR		*		1
4	SM8060812TP	SCREW M6 L=8		*		2
5	14112502	RUBBER WASHER		*		2
6	14449250	Y FEED MOTOR ASM.				1
7	14216410	LENGTHWISE STEPPING MOTOR		*		1
8	26501502	Y FEED GEAR		*		1
9	SM8060812TP	SCREW M6 L=8		*		2
10	14112502	RUBBER WASHER		*		1
11	RO069180100	RUBBER RING		*		2
12	CS095081ASH	THRUST COLLAR ASM. D=9.53 W=8		*		1
13	14214019	CLOTH FEED PLATE				1
14	14215701	CLOTH FEED SUPPORT PLATE COVER				1
15	B2509704000	BUSHING, REAR				2
16	B1456057000	HINGE SCREW				1
17	14447908	CROSSFEED FULCRUM SHAFT				1
18	B1414232000	SQUARE BLOCK				1
19	26223305	SLIDE BLOCK STUD				1
20	SM8060612TP	SCREW M6 L=6				1
21	14448005	CROSSFEED ARM				1
22	14214712	CROSSFEED SENSOR UNIT				1
23	SS8660612TP	SCREW 1/4-40 L=6				2
24	HD00057000A	PHOTO SENSOR				1
25	HD00057000A	PHOTO SENSOR				1
26	SL4031081SC	SCREW M3 X 10				1
27	SL4031291SC	SCREW M3X12				1
28	SS4110715SP	SCREW 11/64-40 L=7				1
29	SS4110715SP	SCREW 11/64-40 L=7				1
30	SS6111140SP	SCREW 11/64-40 L=11				4
31	SS6111140SP	SCREW 11/64-40 L=11				4
32	SS6110610TP	SCREW 11/64-40 L=6				3
33	SS7110410SP	SCREW 11/64-40 L=4				3
34	SS6110610TP	SCREW 11/64-40 L=6				1
35	SS6110480SP	SCREW 11/64-40 L=4.3				1
36	CS079073BSH	THRUST COLLAR				1
37	14214902	CROSSFEED SENSOR FITTING BASE				1
38	14215057	MOTOR BASE COMPL.				1
39	SS6151440SP	SCREW 15/64-28 L=14				3
40	14215404	CROSSFEED GEAR (LARGE)				1
41	14215305	CROSSFEED GEAR (SMALL)				1
42	SS6110480SP	SCREW 11/64-40 L=4.3				1
43	SB110001300	BEARING				1
44	SB110000900	BEARING				1
45	14214308	CROSSFEED SLIDE PLATE				1
46	SS6110420TP	SCREW 11/64-40 L=4.8				4
47	B151902600G	HINGE STUD				1



FEED MECHANISM COMPONENTS

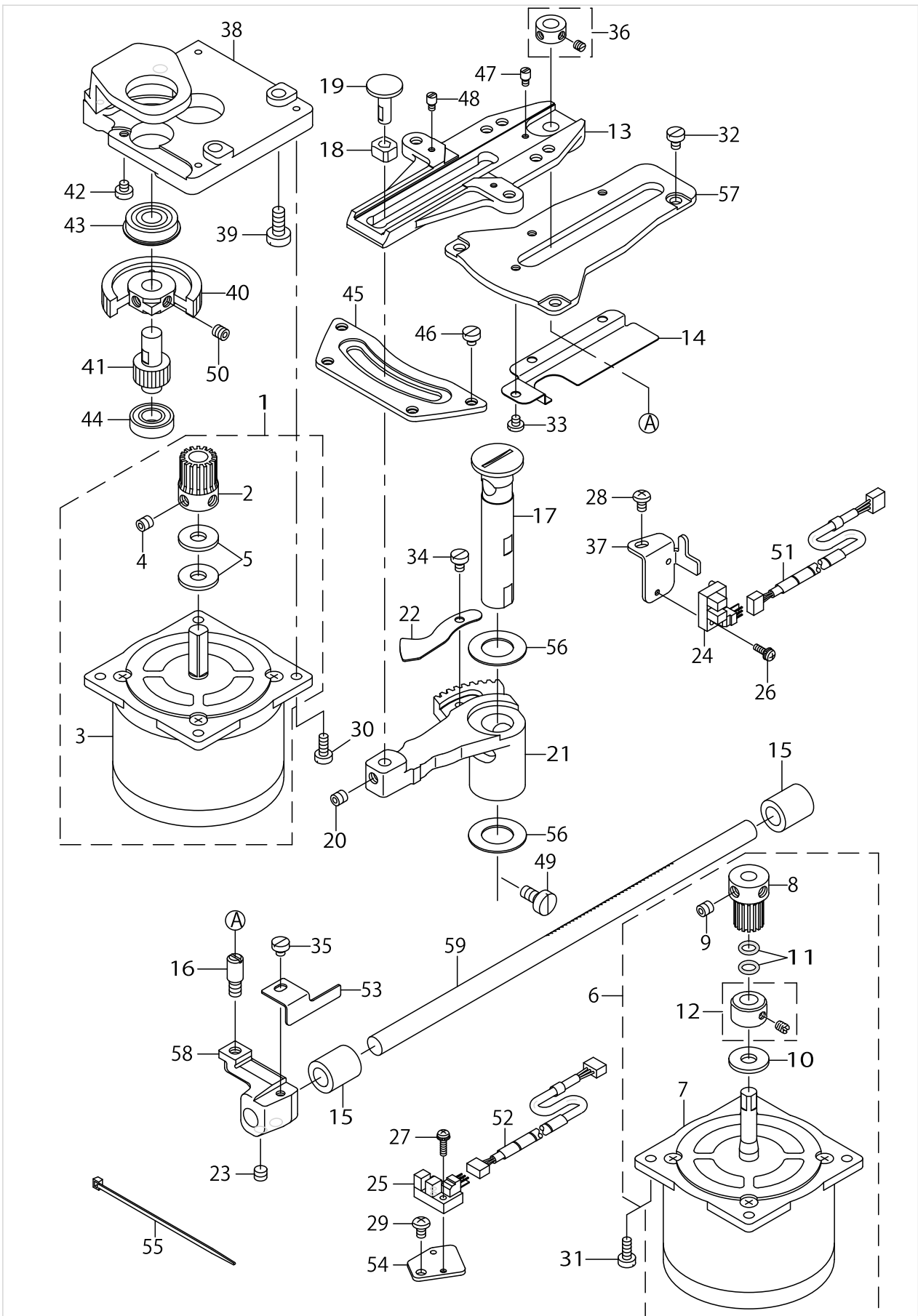

FEED MECHANISM COMPONENTS

No.	Parts No.	Parts name	Remarks	Level	Cons	Qty
48	B151902600G	HINGE STUD				2
49	SS6151220SP	SCREW 15/64-28 L=11.5				2
50	SM8060612TP	SCREW M6 L=6				2
51	14221253	X SENSOR CABLE ASM.				1
52	14221352	Y SENSOR CABLE ASM.				1
53	14216006	LENGTHWISE SENSOR SLIT				1
54	40028986	SENSOR INSTALLING BASE				1
55	EA9500B0200	CABLE BAND 150				2
56	G5523880000	THRUST WASHER B				2
57	14215602	CLOTH FEED SUPPORT PLATE				1
58	14215909	LENGTHWISE FEED ARM				1
59	14216204	LENGTHWISE FEED SHAFT				1

CLOTH FEED MECHANISM COMPONENTS

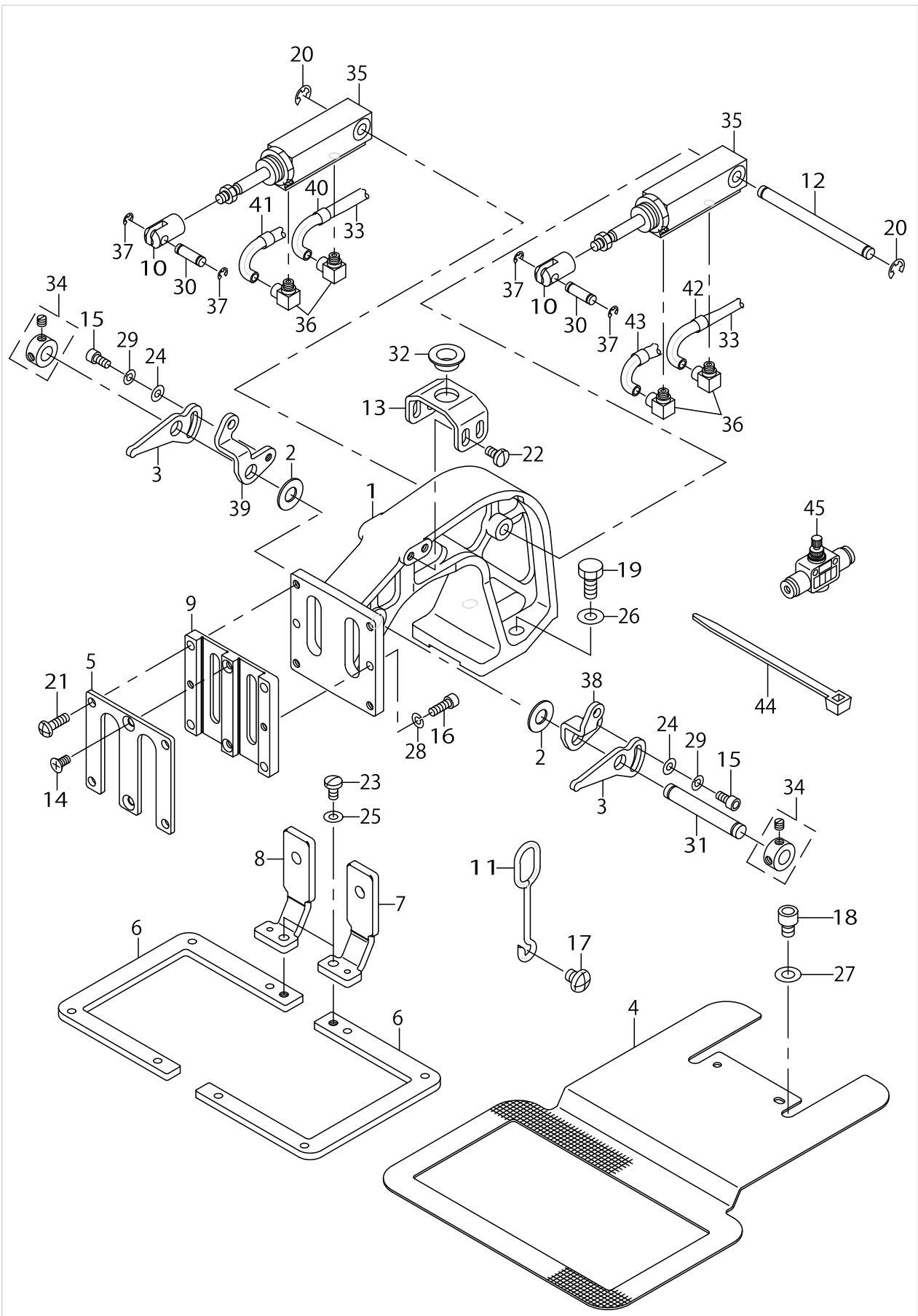

CLOTH FEED MECHANISM COMPONENTS

No.	Parts No.	Parts name	Remarks	Level	Cons	Qty
1	14436802	CLOTH FEED BASE				1
2	B255728000C	WASHER				2
3	14217202	HOOK A				2
4	14218002	LOWER PLATE				1
5	B2572210D00	WORK CLAMP FOOT PLATE COVER				1
6	B2554210D00	FEEDING FRAME				2
7	14437057	SLIDING PLATE RIGHT COMPL.				1
8	14437156	SLIDING PLATE LEFT COMPL.				1
9	B2610210D00	WORK CLAMP FOOT PLATE				1
10	B2566210D00	CYLINDER KNUCKLE				2
11	B3403761000	PRESSER BAR LIFTING ROD				1
12	B2561210D00	CYLINDER SHAFT				1
13	14436901	SLIDER BASE				1
14	SM1040801SP	SCREW M4X0.7 L=8				2
15	SM6040802TP	SCREW M4X0.7 L=8				2
16	SM6041202TP	SCREW M4X0.7 L=12				2
17	SS4150715SP	SCREW 15/64-28 L=7				1
18	SM6060802TP	SCREW M6 L=8				2
19	SM9061403CP	SCREW M6 L=14				2
20	RE0500000K0	E-RING				2
21	SS4111415SP	SCREW 11/64-40 L=14				4
22	SS7110840SP	SCREW 11/64-40 L=7.8				4
23	SS7110840SP	SCREW 11/64-40 L=7.8				2
24	WP0450000SD	WASHER 4.5X8X0.5				2
25	WP0480856SP	WASHER 4.8X8.4X0.8				2
26	WP0621016SD	WASHER 6.2X13X1				2
27	WP0621016SD	WASHER 6.2X13X1				2
28	WS0410002KP	SPRING WASHER				2
29	WS0410002KP	SPRING WASHER				2
30	B1626220000	CYLINDER PIN				2
31	D2502232D00	SHAFT BLOCK SHAFT				1
32	E2193172000	PT EV PP METAL				1
33	BT0400251EB	URETHANE HOSE, BLACK				2.6
34	22917058	THRUST COLLAR ASM., FRONT				2
35	PA1602006A0	AIR CYLINDER				2
36	PJ046052503	HOSE ELBOW				4
37	RE0300000K0	E-RING 3				4
38	14217301	HOOK B,RIGHT				1
39	14217400	HOOK B,LEFT				1
40	B471122000D	AIR TUBE LABEL J04 LEFT				1
41	B471122000C	AIR TUBE LABEL J03 LEFT				1
42	B471122000H	AIR TUBE LABEL J04 RIGHT				1
43	B471122000G	AIR TUBE LABEL J03 RIGHT				1
44	EA9500B0100	CABLE BAND				3
45	PC012401000	SPEED CONTROLLER				2

LUBRICATION COMPONENTS

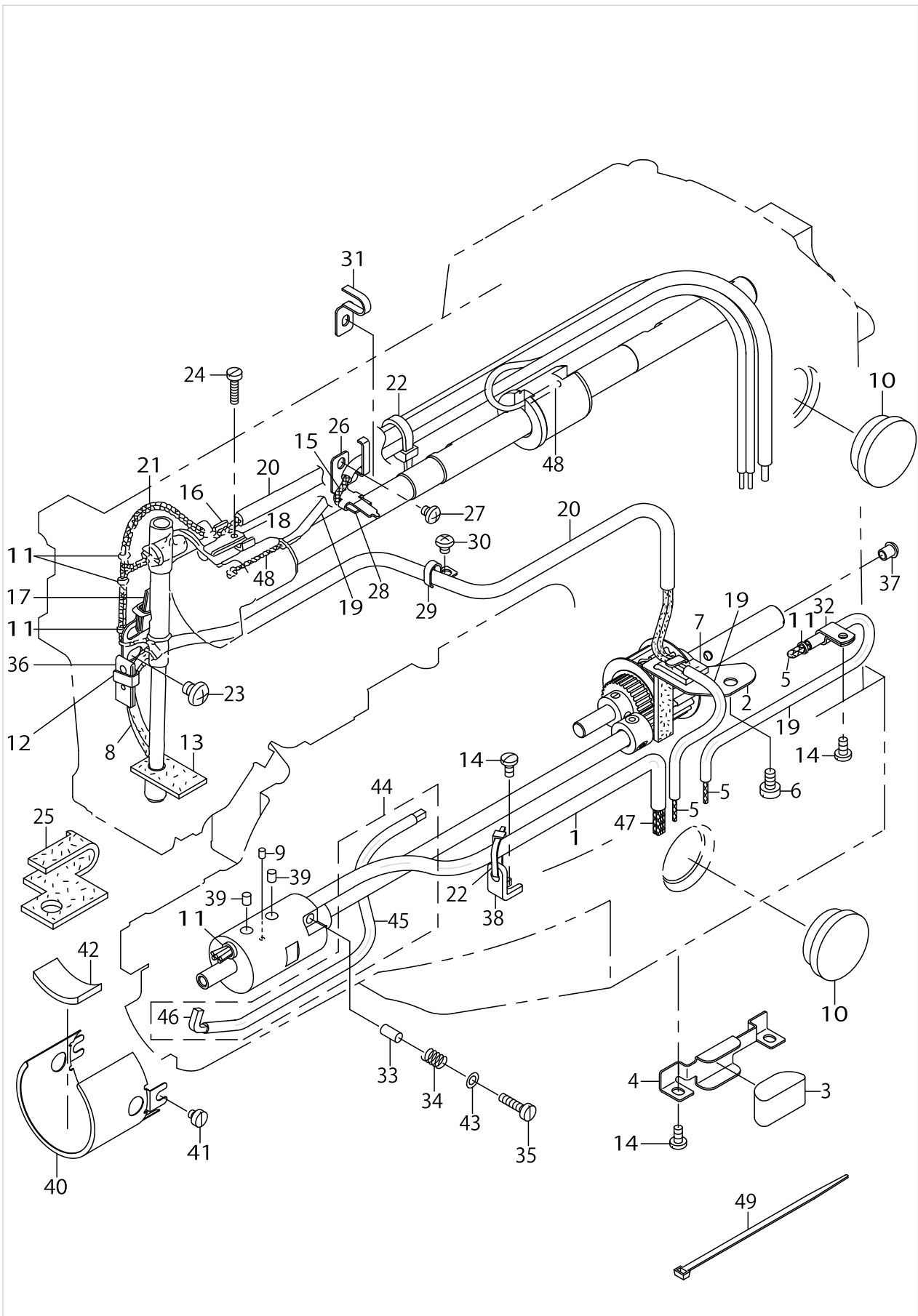

LUBRICATION COMPONENTS

No.	Parts No.	Parts name	Remarks	Level	Cons	Qty
1	BT0700500EA	TUBE				0.3
2	14443204	GEAR LUBRICATING PLATE				1
3	14114300	OIL FELT				1
4	14114409	FELT PRESSER				1
5	CQ202000000	OIL WICK				0.45
6	SS6120930SP	SCREW 3/16-28 L=9				1
7	14443303	GEAR LUBRICATING FELT				1
8	B3541012000	OIL WICK				0.47
9	B1821210D00	SHUTTLE OIL FELT,B				1
10	B3501210000	OIL GAUGE				2
11	26230706	OIL WICK PRESSER				5
12	14219513	LUBRICATION PLATE				1
13	14114607	FACE FELT	FOR LK-1941			1
14	SS7110840SP	SCREW 11/64-40 L=7.8				4
15	CQ200000000	OIL WICK	FOR LK-1942			0.4
16	26231407	BALANCE LUBRICATING PLATE				1
17	B3509220000	OIL SPONGE				1
18	B3518280000	BALANCE LUBRICATING				1
19	23630007	TUBE				1.07
20	BP600000000	VINYL PIPE				0.67
21	CQ252200000	OIL WICK				1.6
22	EA9500B0100	CABLE BAND				2
23	SS4150715SP	SCREW 15/64-28 L=7				2
24	SS6092120SP	SCREW 9/64-40 L=21.2				1
25	14219604	OIL FELT	FOR LK-1942			1
26	14219711	LUBRICATION PLATE	FOR LK-1942			1
27	SS4110515SP	SCREW 11/64-40 L=5				1
28	B3518280000	BALANCE LUBRICATING	FOR LK-1942			1
29	26231902	OIL WICK PIPE STOPPER				1
30	SS4110515SP	SCREW 11/64-40 L=5				1
31	B3523980000	OIL WICK PIPE STOPPER	FOR LK-1941			1
32	HX00150000A	CABLE CLAMP				1
33	12219705	PIN				1
34	B2626372000	SPRING				1
35	SS6111610SP	SCREW 11/64-40 L=16				1
36	B3518280000	BALANCE LUBRICATING	FOR LK-1942			1
37	TA0550604R0	RUBBER PLUG				1
38	B1113223C00	COVER SUPPORTER				1
39	B1820210D00	SHUTTLE OIL FELT,A				2
40	14443402	HOOK OIL PREVENTION PLATE				1
41	SS6110480SP	SCREW 11/64-40 L=4.3				2
42	10126704	OIL FELT				1
43	WP0450000SD	WASHER 4.5X8X0.5				1
44	13530357	SHUTTLE ONCE THROUGH OIL FELT				1
45	13530308	SHUTTLE ONCE THROUGH FELT		*		1
46	BP500000000	VINYL PIPE		*		18
47	CQ200000000	OIL WICK				2.8

LUBRICATION COMPONENTS

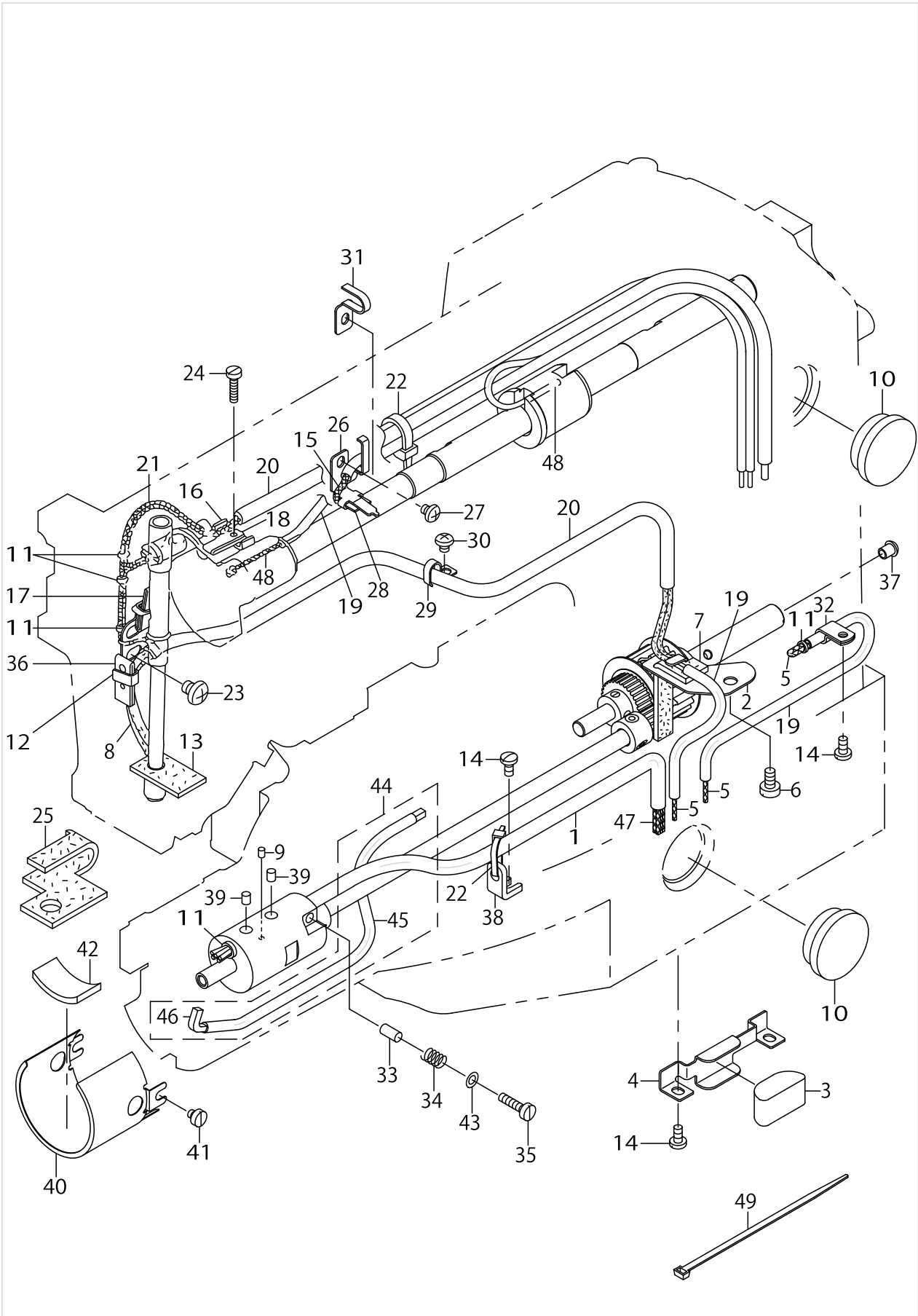

LUBRICATION COMPONENTS

No.	Parts No.	Parts name	Remarks	Level	Cons	Qty
48	CQ252000000	OIL WICK				1.2
49	EA9500B0200	CABLE BAND 150				1



THREAD STAND COMPONENTS (EXCEPT FOR AW-2D)

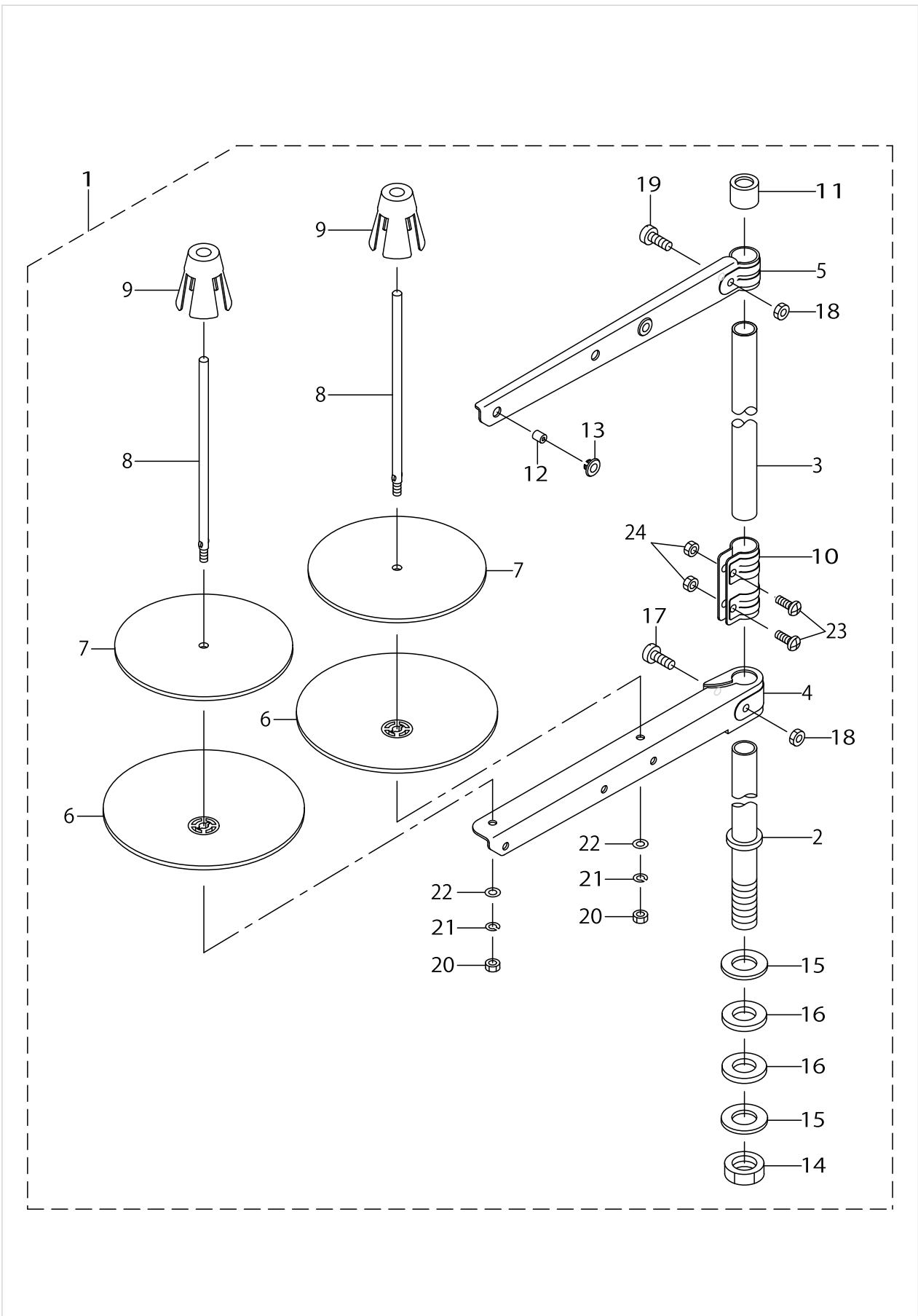

THREAD STAND COMPONENTS (EXCEPT FOR AW-2D)

No.	Parts No.	Parts name	Remarks	Level	Cons	Qty
1	40096354	THREAD STAND ASM.				1
2	40085784	SPOOL REST ROD LOWER		*		1
3	40085785	SPOOL REST ROD UPPER		*		1
4	40085786	SPOOL REST ARM LOWER		*		1
5	40085787	SPOOL REST ARM UPPER		*		1
6	40085788	SPOOL REST		*		2
7	40085789	SPOOL REST CUSHION		*		2
8	40085790	SPOOL PIN		*		2
9	40085791	SPOOL RETAINER		*		2
10	40085792	SPOOL REST ROD JOINT		*		1
11	40085793	SPOOL REST ROD RUBBER CAP		*		1
12	40085794	THREAD GUIDE		*		2
13	40085795	THREAD GUIDE BUSHING		*		2
14	40096325	SPOOL REST ROD NUT		*		1
15	WP1612616SE	WASHER 16X30X2.6		*		2
16	40085796	SPOOL REST ROD RUBBER CUSHION		*		2
17	40096326	SPOOL REST ARM LOWER SCREW		*		1
18	NM6050001SE	NUT M5		*		2
19	40096327	SPOOL REST ARM UPPER SCREW		*		1
20	NM6050001SE	NUT M5		*		2
21	WS0510002KN	SPRING WASHER M5		*		2
22	WP0531001SC	WASHER M5		*		2
23	SM4051405SE	SCREW M5 L=14		*		2
24	NM6050001SE	NUT M5		*		2

# CONTROL BOX COMPONENTS

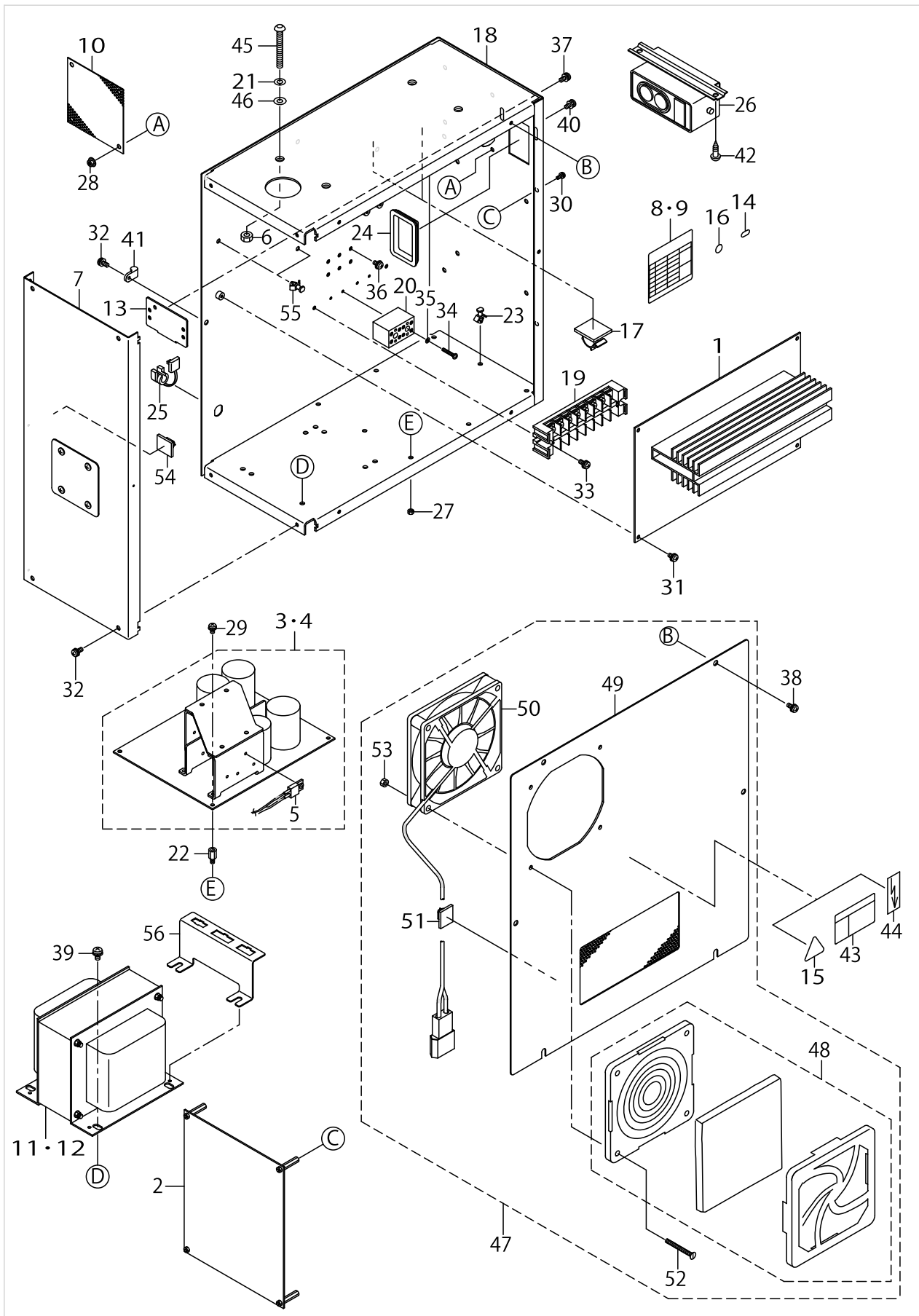

CONTROL BOX COMPONENTS

No.	Parts No.	Parts name	Remarks	Level	Cons	Qty
1	M8601594AA0	MAIN CIRCUIT BOARD A ASM.				1
2	40150001	SDC PCB ASSY				1
3	M86045900C0	POWER CIRCUIT BOARD ASM.	FOR 200V			1
4	M8604590AC0	POWER CIRCUIT BOARD A ASM.	FOR 380V			1
5	M89105900A0	THERMOSTAT ASM.		*		1
6	NM6060001SC	NUT M6				4
7	M10035940A0	CONTROL BOX PANEL ASM.				1
8	M300359000A	SEAL A	FOR 200V			1
9	M300258000B	SEAL B	FOR 380V			1
10	M1004581000	VENTILATION COVER				1
11	M8901594AA0	TRANSFORMER A ASM.	FOR 200V			1
12	M8901594BA0	TRANSFORMER B ASM.	FOR 380V			1
13	17845009	CORD FITTING PLATE				1
14	CM200100001	PE MARK LABEL	FOR 380V			1
15	CM300100001	LABEL	FOR 380V			1
16	E9567319000	EARTH MARK				1
17	E9609603000	STICKER (LARGE)				3
18	M1001590000	CONTROL BOX				1
19	HK026650080	TERMINAL BASE 8P	FOR 200V			1
20	HK054250040	TERMINAL BASE	FOR 380V			2
21	WS0610002KN	SPRING WASHER 6.1X12.2X1.5				4
22	HX00056000B	SPACER				4
23	HX00147000C	SPACER				4
24	HX004070000	BUSH				1
25	HX004100000	BUSH				1
26	HA004250000	SWITCH	EXCEPT JE			1
27	NM3034000SF	FLANGE NUT				4
28	NM3040520SF	FLANGE NUT M4				4
29	SL4030681SF	SCREW M3 L=6				4
30	SL4030891SC	SCREW M3X8				4
31	SL4040881SF	SCREW M4 L=8				4
32	SL4041091SC	SCREW M4 L=10				7
33	SL4041081SF	SCREW M4 L=10	FOR 200V			2
34	SM4031851SR	SCREW	FOR 380V			4
35	WS0310702KS	SPRING WASHER	FOR 380V			4
36	SL4040681SC	COMBINATION SCREW M4X8				4
37	SL4041091SC	SCREW M4 L=10				2
38	SL4041091SC	SCREW M4 L=10				6
39	SL4051091SC	SCREW M5X0.8 L=10				4
40	SL4041091SC	SCREW M4 L=10				4
41	HX00123000B	CABLE CLIP				1
42	SK3482001SE	WOOD SCREW D=4.8 L=20	EXCEPT JE			2
43	CM300100101	DANGER LABEL (SMALL)	FOR 200V(FOR USE IN JAPAN)			1
44	G6705152U0A	LABEL	FOR 200V(FOR EXPORT)			1
45	SM3065052TC	SCREW				4
46	WP0651001SC	WASHER				4
47	M85205920A0	FAN COVER ASM.				1

# CONTROL BOX COMPONENTS

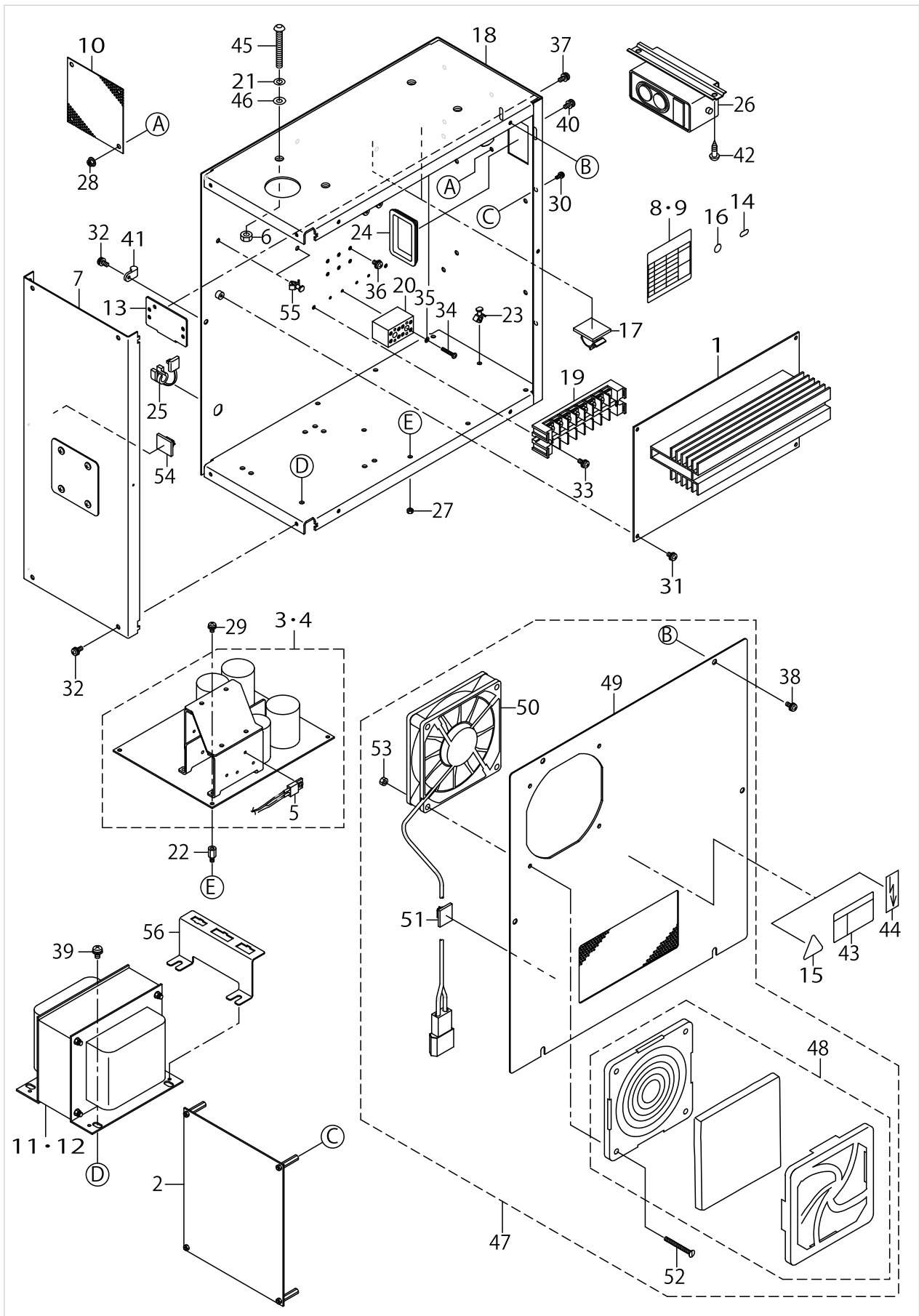

## CONTROL BOX COMPONENTS

No.	Parts No.	Parts name	Remarks	Level	Cons	Qty
48	HM000630010	FILTER		*		1
49	M10025920A0	CONTROL BOX COVER ASM.		*		1
50	M85105810A0	FAN ASM.		*		1
51	E9607603000	STICKER (SMALL)		*		1
52	SM1044050SM	SCREW M4X0.7 L=40		*		4
53	NM3040520SF	FLANGE NUT M4		*		4
54	E9607603000	STICKER (SMALL)				2
55	HX001470000	PCB HOLDER				4
56	M1007594000	CONNECTOR STOPPER PLATE				1

OPERATION BOX & PEDAL COMPONENTS

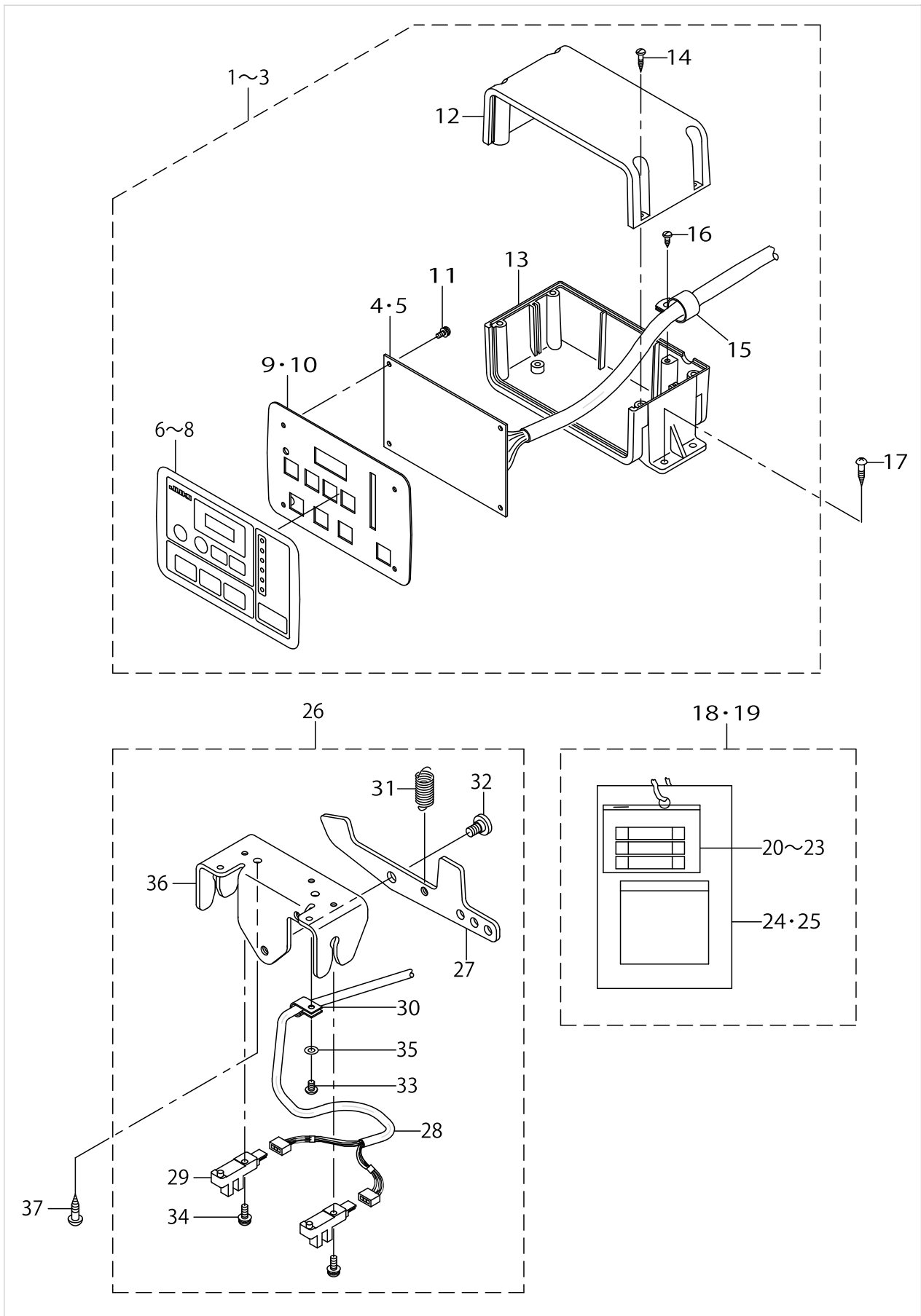

OPERATION BOX & PEDAL COMPONENTS

No.	Parts No.	Parts name	Remarks	Level	Cons	Qty
1	M8510594AA0	OPERATION BOX A ASM.	FOR USE IN JAPAN			1
2	M8510594BA0	OPERATION BOX B ASM.	FOR EXPORT			1
3	M8510594CA0	OPERATION BOX C ASM.	FOR AW-2D			1
4	M86065940A0	OPERATION CIRCUIT BOARD ASM.	EXCEPT FOR AW-2D	*		1
5	M86075940A0	CIRCUIT BOARD AW ASM.	FOR AW-2D	*		1
6	M300259400A	PANEL SHEET(JAPANESE)	FOR USE IN JAPAN	*		1
7	M300259400B	PANEL SHEET(ENGLISH)	FOR EXPORT	*		1
8	M300259400C	OPERATION PANEL SEAT(JAPANESE)	FOR AW-2D	*		1
9	M1012592000	OPERATION PANEL PLATE	EXCEPT FOR AW-2D	*		1
10	M1012594000	OPERATION PANEL PLATE(WITH AW)	FOR AW-2D	*		1
11	SL4030881SF	SCREW		*		4
12	M1011590000	OPERATION BOX B		*		1
13	M1010590000	OPERATION BOX A		*		1
14	ST40316110R	TAPPING SCREW D=3 L=16		*		4
15	EA9502B0500	CABLE CLIP		*		1
16	SV4031006SR	SCREW M3 L=10		*		1
17	SK3382001SE	SCREW D=3.8 L=20				4
18	M85995900A0	ACCESSORIES PART ASM.	FOR 200V			1
19	M8599590AA0	ACCESSORIES PART A ASM.	FOR 380V			1
20	HF001301000	TIMING LAG FUSE		*		1
21	HF0041080P0	FUSE 8A		*		1
22	E8523304000	FUSE 10A		*		1
23	HF002900300	FUSE 250V 3A		*		1
24	M300451100A	VOLTAGE INDICATION CARD,A	FOR 200V	*		1
25	M3003580000	VOLTAGE INDICATION CARD,B	FOR 380V	*		1
26	M85205900A0	1-PEDAL ASM.	EXCEPT FOR AW-2D			1
27	M1031590000	PEDAL SWITCH LEVER		*		1
28	M90115900A0	PEDAL SWITCH CABLE ASM.		*		1
29	HD002230000	PHOTO SENSOR		*		2
30	HX001230000	CABLE CLIP		*		1
31	B2583210D00	SPRING		*		1
32	SD0800331TH	HINGE SCREW D=8 H=3.25		*		1
33	SM4040601SC	SCREW M4X0.7 L=6		*		1
34	SL4041291SC	SCREW M4 L=12		*		2
35	WP0430801SC	WASHER 4.3X9X0.8		*		1
36	M1030590000	PEDAL SWITCH FRAME		*		1
37	SK3482001SE	WOOD SCREW D=4.8 L=20				2



HEATER UNIT COMPONENTS (Z TYPE)

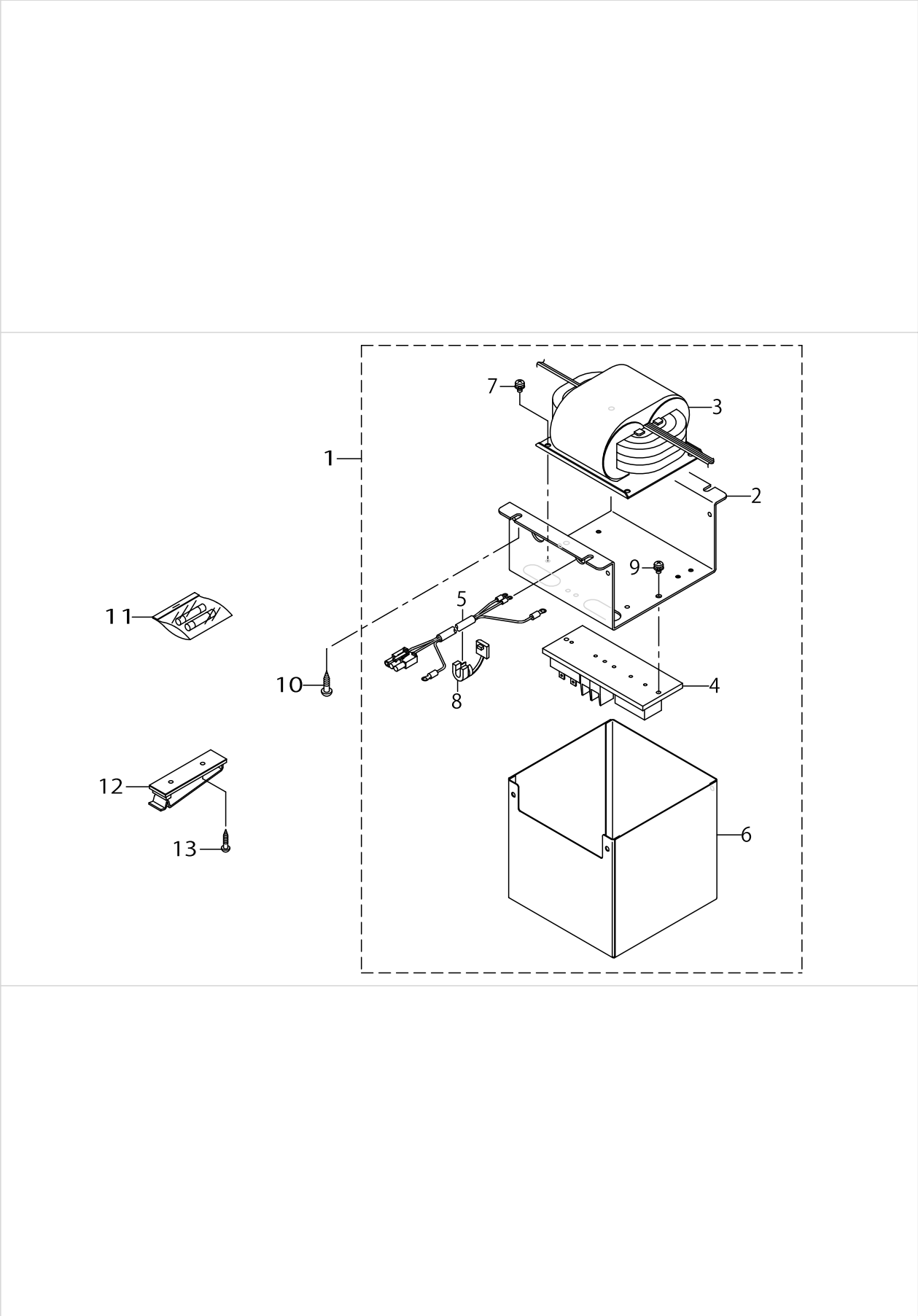

HEATER UNIT COMPONENTS (Z TYPE)

No.	Parts No.	Parts name	Remarks	Level	Cons	Qty
1	M85215940A0	HEATER UNIT ASM.				1
2	M1022594000	TRANSFORMER FITTING BASE		*		1
3	M89025940A0	HEATER TRANSFORMER ASM.		*		1
4	M85225940A0	HEATER SWITCH ASM.		*		1
5	M90215940A0	HEATER POWER SOURCE CORD ASM.		*		1
6	MAT00616000	CONTROL UNIT COVER		*		1
7	SL4040881SF	SCREW M4 L=8		*		4
8	HX004100000	BUSH		*		1
9	SL4040881SF	SCREW M4 L=8		*		2
10	SK3482001SE	WOOD SCREW D=4.8 L=20				4
11	M85995940A0	ACCESSORIE PART ASM.				1
12	M964051000A	CABLE CLIP				1
13	SK3382001SE	SCREW D=3.8 L=20				2

EXTENSION CABLE COMPONENTS

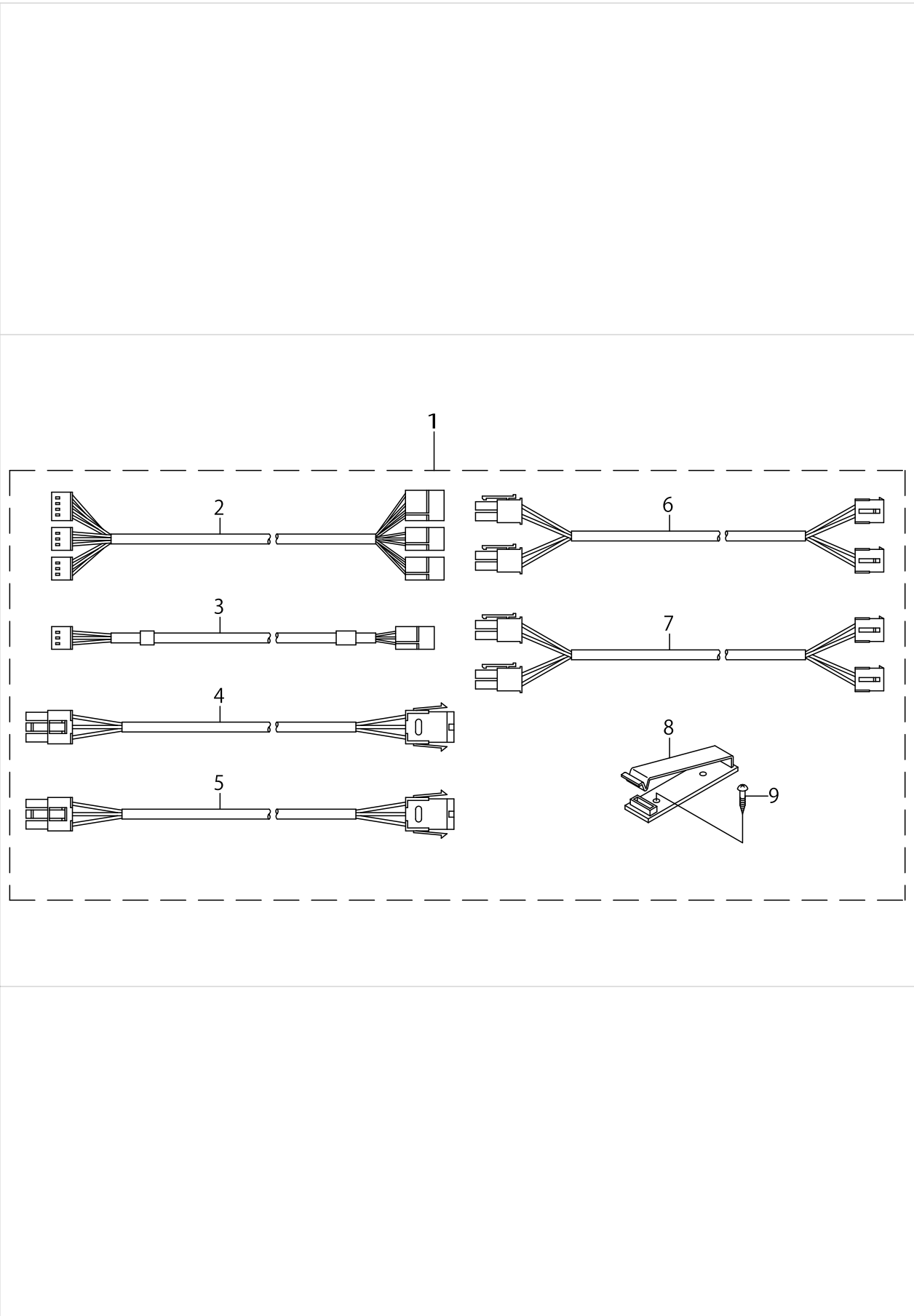

EXTENSION CABLE COMPONENTS

No.	Parts No.	Parts name	Remarks	Level	Cons	Qty
1	M85985920A0	EXTENSION CABLE MAS.ASM.	FOR JUS			1
2	M90445920A0	SENSOR EXTENSION CABLE ASM.		*		1
3	M90475900A0	SENSOR EXTENSION CABLE ASM.		*		1
4	M90415900A0	EXTENSION CABLE ASM.		*		1
5	M90425900A0	EXTENSION CABLE ASM.		*		1
6	M90435900A0	SOLENOID EXTENSION CABLE ASM.		*		1
7	M90435920A0	SOLENOID EXTENSION CABLE A ASM		*		1
8	M964051000A	CABLE CLIP		*		1
9	SK3382001SE	SCREW D=3.8 L=20		*		2



WIRING DIAGRAM

No.	Parts No.	Parts name	Remarks	Level	Cons	Qty
1	M90015900A0	MAIN POWER CORD ASM.				1
2	M90105810A0	FAN CONNECTING CORD ASM.				1
3	M89105900A0	THERMOSTAT ASM.				1
4	M90085800A0	SERVO SIGNAL CORD ASM.				1
5	M90205800A0	TRANSFORMER POWER CORD ASM.	FOR 200V			1
6	M9020580AA0	TRANSFORMER POWER CORD ASM.,A	FOR 380V			1
7	M90225900A0	POWER CORD ASM.	FOR 200V			1
8	M90235900A0	POWER CORD A ASM.	FOR 380V			1
9	M90025800A0	SERVO POWER CORD ASM.,B				1
10	M90315900A0	SERVO POWER CORD ASM.,A				1
11	M85205900A0	1-PEDAL ASM.				1
12	M90175800A0	POWER CABLE ASM.	FOR 200V(3-PHASE), 380V(FOR EXPORT)			1
13	M90285800A0	POWER CABLE ASM.	FOR MC-594-ΔM			1
14	M90245800A0	POWER CABLE ASM.,100V	FOR 1-PHASE			1
15	HA004250000	SWITCH				1
16	M90145800A0	RELAY CABLE ASM.				1

ACCESSORIE PART COMPONENTS

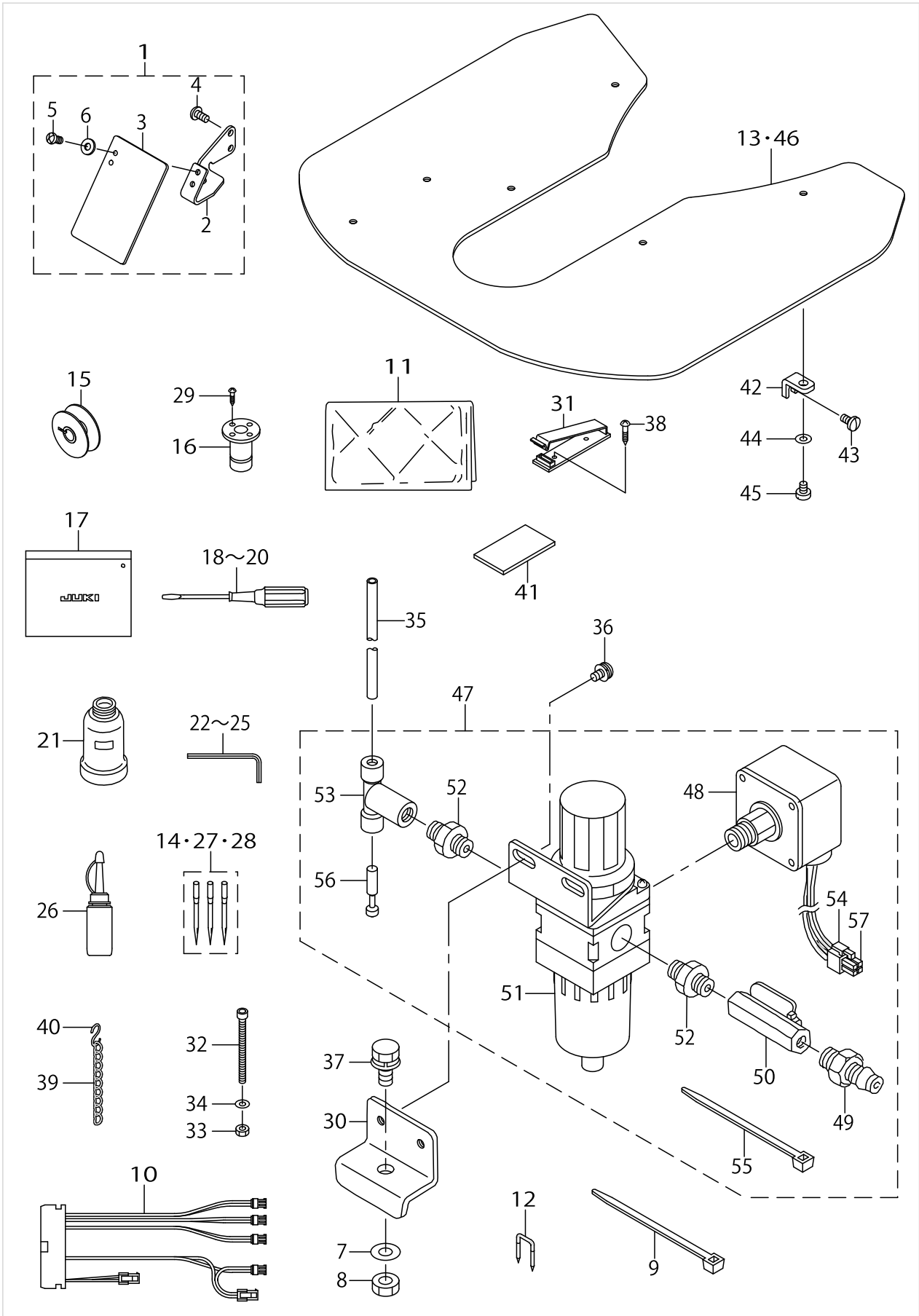

ACCESSORIE PART COMPONENTS

No.	Parts No.	Parts name	Remarks	Level	Cons	Qty
1	40052806	SAFETY PLATE ASM				1
2	40051987	SAFETY PLATE BASE		*		1
3	26037200	SAFETY PLATE		*		1
4	SS4110715SP	SCREW 11/64-40 L=7		*		2
5	SM4040655SP	SCREW M4 L=6		*		2
6	WP0450801SD	WASHER 4.5X10X0.8		*		2
7	WP0871602SE	WASHER 8.7X18X1.6				1
8	NM6080721SE	NUT M8				1
9	EA9500B0100	CABLE BAND				5
10	14444657	ELECTROMAGNETIC VALVE ASM.				1
11	26234005	VINYL COVER				1
12	MAO11532000	CORD STAPLE				10
13	14442008	NEEDLE PLATE AUXILIARY COVER	FOR AW-2D			1
14	MDP170B2302	NEEDLE DPX17#23-2	G TYPE			1
15	14436406	BOBBIN	EXCEPT FOR AW-2D			1
16	B8202205000	OIL MANAGEMENT				1
17	22932800	ACCESSORIE BAG				1
18	22933006	SCREW DRIVER,LARGE				1
19	22933105	SCREW DRIVER,MIDDLE				1
20	22933204	SCREW DRIVER,SMALL				1
21	B9121012000	OIL CAN				1
22	B9140372000	HEXAGONAL WRENCH, SMALL				1
23	10038909	HEXAGONAL WRENCH				1
24	J106600000D	HEXAGONAL WRENCH KEY				1
25	GCT02906000	HEXAGONAL SPANNER				1
26	B91212200A0	OILER (CONTAINING NO.2 OIL)				1
27	MDP170B2602	NEEDLE DPX17 #26-2				1
28	MDP170B1802	NEEDLE DPZ17#18-2	H TYPE			1
29	SK3311601SE	WOOD SCREW D=3.1 L=16				4
30	40023662	FILTER INSTALLING PLATE				1
31	M964051000A	CABLE CLIP	Z TYPE			1
32	SM6067552TP	HEXAGONAL-HOLE BOLT M6 L=75				1
33	NM6060001SC	NUT M6				1
34	WP0651646SC	WASHER				1
35	BT0600401EB	TUBE				1
36	SL4051091SC	SCREW M5X0.8 L=10				2
37	SL9082093SE	SCREW				1
38	SK3382001SE	SCREW D=3.8 L=20	Z TYPE			1
39	B8103980000	CHAIN	EXCEPT FOR AW-2D			1
40	B8133019000	S SHAPED HOOK	EXCEPT FOR AW-2D			2
41	B2564215000	SPONGE		*		1
42	B1113223C00	COVER SUPPORTER				4
43	SS7110840SP	SCREW 11/64-40 L=7.8				4
44	WP0520656SA	WASHER 5.2X9.5X0.6				4
45	SS6110610TP	SCREW 11/64-40 L=6				4
46	14223010	NEEDLE PLATE SUPPORT COVER	EXCEPT FOR AW-2D			1
47	B47152150A0	FILTER REGULATOR ASM.				1



ACCESSORIE PART COMPONENTS

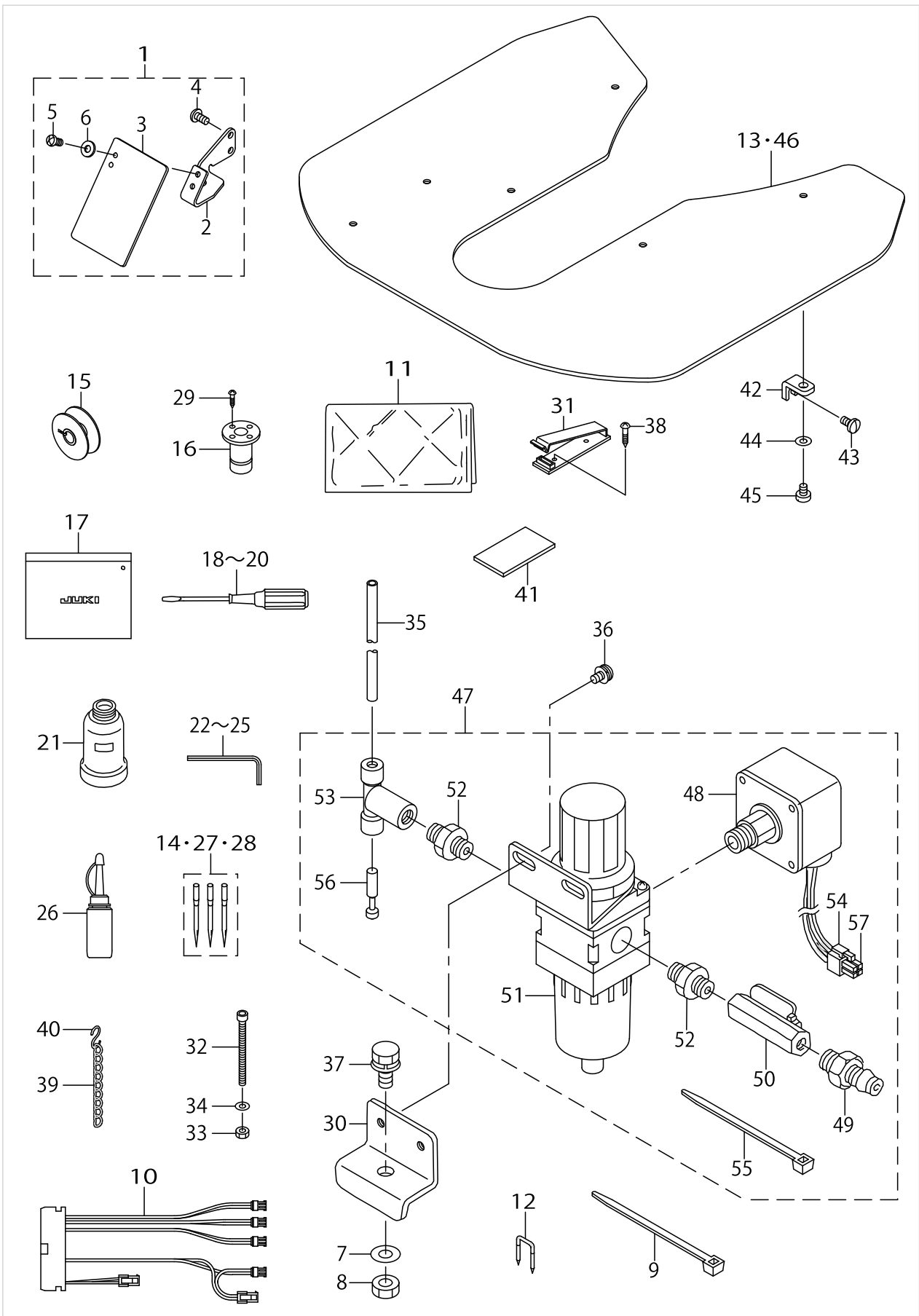

ACCESSORIE PART COMPONENTS

No.	Parts No.	Parts name	Remarks	Level	Cons	Qty
48	G8124270000	AIR PRESSUE SWITCH		*		1
49	PJ309005203	QUICK JOINT PLUG		*		1
50	G5430116000	AIR COCK		*		1
51	PF0552040B0	FILTER REGULATOR		*		1
52	PJ030520001	RING JOINT (NIPPLE)		*		2
53	PJ305065202	TEE		*		1
54	HK034610040	HOUSING		*		1
55	EA9500B0100	CABLE BAND		*		5
56	PX950009000	PLUG		*		1
57	HK034640000	PIN CONTACT		*		3

TABLE COMPONENTS (EXCEPT FOR AW-2D)

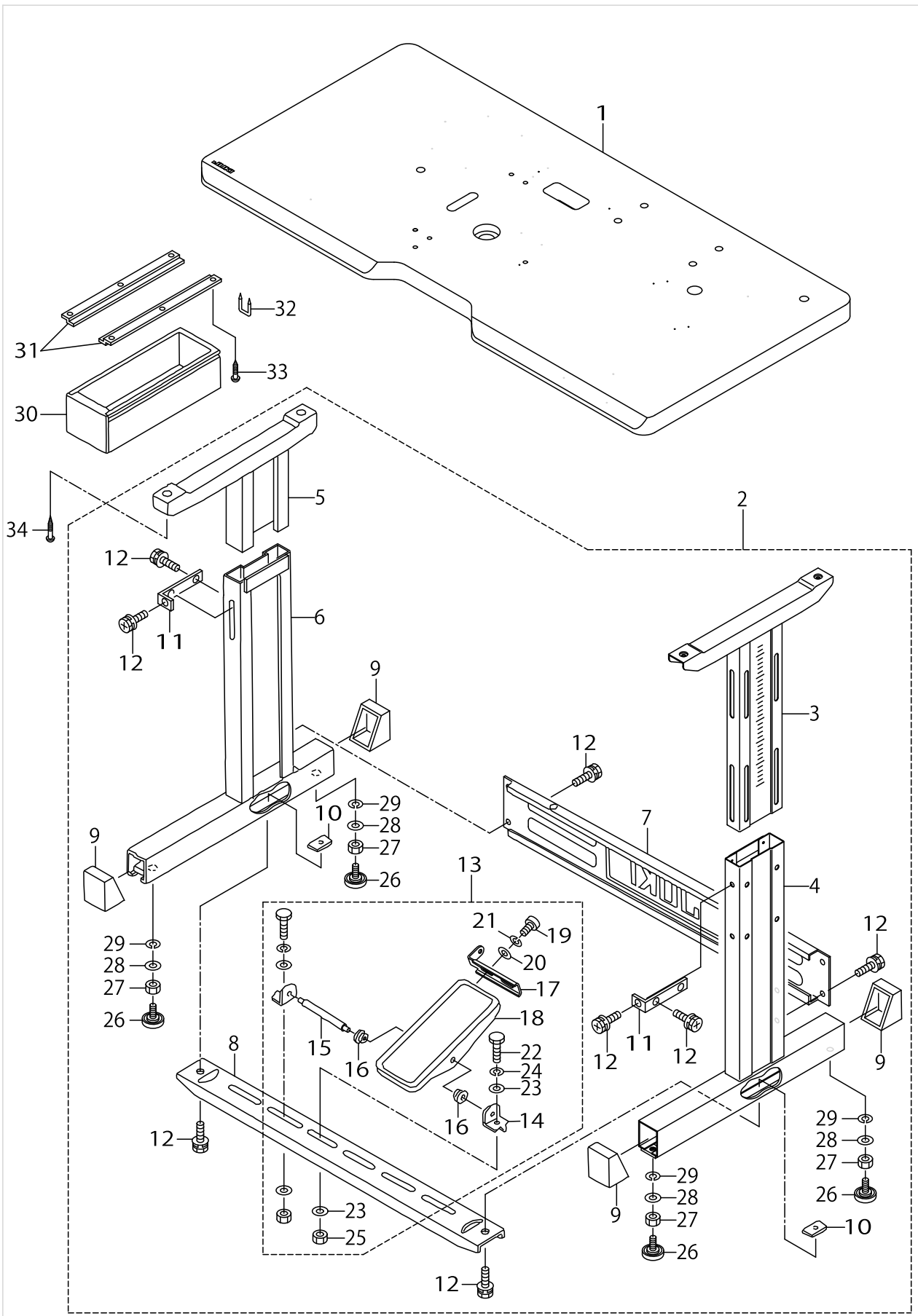
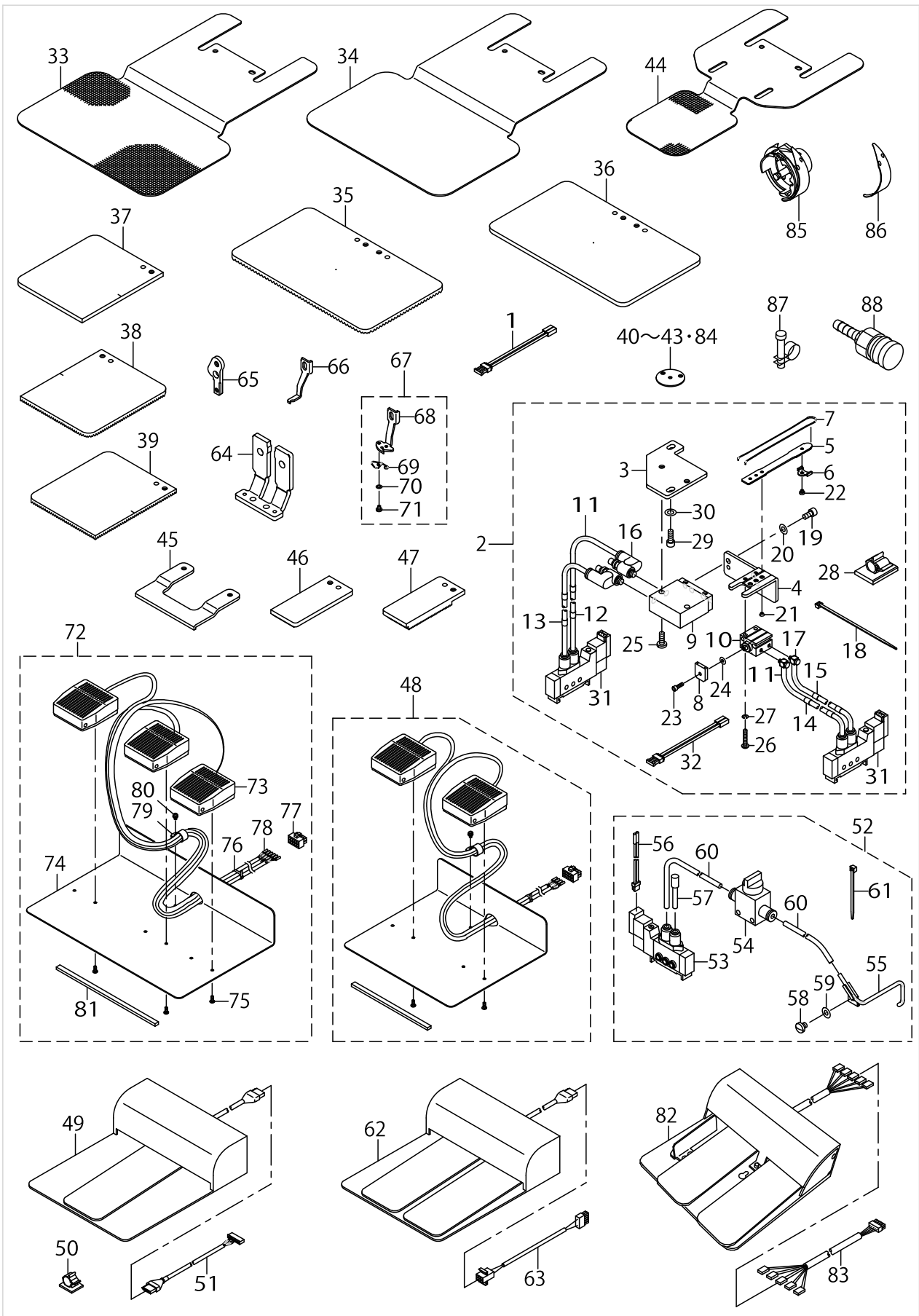

TABLE COMPONENTS (EXCEPT FOR AW-2D)

No.	Parts No.	Parts name	Remarks	Level	Cons	Qty
1	14117519	UPRIGHT TABLE				1
2	14118053	T-STAND COMPL.				1
3	14118152	UPPER STAND ASM.,RIGHT		*		1
4	14118251	STAND ASM.,RIGHT		*		1
5	B8101210AAB	UPPER STAND ASM.		*		1
6	B8105210AAA	STAND ASM.		*		1
7	11158300	STAND SIDE SUPPORT		*		1
8	11158409	STAND SIDE SUPPORT		*		1
9	11158607	RUBBER CAP		*		4
10	17007402	NUT		*		2
11	11158516	UPPER STAND PLATE		*		2
12	SL9082091SE	WASHER HEXAGONAL BOLT		*		12
13	13817754	Z-STAND PEDAL ASM.		*		1
14	11159001	PEDAL SHAFT BRACKET		*		2
15	B8153771000	PEDAL CONNECTING ROD		*		1
16	D8113555B00	PEDAL BUSHING		*		2
17	GPF06080000	PEDAL ADJUSTING PLATE		*		1
18	GPF060600A0	PEDAL ASM.		*		1
19	SM9061203SE	SCREW M6 L=12		*		2
20	WP0671016SE	WASHER 6.7X13X1		*		2
21	WS0621210KR	SPRING WASHER 6.2X11.4X1.2		*		2
22	SM9082023SE	SCREW M8 L=20		*		2
23	WP0871602SE	WASHER 8.7X18X1.6		*		4
24	WS0861410KR	SPRING WASHER 8.6X15X1.4		*		2
25	NM6080721SE	NUT M8		*		2
26	B81085550A0	ADJUSTING SCREW ASM. WITH CAP		*		4
27	NM6120001SE	NUT M12		*		4
28	WP1302501SE	WASHER M12		*		4
29	WS1253010KN	SPRING WASHER 12.5X21.5X3		*		4
30	11155108	DRAWER				1
31	11155207	DRAWER SUPPORT				2
32	D8204555D00	DRAWER STOPPER				1
33	SK3311601SE	WOOD SCREW D=3.1 L=16				6
34	SK3513201SE	WOOD SCREW D=5.1 L=32				4

OPTIONAL PART COMPONENTS(1)



OPTIONAL PART COMPONENTS(1)

No.	Parts No.	Parts name	Remarks	Level	Cons	Qty
1	14204754	SOLENOID VALVE CONNECTOR ASM.				1
2	14445050	THREAD CLAMP DEVICE ASM.				1
3	14445407	THREAD CLAMP BASE		*		1
4	14445308	THREAD CLAMP CYLINDER BASE		*		1
5	14445100	THREAD CLAMP GUIDE A		*		1
6	14445209	THREAD CLAMP GUIDE B		*		1
7	14445506	THREAD CLAMP WIRE		*		1
8	14445605	THREAD CLAMP WIRE JOINT		*		1
9	PA100101900	AIR CYLINDER		*		1
10	PA060060100	AIR CYLINDER		*		1
11	BT0400251EB	URETHANE HOSE, BLACK		*		1
12	HX00295000F	WIRE MARK (7)		*		1
13	18035709	WIRE MARK (8)		*		2
14	18035808	WIRE MARK (9)		*		2
15	18035907	WIRE MARK (10)		*		2
16	PC010519000	SPEED CONTROLLER		*		2
17	PJ046039001	ELBOW		*		2
18	EA9500B0100	CABLE BAND		*		2
19	SM6040802TP	SCREW M4X0.7 L=8		*		2
20	WP0430801SE	WASHER 4.3X9X0.8		*		2
21	SS1060210TP	SCREW 3/32-56 L=2.2		*		3
22	SS6060210SP	SCREW 3/32-56 L= 1.9		*		1
23	SM6850802TN	SCREW M2.5 L=8		*		1
24	WP0250501SC	WASHER 2.5X6.5		*		2
25	SS7111810TP	SCREW 11/64-40 L=18		*		2
26	SM4031601SN	SCREW M3X0.5 L=16		*		2
27	WS0310002KR	SPRING WASHER 3.1X5.9X0.7		*		2
28	HX00305000A	WIRE HARNESS PARTS		*		3
29	SS6110610TP	SCREW 11/64-40 L=6		*		2
30	WP0520656SA	WASHER 5.2X9.5X0.6		*		2
31	PV150209000	5 PORT SOLENOID VALVE		*		2
32	14204754	SOLENOID VALVE CONNECTOR ASM.		*		2
33	14224000	LOWER PLATE BLANK				1
34	14224109	LOWER PLATE BLANK				1
35	B2553210D0A	FEEDING FRAME BLANK				1
36	B2553210D0B	FEEDING FRAME BLANK				1
37	B2554210D0A	FEEDING FRAME BLANK				1
38	B2554210D0B	FEEDING FRAME BLANK,RIGHT				1
39	B2554210D0C	FEEDING FRAME BLANK,LEFT				1
40	14439400	NEEDLE HOLE GUIDE D=2	H,G TYPE			1
41	14439509	NEEDLE HOLE GUIDE D=2.3	H,G TYPE			1
42	14439806	NEEDLE HOLE GUIDE D=3	HOT WIRE TYPE			1
43	14439905	NEEDLE HOLE GUIDE D=4	HOT WIRE TYPE			1
44	14444202	LOWER PLATE BLANK				1
45	14444301	LOWER PLATE GUIDE				1
46	14444004	OUTER FRAME RIGHT BLANK				1
47	14444103	OUTER FRAME LEFT BLANK				1

OPTIONAL PART COMPONENTS(1)

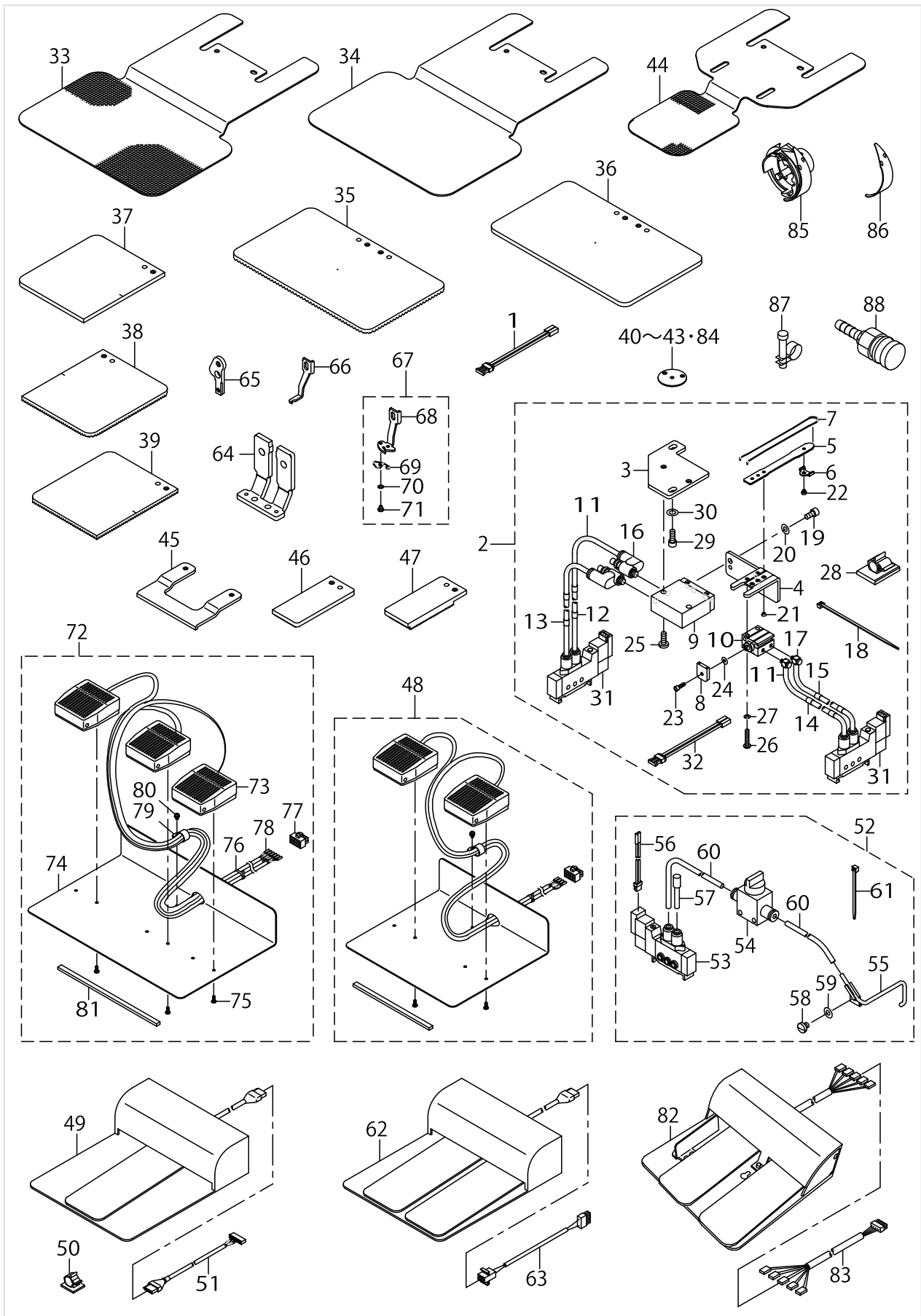

OPTIONAL PART COMPONENTS(1)

No.	Parts No.	Parts name	Remarks	Level	Cons	Qty
48	M85205800A0	2-PEDAL ASM.				1
49	GPK570010B0	PEDAL SWITCH ASM.				1
50	E9607603000	STICKER (SMALL)				2
51	M90135900A0	PK57 TRANSFER CABLE ASM.				1
52	14225056	NEEDLE COOLER ASM.				1
53	PV150209000	5 PORT SOLENOID VALVE		*		1
54	PV010011000	VALVE		*		1
55	B47202150A0	NEEDLE COOLER UNION		*		1
56	14204754	SOLENOID VALVE CONNECTOR ASM.		*		1
57	PX500014000	PLUG		*		1
58	SS7110510SP	SCREW 11/64-40 L=5		*		1
59	WP0450000SD	WASHER 4.5X8X0.5		*		1
60	BT0400251EB	URETHANE HOSE, BLACK		*		2
61	HX002330000	CLIP		*		3
62	M85905130AA	PEDAL SWITCH ASM.				1
63	M90315800A0	2-PEDAL CONNECTING CORD ASM.				1
64	14437255	SLIDER PLATE COMPL.				1
65	14445902	WIPER BASE				1
66	14446009	WIPER				1
67	14446157	THREAD CLAMP WIPER ASM.				1
68	14446108	THREAD CLAMP WIPER		*		1
69	14147805	SPRING		*		1
70	WP0280500SC	WASHER		*		2
71	SS7060310SP	SCREW 3/32-56 L=3		*		2
72	M85215800A0	3-PEDAL ASM.				1
73	HA004260000	FOOT SWITCH		*		3
74	M1016580000	SWITCH MOUNT PLATE,B		*		1
75	ST5041051SN	SCREW		*		6
76	EA9500B0100	CABLE BAND		*		4
77	HK034610100	10P CONNECTOR		*		1
78	HK034640000	PIN CONTACT		*		6
79	EA9502B0500	CABLE CLIP		*		1
80	SL4040881SF	SCREW M4 L=8		*		1
81	GPK26002000	PEDAL BASE RUBBER		*		1
82	GPK470010AB	3-PEDAL ASM.				1
83	M90255800A0	PEDAL SWITCH TRANSFER CABLE ASM.				1
84	14440101	ELLIPSE NEEDLE HOLE GUIDE	G TYPE			1
85	14436703	LUBRICATION HOOK B ASM.				1
86	40019012	SCREW 11/64-40 L=5	Z TYPE			1
87	PB000010000	HOSE BAND				1
88	PJ309520001	SOCKET				1



OPTIONAL PART COMPONENTS(2)

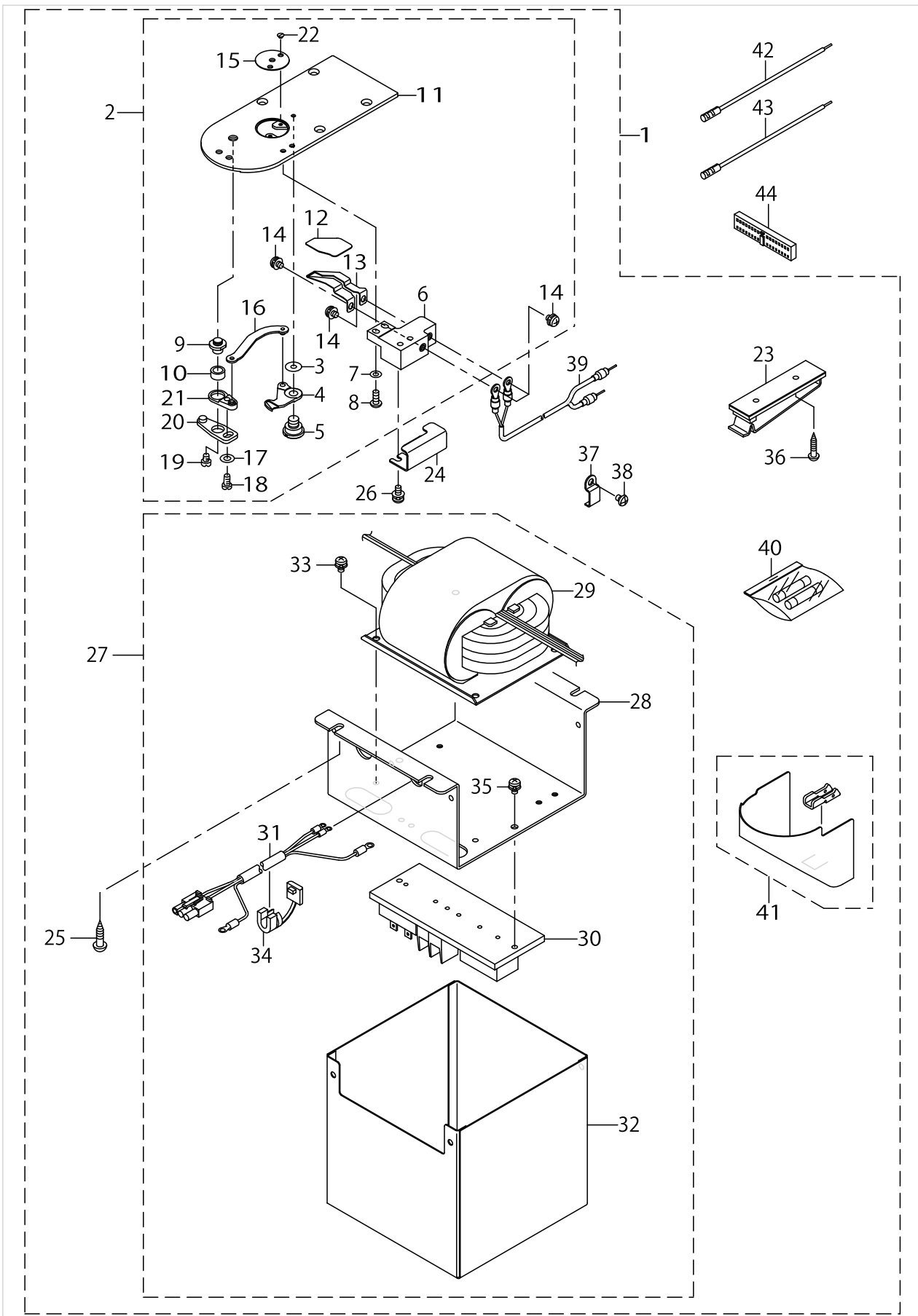

OPTIONAL PART COMPONENTS(2)

No.	Parts No.	Parts name	Remarks	Level	Cons	Qty
1	14447056	HOT WIRE THREAD TRIMMER UNIT	H,G TYPE			1
2	40023523	HOT WIRE NEEDLE ASM		*		1
3	B242328000B	MOVING KNIFE WASHER B		*		1
4	14441208	MOVING KNIFE		*		1
5	B2417210000	MOVING KNIFE HINGE SCREW		*		1
6	40022013	HOT WIRE BASE ASM		*		1
7	WP0371016SD	WASHER 3.7X8X1		*		2
8	SS4091015SP	SCREW 9/64-40 L=10		*		2
9	B2417280000	THREAD CUTTER LEVER SHAFT		*		1
10	B2416280000	THREAD CUTTING LEVER RING		*		1
11	14439103	NEEDLE PLATE		*		1
12	40039621	INSULATING SHEET B		*		1
13	40022223	HOT WIRE PLATE		*		1
14	SL4040681SC	COMBINATION SCREW M4X8		*		4
15	14440002	ELLIPSE NEEDLE HOLE GUIDE		*		1
16	14440457	MOVING KNIFE LINK COMPL.		*		1
17	WP0450846SP	WASHER		*		1
18	SS7110740TP	SCREW 11/64-40 L=7		*		1
19	SS6110430TP	SCREW 11/64-40 L=4.0		*		1
20	B24142800A0	THREAD CUTTER LEVER ASM., LARGE		*		1
21	14440556	LEVER TYPE COMPL.		*		1
22	SS1060210TP	SCREW 3/32-56 L=2.2		*		2
23	M964051000A	CABLE CLIP		*		1
24	14441901	HOT WIRE BASE COVER		*		1
25	SK3482001SE	WOOD SCREW D=4.8 L=20		*		4
26	SL4041091SC	SCREW M4 L=10		*		2
27	M85215940A0	HEATER UNIT ASM.		*		1
28	M1022594000	TRANSFORMER FITTING BASE		*		1
29	M89025940A0	HEATER TRANSFORMER ASM.		*		1
30	M85225940A0	HEATER SWITCH ASM.		*		1
31	M90215940A0	HEATER POWER SOURCE CORD ASM.		*		1
32	MAT00616000	CONTROL UNIT COVER		*		1
33	SL4040881SF	SCREW M4 L=8		*		4
34	HX004100000	BUSH		*		1
35	SL4040881SF	SCREW M4 L=8		*		2
36	SK3382001SE	SCREW D=3.8 L=20		*		2
37	B3509210000	OIL TUBE HOLDER C		*		3
38	SS4110515SP	SCREW 11/64-40 L=5		*		3
39	14442255	HEATER CORD ASM.		*		1
40	M85995940A0	ACCESSORIE PART ASM.		*		1
41	14435358	HOOK COVER ASM.		*		1
42	M90325800A0	I/O CORD (RED) ASM.				1
43	M90335800A0	I/O CORD (BLACK) ASM.				1
44	HK014820340	CONNECTOR 34P				1



## HOW TO MAKE USE OF THIS PARTS LIST

### 1.Explanation of codes

1)"\*"mark.....means this part is changed from the previous parts book.

As to the details of the change, refer to the "List for information of change".

2)"#01".....refer to "Note" explanation at bottom of page.

### 2.Codes on the "Qty" column

- Each numeral indicates the number of parts required.
- "0.1" and "2.5" indicate the length (in meters) of the respective parts.

3.Parentheses mean that the corresponding part is a subpart that constructs an assembly part.

4.Dotted lines on the Figures indicate assembly parts.

### 1."注記"欄の記号説明

1) "\*"印.....前回のパーツブックに比較して今回変更された部品を意味します。

変更内容は、"変更情報リスト"を参照してください。

2) "#01".....ページ下の"注記"の説明を参照してください。

2.数量欄の数字は、個数を表し、0.1、2.5等の数値は、長さ（単位メートル）を表します。

3.数量欄の（ ）は、組部品を構成している子部品であることを意味します。

4.イラストページの-----枠は、組構成であることを意味します。

# NUMERICAL INDEX OF PARTS

PART NO	PAGE	REF NO.	PART NO	PAGE	REF NO.	PART NO	PAGE	REF NO.
10006005	28	51	14109250	30	26	14219604	44	25
10038909	62	22~25	14109300	30	16	14219711	44	26
10126704	44	42	14112502	38	10	14220503	4	66
10502300	2	17	14113450	2	47	14220750	4	54
10570307	28	63	14114300	44	3	14221253	40	51
11043304	30	8	14114409	44	4	14221352	40	52
11072402	4	50	14114508	10	33	14223010	62	13·46
11072709	24	13	14114607	44	13	14224000	68	33
11155108	66	30	14115356	12	62	14224109	68	34
11155207	66	31	14115653	6	32	14225056	70	52
11158300	66	7	14117519	66	1	14404107	10	41
11158409	66	8	14118053	66	2	14431407	10	2
11158516	66	11	14118152	66	3	14431605	12	59
11158607	66	9	14118251	66	4	14431704	10	6
11159001	66	14	14147805	70	69	14431803	10	9
11404308	6	14	14200802	2	22	14431852	10	7
12219705	44	33	14200901	4	65	14431902	12	65
13502307	4	60	14201602	6	1	14432009	10	15
13508403	20	9	14203806	14	11	14432157	10	13
13508700	20	18	14203905	14	12	14432306	20	32
13518501	20	35	14204754	68	56	14432454	20	34
13530308	44	45	14204754	70	56	14432504	20	36
13530357	44	44	14204911	14	2	14432702	10	43
13705108	6	11	14206650	16	36	14432959	28	60
13788302	26	21	14209308	16	38	14433007	28	67
13816855	20	16	14214019	38	13	14433106	28	69
13817408	26	15	14214308	38	45	14433205	28	66
13817754	66	13	14214712	38	22	14433601	16	12·13
13860200	18	50	14214902	38	37	14433858	16	27
13860606	18	51	14215057	38	38	14433908	16	30
14100309	2	12	14215305	38	41	14434005	16	22
14100408	2	2	14215404	38	40	14434104	16	26
14100457	2	1	14215602	40	57	14434203	16	24
14100705	2	6	14215701	38	14	14434302	16	32
14100754	2	5	14215909	40	58	14434401	16	21
14101208	4	61	14216006	40	53	14434500	16	4
14102404	10	1	14216204	40	59	14434609	16	8
14102503	10	5	14216303	38	3	14434708	16	18
14107502	26	1	14216352	38	1	14434807	16	42
14107700	26	2	14216410	38	7	14435200	22	63
14108500	30	2	14217202	42	3	14435358	20	7
14108609	30	3	14217301	42	38	14435358	72	41
14108807	30	6	14217400	42	39	14435507	20	1
14108906	30	7	14218002	42	4	14435606	20	5
14108955	30	5	14219513	44	12	14435705	20	6

# NUMERICAL INDEX OF PARTS

PART NO	PAGE	REF NO.	PART NO	PAGE	REF NO.	PART NO	PAGE	REF NO.
14435804	20	11	14440002	72	15	14446504	22	60
14435903	20	13	14440101	70	40~43·84	14446603	22	61
14436000	20	20	14440309	34	14	14447056	72	1
14436158	20	22~24	14440457	34	40	14447106	20	25·26
14436208	22	56	14440457	72	16	14447205	20	25·26
14436257	22	55	14440556	34	45	14447304	20	27~29
14436307	20	22~24	14440556	72	21	14447403	20	27~29
14436406	22	39·52	14441000	34	15·24	14447502	20	27~29
14436406	62	15	14441109	34	15·24	14447908	38	17
14436554	20	22~24	14441208	34	36	14448005	38	21
14436604	34	54	14441208	72	4	14449250	38	6
14436604	36	54	14441901	36	52	17007402	66	10
14436703	70	85	14441901	72	24	17845009	50	13
14436802	42	1	14442008	62	13·46	18035709	68	13
14436901	42	13	14442255	36	49	18035808	68	14
14437057	42	7	14442255	72	39	18035907	68	15
14437156	42	8	14442305	28	59	21060009	28	53
14437255	70	64	14442404	30	28	22528509	28	54
14437651	24	1	14442503	6	37	22684906	16	7
14437750	24	2	14442552	6	36	22901805	6	3
14437800	24	7	14442651	6	42	22904155	10	26
14437909	24	8	14443006	2	24	22906408	12	49
14438006	24	9	14443105	2	25	22906457	12	48
14438105	24	10	14443204	44	2	22907554	16	1
14438204	24	11	14443303	44	7	22917058	42	34
14438303	24	12	14443402	44	40	22917157	26	36
14438402	28	55	14444004	68	46	22920508	6	10
14438550	28	56	14444103	68	47	22921506	30	31
14438568	28	48	14444202	68	44	22924005	24	28
14438659	26	38	14444301	68	45	22928808	30	30
14438709	26	20	14444657	62	10	22932800	62	17
14438808	32	52	14445050	68	2	22933006	62	18~20
14438907	30	27	14445100	68	5	22933105	62	18~20
14439004	30	34	14445209	68	6	22933204	62	18~20
14439103	34	32	14445308	68	4	22951008	30	20
14439103	72	11	14445407	68	3	23630007	44	19
14439152	34	1·2	14445506	68	7	23636657	2	46
14439251	34	1·2	14445605	68	8	23638109	6	38
14439400	68	40~43·84	14445902	70	65	23638208	6	40
14439509	68	40~43·84	14446009	70	66	23638307	6	39
14439608	34	3·4	14446108	70	68	23638406	6	41
14439707	34	3·4	14446157	70	67	26037200	62	3
14439806	68	40~43·84	14446207	22	57	26203208	10	44
14439905	68	40~43·84	14446306	22	58	26211755	2	8
14440002	34	29	14446405	22	59	26211904	6	7

# NUMERICAL INDEX OF PARTS

PART NO	PAGE	REF NO.	PART NO	PAGE	REF NO.	PART NO	PAGE	REF NO.
26212803	12	52	40022226	2	39	B1115210D00	6	46
26218404	26	6	40023523	34	28	B1116210D00	4	63
26218602	30	33	40023523	72	2	B1116804000	30	23
26218651	30	29	40023631	16	3	B1123210D00	6	24
26220400	30	32	40023662	62	30	B1125210D00	6	26
26221101	20	17	40025746	16	35	B1125215P00	6	9
26221200	20	40	40026917	12	55	B1129210000	6	8
26223305	38	19	40028986	40	54	B1144210000	10	37
26226506	30	24	40030828	2	9	B1202210000	10	3
26229302	26	24	40031323	16	39	B1203215000	10	4
26230706	44	11	40031324	18	56	B1212210D00	10	38
26231407	44	16	40039621	34	33	B1223771000	12	66
26231902	44	29	40039621	72	12	B1223771000	20	14
26234005	62	11	40045548	12	68	B1223771000	30	22
26260208	2	26	40045549	16	47	B1231210D00	12	64
26260307	2	27	40045550	18	57	B1306155000	10	11
26260406	2	28	40045552	18	58	B13061550A0	10	10
26260505	2	29	40045553	18	59	B1403280000	10	45
26260604	2	30	40051987	62	2	B1404280000	10	20
26260802	2	31	40052806	62	1	B1406210000	10	47
26261305	2	32	40053326	12	63	B1411804000	10	18
26261503	2	33	40085784	48	2	B1411804A00	20	43~46
26261701	2	34	40085785	48	3	B1411804B00	20	43~46
26500900	26	4	40085786	48	4	B1411804C00	20	43~46
26501205	30	1	40085787	48	5	B1411804D00	20	43~46
26501304	26	5	40085788	48	6	B1414232000	12	51
26501403	38	2	40085789	48	7	B1414232000	38	18
26501502	38	8	40085790	48	8	B1456057000	38	16
26501908	30	4	40085791	48	9	B151902600G	38	48
26502906	16	10	40085792	48	10	B151902600G	40	48
40009290	6	5	40085793	48	11	B160122000J	16	12·13
40009290	26	35	40085794	48	12	B1626220000	42	30
40010414	6	4	40085795	48	13	B1633210D00	16	40
40011144	2	35	40085796	48	16	B1634210D00	16	16
40011360	22	62	40086483	20	15	B1652704000	30	15
40014007	16	11	40096325	48	14	B1820210D00	44	39
40019012	70	86	40096326	48	17	B1821210D00	44	9
40020225	2	23	40096327	48	19	B1901210DA0	10	14
40022013	34	37	40096354	48	1	B1903210000	10	16
40022013	72	6	40150001	50	2	B1903552000	10	19
40022188	20	39·52	40222225	2	38	B1904280000	10	21
40022222	2	36	A1230500000A	10	36	B1905541000	10	17
40022223	34	34	B1111210D00	6	47	B2014372000A	28	70
40022223	72	13	B1113223C00	44	38	B2019372000	26	44
40022224	2	37	B1113223C00	62	42	B2106220000	24	14

# NUMERICAL INDEX OF PARTS

PART NO	PAGE	REF NO.	PART NO	PAGE	REF NO.	PART NO	PAGE	REF NO.
B2107210000	24	15	B2703210000	2	19	CM200100001	50	14
B23022050AA	26	9	B3119771000	26	39	CM300100001	50	15
B2302280000	26	10	B3120125000	26	40	CM300100101	50	43
B2304210D00	26	3	B3120704000	28	52	CM300200002	6	17
B2305205000	26	50	B3125012000	28	49	CM301200001	6	16
B2305205000	28	50	B3126012000	4	48	CM600100101	8	50
B2313280000	26	57	B3126012000	26	43	CQ200000000	44	47
B2313280000	28	57	B3132012000	26	42	CQ202000000	44	5
B2401210D00	30	17	B3132552000	26	18	CQ252000000	46	48
B2408210D00	30	18	B3319704L00	28	68	CQ252200000	2	7
B2411210000	30	25	B3403761000	42	11	CQ252200000	44	21
B24142800A0	34	44	B3501210000	44	10	CS079073BSH	38	36
B24142800A0	72	20	B3509210000	36	57	CS080081BSH	30	35
B2416280000	34	46	B3509210000	72	37	CS0801011TH	22	64
B2416280000	72	10	B3509220000	44	17	CS095081ASH	38	12
B2417210000	34	31	B3518280000	44	36	CS100081CSP	16	23
B2417210000	72	5	B3523980000	44	31	CS100081CSP	20	8
B2417280000	34	47	B3541012000	44	8	CS1201010SH	20	2
B2417280000	72	9	B471122000C	42	41	CS147121ESH	12	58
B242328000A	34	8~12	B471122000D	42	40	D2502232D00	42	31
B242328000B	34	48	B471122000E	24	16	D2587L8WB00	16	37
B242328000B	36	48	B471122000F	24	17	D2587L8WB00	30	38
B242328000B	72	3	B471122000G	42	43	D2588L8WB00	30	39
B242328000C	34	8~12	B471122000H	42	42	D3112L4BB00	26	13
B242328000D	34	8~12	B47152150A0	62	47	D3127555B00	26	46
B242328000E	34	8~12	B47202150A0	70	55	D7133555B00	4	49
B2509704000	38	15	B8101210AAB	66	5	D8113555B00	66	16
B2545280000	26	7	B8103980000	62	39	D8204555D00	66	32
B2553210D0A	68	35	B8105210AAA	66	6	E1612173000	18	54
B2553210D0B	68	36	B81085550A0	66	26	E2193172000	42	32
B2554210D00	42	6	B8133019000	62	40	E2691453000	14	9
B2554210D0A	68	37	B8153771000	66	15	E2692453000	14	10
B2554210D0B	68	38	B8202205000	62	16	E2697453000	14	17
B2554210D0C	68	39	B9121012000	62	21	E2993453000	14	4
B255728000B	16	6	B91212200A0	62	26	E8523304000	54	20~23
B255728000C	42	2	B9140372000	62	22~25	E9567319000	50	16
B2561210D00	42	12	BP500000000	44	46	E9607603000	52	54
B2564215000	62	41	BP600000000	44	20	E9607603000	70	50
B2566210D00	42	10	BT0400251EB	18	48	E9609603000	50	17
B2572210D00	42	5	BT0400251EB	24	18	EA9500B0100	6	44
B2583210D00	54	31	BT0400251EB	42	33	EA9500B0100	24	29
B2610210D00	42	9	BT0400251EB	68	60	EA9500B0100	42	44
B2617771000	30	46	BT0400251EB	70	60	EA9500B0100	44	22
B2626372000	44	34	BT0600401EB	62	35	EA9500B0100	62	55
B2702210000	26	19	BT0700500EA	44	1	EA9500B0100	64	55



# NUMERICAL INDEX OF PARTS

PART NO	PAGE	REF NO.	PART NO	PAGE	REF NO.	PART NO	PAGE	REF NO.
EA9500B0100	68	76	HW500070000	24	5	M85205900A0	54	26
EA9500B0100	70	76	HX00056000B	50	22	M85205900A0	60	11
EA9500B0200	40	55	HX001230000	54	30	M85205920A0	50	47
EA9500B0200	46	49	HX00123000B	50	41	M85215800A0	70	72
EA9502B0500	54	15	HX001470000	52	55	M85215940A0	56	1
EA9502B0500	70	79	HX00147000C	50	23	M85215940A0	72	27
G1216870000	10	27	HX00150000A	44	32	M85225940A0	56	4
G2303270000	26	23	HX00150000E	4	57	M85225940A0	72	30
G5430116000	64	50	HX00150000J	4	56	M85905130AA	70	62
G5523880000	40	56	HX00150000N	4	55	M85985920A0	58	1
G6705152U0A	50	44	HX002330000	70	61	M85995900A0	54	18·19
G8124270000	64	48	HX00295000F	68	12	M8599590AA0	54	18·19
GAF01007000	10	39	HX00305000A	68	28	M85995940A0	56	11
GAW02502AA0	20	41	HX004070000	50	24	M85995940A0	72	40
GCT02906000	62	22~25	HX004100000	50	25	M8601594AA0	50	1
GPF060600A0	66	18	HX004100000	56	8	M86045900C0	50	3·4
GPF06080000	66	17	HX004100000	72	34	M8604590AC0	50	3·4
GPK26002000	70	81	J106600000D	62	22~25	M86065940A0	54	4·5
GPK470010AB	70	82	M1001590000	50	18	M86075940A0	54	4·5
GPK570010B0	70	49	M10025920A0	52	49	M8901594AA0	50	11·12
HA001690010	4	53	M10035940A0	50	7	M8901594BA0	50	11·12
HA004250000	50	26	M1004581000	50	10	M89025940A0	56	3
HA004250000	60	15	M1007594000	52	56	M89025940A0	72	29
HA004260000	70	73	M1010590000	54	13	M89105900A0	50	5
HA006000000	24	6	M1011590000	54	12	M89105900A0	60	3
HD00057000A	38	25	M1012592000	54	9·10	M90015900A0	60	1
HD002230000	10	30	M1012594000	54	9·10	M90025800A0	60	9
HD002230000	54	29	M1016580000	70	74	M90085800A0	60	4
HF001301000	54	20~23	M1022594000	56	2	M90105810A0	60	2
HF002900300	54	23	M1022594000	72	28	M90115900A0	54	28
HF0041080P0	54	20~23	M1030590000	54	36	M90135900A0	70	51
HK014820340	72	44	M1031590000	54	27	M90145800A0	60	16
HK026650080	50	19	M300258000B	50	8·9	M90175800A0	60	12~14
HK034610020	24	3	M300259400A	54	6~8	M90195800A0	6	34
HK034610020	28	61	M300259400B	54	6~8	M90205800A0	60	5·6
HK03461002D	30	13	M300259400C	54	6~8	M9020580AA0	60	5·6
HK034610040	64	54	M3003580000	54	24·25	M90215940A0	56	5
HK034610100	70	77	M300359000A	50	8·9	M90215940A0	72	31
HK034640000	24	4	M300451100A	54	24·25	M90225900A0	60	7·8
HK034640000	30	14	M8002430000	2	4	M90235900A0	60	7·8
HK034640000	64	57	M85105810A0	52	50	M90245800A0	60	12~14
HK034640000	70	78	M8510594AA0	54	1~3	M90255800A0	70	83
HK03464000A	28	62	M8510594BA0	54	1~3	M90285800A0	60	12~14
HK054250040	50	20	M8510594CA0	54	1~3	M90315800A0	70	63
HM000630010	52	48	M85205800A0	70	48	M90315900A0	60	10

# NUMERICAL INDEX OF PARTS

PART NO	PAGE	REF NO.	PART NO	PAGE	REF NO.	PART NO	PAGE	REF NO.
M90325800A0	72	42	NS6660430SP	30	36	SB31000080A	20	47~50
M90335800A0	72	43	PA060060100	68	10	SB31000080B	22	47~50
M90415900A0	58	4	PA100101900	68	9	SB31000080C	22	47~50
M90425900A0	58	5	PA1501515A0	24	19	SB31000080D	22	47~50
M90435900A0	58	6	PA1602006A0	42	35	SD0500803TP	30	47
M90435920A0	58	7	PA2501506A0	16	45	SD0530221SP	26	25
M90445920A0	58	2	PB000010000	70	87	SD0640321SP	24	21
M90475900A0	58	3	PC010519000	68	16	SD0640391TP	26	27
M964051000A	56	12	PC012401000	42	45	SD0640482SP	26	28
M964051000A	58	8	PF0552040B0	64	51	SD0640602SP	24	23
M964051000A	62	31	PH1000332SH	16	20	SD0650305TP	32	48
M964051000A	72	23	PJ030520001	64	52	SD0720321TP	26	26
MAO11532000	62	12	PJ032052503	16	44	SD0790311TP	32	49
MAT00616000	56	6	PJ046039001	68	17	SD0800321TH	18	62
MAT00616000	72	32	PJ046052503	42	36	SD0800321TH	20	33
MDP170B1800	12	53·57·60- ·61	PJ304040504	24	20	SD0800331TH	24	22
MDP170B1802	62	14·27·28	PJ304060001	14	7	SD0800331TH	54	32
MDP170B2300	12	53·57·60- ·61	PJ305065202	64	53	SD0800341SP	18	61
MDP170B2302	62	14·27·28	PJ309005203	64	49	SD0800431SP	16	31
MDP170B2500	12	53·57·60- ·61	PJ309520001	70	88	SD1100301TP	32	50
MDP170B2600	12	53·57·60- ·61	PS0400142KH	10	40	SK3311601SE	62	29
MDP170B2602	62	14·27·28	PV010011000	70	54	SK3311601SE	66	33
NM3034000SF	50	27	PV150209000	14	16	SK3382001SE	4	64
NM3040520SF	50	53	PV150209000	68	53	SK3382001SE	54	17
NM3040520SF	52	53	PV150209000	70	53	SK3382001SE	56	13
NM6040000SN	30	10	PV915005000	14	6	SK3382001SE	58	9
NM6050001SE	48	24	PX050003000	14	8	SK3382001SE	62	38
NM6050001SP	30	40	PX500014000	70	57	SK3382001SE	72	36
NM6060001SC	6	12	PX950009000	64	56	SK3482001SE	50	42
NM6060001SC	50	6	RC0150001KP	20	38	SK3482001SE	54	37
NM6060001SC	62	33	RC0560711KP	2	40	SK3482001SE	56	10
NM6080721SE	62	8	RC0740811KP	16	2	SK3482001SE	72	25
NM6080721SE	66	25	RC0841011KP	16	25	SK3513201SE	66	34
NM6120001SE	66	27	RC1411018KP	22	51	SL4030681SF	50	29
NM6540023SB	18	49	RE0300000K0	42	37	SL4030881SF	54	11
NS6110420SP	16	33	RE0400000K0	2	41	SL4030891SC	24	24
NS6110420SP	30	42	RE0500000K0	30	44	SL4030891SC	50	30
NS6110530SP	4	51	RE0500000K0	42	20	SL4031081SC	38	26
NS6120310SP	26	33	RE0600000K0	16	52	SL4031291SC	38	27
NS6120310SP	30	43	RE0600000K0	18	52	SL4040681SC	34	35
NS6160520SP	26	45	RO069180100	38	11	SL4040681SC	50	36
NS6660410SH	30	9	RO154240100	10	42	SL4040681SC	72	14
			SB110000900	38	44	SL4040881SF	50	31
			SB110001300	38	43	SL4040881SF	56	9
			SB115000200	20	37	SL4040881SF	70	80

# NUMERICAL INDEX OF PARTS

PART NO	PAGE	REF NO.	PART NO	PAGE	REF NO.	PART NO	PAGE	REF NO.
SL4040881SF	72	35	SM8061612TP	10	29	SS6110610TP	62	45
SL4041081SF	50	33	SM9061203SE	66	19	SS6110610TP	68	29
SL4041091SC	36	53	SM9061403CP	42	19	SS6110810TP	26	64
SL4041091SC	50	40	SM9082023SE	66	22	SS6110810TP	28	64
SL4041091SC	72	26	SS1060210TP	34	30	SS6111052TP	26	22
SL4041291SC	10	31	SS1060210TP	68	21	SS6111140SP	2	62
SL4041291SC	14	1	SS1060210TP	72	22	SS6111140SP	4	62
SL4041291SC	54	34	SS1110640TP	36	51	SS6111140SP	24	30
SL4051091SC	50	39	SS1110840SP	2	14	SS6111140SP	38	31
SL4051091SC	62	36	SS1110840SP	12	69	SS6111610SP	44	35
SL6052092TN	10	34	SS4090515SP	26	30	SS6120930SP	32	56
SL9082091SE	66	12	SS4090715SP	2	20	SS6120930SP	44	6
SL9082093SE	62	37	SS4091015SP	34	39	SS6151142TP	16	29
SM1040801SP	42	14	SS4091015SP	72	8	SS6151220SP	20	21
SM1044050SM	52	52	SS4110515SP	6	33	SS6151220SP	40	49
SM3065052TC	50	45	SS4110515SP	36	58	SS6151412TP	10	22
SM4021201SC	6	43	SS4110515SP	44	30	SS6151440SP	38	39
SM4031601SN	68	26	SS4110515SP	72	38	SS6151812TP	26	32
SM4031851SR	50	34	SS4110715SP	4	58	SS6681712TP	10	23
SM4040601SC	54	33	SS4110715SP	38	29	SS7060310SP	70	71
SM4040655SP	62	5	SS4110715SP	62	4	SS7080510TP	12	54
SM4051405SE	48	23	SS4110815SP	6	27	SS7090410SP	14	13
SM4060801SE	10	32	SS4110915SP	2	21	SS7090410SP	34	16
SM5030655SN	2	42	SS4111015SP	2	11	SS7091110TP	16	15
SM6040602TP	30	37	SS4111415SP	42	21	SS7110410SP	38	33
SM6040802TP	42	15	SS4150715SP	6	23	SS7110510SP	70	58
SM6040802TP	68	19	SS4150715SP	42	17	SS7110710SP	34	56
SM6041202TP	42	16	SS4150715SP	44	23	SS7110710SP	36	56
SM6050802TP	24	25	SS4151215SP	2	15	SS7110730SP	6	6
SM6053502TP	18	53	SS4151215SP	14	3	SS7110740TP	32	54
SM6060802TP	42	18	SS4151215SP	22	53	SS7110740TP	34	42
SM6067552TP	8	48	SS6060210SP	68	22	SS7110740TP	72	18
SM6067552TP	62	32	SS6090612TP	6	2	SS7110810SP	16	19
SM6850802TN	68	23	SS6090630TP	24	26	SS7110840SP	6	45
SM8040412TP	28	65	SS6090670TP	12	50	SS7110840SP	10	35
SM8040600SP	12	56	SS6092120SP	44	24	SS7110840SP	16	46
SM8040802TP	2	43	SS6110420TP	38	46	SS7110840SP	20	42
SM8050502TP	2	44	SS6110430TP	34	43	SS7110840SP	24	31
SM8050812TP	16	43	SS6110430TP	72	19	SS7110840SP	32	55
SM8053002TP	30	19	SS6110480SP	38	42	SS7110840SP	42	23
SM8060612TP	10	28	SS6110480SP	44	41	SS7110840SP	44	14
SM8060612TP	38	50	SS6110560TP	20	30	SS7110840SP	62	43
SM8060612TP	40	50	SS6110610TP	6	18	SS7111120TP	26	31
SM8060812TP	10	46	SS6110610TP	32	57	SS7111810TP	68	25
SM8060812TP	38	9	SS6110610TP	38	34	SS7150910TP	18	60

## NUMERICAL INDEX OF PARTS

PART NO	PAGE	REF NO.	PART NO	PAGE	REF NO.
SS7151120SP	10	25	WP0451026SH	32	53
SS7161040SP	6	35	WP0480856SP	42	25
SS7661540SP	22	54	WP0482086SD	26	8
SS8090610SP	26	58	WP0501016SD	30	45
SS8090610SP	28	58	WP0520656SA	62	44
SS8110510SP	26	37	WP0520656SA	68	30
SS8150822TP	20	10	WP0531001SC	48	22
SS8150822TP	32	58	WP0553216SD	30	21
SS8660330SP	10	8	WP0600816SP	16	28
SS8660410SP	20	19	WP0612066SP	16	34
SS8660512TP	10	24	WP0621016SD	42	27
SS8660522TP	20	12	WP0621026SP	18	55
SS8660612TP	16	9	WP0641600SC	32	51
SS8660612TP	38	23	WP0641601SD	20	31
SS8660810TP	10	12	WP0651001SC	50	46
SS8661012TP	32	59	WP0651056SD	26	34
SS9111010SP	14	14	WP0651646SC	8	49
ST40316110R	54	14	WP0651646SC	62	34
ST5041051SN	70	75	WP0671016SE	66	20
SV4031006SR	54	16	WP0722316SH	26	47
TA0550604R0	44	37	WP0871602SE	62	7
TA0750704R0	6	29	WP0871602SE	66	23
TA1050504R0	4	59	WP0951016SP	16	41
TA1050504R0	6	30	WP1302501SE	66	28
TA1250406R0	2	18	WP1612616SE	48	15
TA1250406R0	6	31	WS0310002KR	68	27
TA1270502R0	6	13	WS0310702KS	50	35
TA2100904R0	6	25	WS0410002KP	42	29
WP0250501SC	68	24	WS0510002KN	48	21
WP0280500SC	70	70	WS0610002KN	12	67
WP0330516SC	2	45	WS0610002KN	50	21
WP0371016SD	16	14	WS0621210KR	66	21
WP0371016SD	24	27	WS0861410KR	66	24
WP0371016SD	34	38	WS1253010KN	66	29
WP0371016SD	72	7			
WP0430801SC	54	35			
WP0430801SE	68	20			
WP0450000SD	30	12			
WP0450000SD	42	24			
WP0450000SD	44	43			
WP0450000SD	70	59			
WP0450801SD	62	6			
WP0450846SP	34	55			
WP0450846SP	36	55			
WP0450846SP	72	17			