

MODEL : AMS-221EN/IP-420

List No : 1543-06

PARTS LIST

Published:02/15/2019

CONTENTS

FRAME & MISCELLANEOUS COVER COMPONENTS (1)	1
FRAME & MISCELLANEOUS COVER COMPONENTS (2)	5
FRAME & MISCELLANEOUS COVER COMPONENTS (3)	9
FRAME & MISCELLANEOUS COVER COMPONENTS (4)	13
MAIN SHAFT & NEEDLE BAR COMPONENTS	15
PRESSER MECHANISM & PRESSER VARIABLE COMPONENTS (1)	19
PRESSER MECHANISM & PRESSER VARIABLE COMPONENTS (2)	23
SHUTTLE DRIVER SHAFT COMPONENTS	27
WIPER MECHANISM COMPONENTS	31
TENSION RELEASE & THREAD TENSION COMPONENTS	33
THREAD TRIMMER MECHANISM COMPONENTS	37
THREAD CLAMP COMPONENTS	41
X-Y COMPONENTS (1)	45
X-Y COMPONENTS (2)	49
CLOTH FEED MECHANISM COMPONENTS (1)	53
CLOTH FEED MECHANISM COMPONENTS (2)	57
TABLE COMPONENTS	59
PNEUMATIC COMPONENTS	63
THREAD STAND COMPONENTS	65
OPERATION PANEL COMPONENTS	67
CONTROL BOX COMPONENTS	69
WIRING DIAGRAM	73
PEDAL COMPONENTS	77
ACCESSORIE PART COMPONENTS	79
OPTIONAL PARTS	81
LIST FOR INFORMATION OF CHANGE	83
HOW TO MAKE USE OF THIS PARTS LIST	84

FRAME & MISCELLANEOUS COVER COMPONENTS (1)

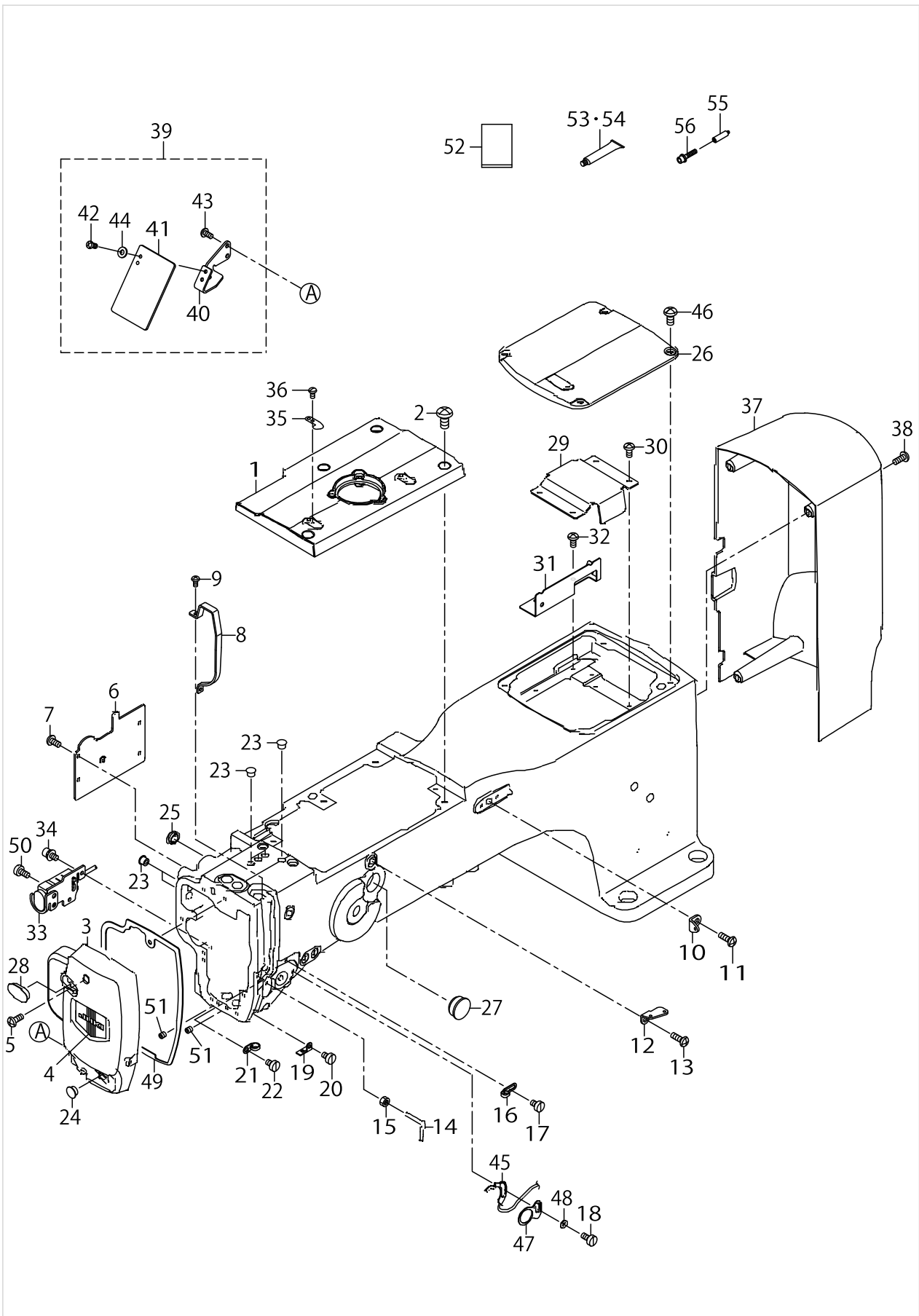

FRAME & MISCELLANEOUS COVER COMPONENTS (1)

No.	Parts No.	Parts name	Remarks	Level	Cons	Qty
1	40032158	TOP_COVER_FRONT				1
2	SM4061255SP	SCREW M6 L=12				4
3	40026979	FACE_COVER				1
4	22902506	FACE PLATE				1
5	SM4041055SP	SCREW				2
6	40024999	PRESSER_COVER				1
7	SM4040855SP	SCREW				4
8	40030828	THREAD_TAKE_UP_LEVER_COVER				1
9	SM4030601SN	SCREW M3X6				2
10	40010414	THREAD_GUIDE_NO.1				1
11	SM4061255SP	SCREW M6 L=12				1
12	26211904	THREAD GUIDE PLATE				1
13	SM4061255SP	SCREW M6 L=12				1
14	40025414	L_SHAPED_THREAD_GUIDE				1
15	NM6040000SN	NUT M4				1
16	22920508	ARM THREAD GUIDE A				1
17	SM6040650TP	SCREW				1
18	SM6040860TP	SCREW M4 L=8				1
19	B1129210000	FRAME THREAD GUIDE (B)				1
20	SM6040650TP	SCREW				1
21	13705108	TAKE-UP THREAD GUIDE B				1
22	SM6040650TP	SCREW				1
23	TA0850604R0	RUBBER PLUG				6
24	TA1050504R0	RUBBER PLUG				2
25	TA1250406R0	RUBBER PLUG D=12.5 L=4				1
26	40032159	TOP_COVER_REAR				1
27	TA2351004R0	RUBBER PLUG				1
28	40028877	FACE_COVER_CAP				1
29	40010405	CRANK_ROD_COVER				1
30	SM4040855SP	SCREW				4
31	40084115	GREASE PLATE				1
32	SM4040855SP	SCREW				2
33	40040242	STOP SW ASM				1
34	SL6040892TN	BOLT				1
35	10502300	THREAD CUTTER				1
36	SM4030601SN	SCREW M3X6				1
37	40027971	MOTOR_COVER				1
38	SM4041055SP	SCREW				4
39	40006484	SAFETY PLATE COMPL.				1
40	40051987	SAFETY PLATE BASE		*		1
41	B3120372000	SAFETY PLATE		*		1
42	SM4040655SP	SCREW M4 L=6		*		2
43	SM4040855SP	SCREW		*		2
44	WP0450801SD	WASHER 4.5X10X0.8		*		2
45	40040225	THB SENSOR CABLE ASM				1
46	SM4051055SP	SCREW				4
47	40028834	GUIDE_PLATE				1

FRAME & MISCELLANEOUS COVER COMPONENTS (1)

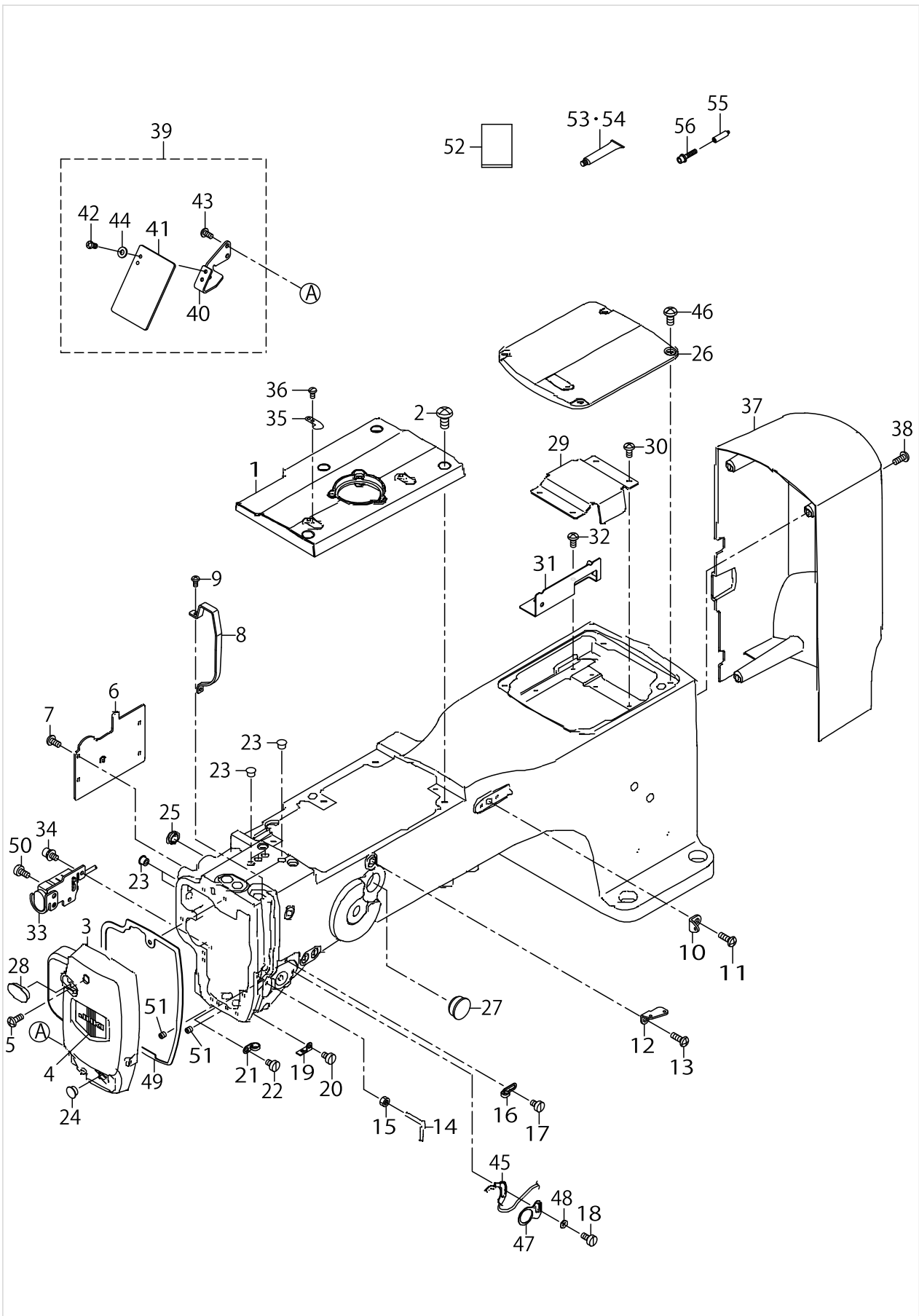

FRAME & MISCELLANEOUS COVER COMPONENTS (1)

No.	Parts No.	Parts name	Remarks	Level	Cons	Qty
48	40028835	BUSHING				1
49	40050509	FACE PLATE CUSHION				1
50	SM6040860TP	SCREW M4 L=8				1
51	SM8040412TP	SET SCREW M4 L=4				2
52	40031336	FLAT_BAG				1
53	40013640	JUKI_GREASE_B_TUBE			☆	1
54	40006323	JUKI GREASE A TUBE				1
55	40036110	GREASE_JOINT_B				1
56	SL6084092TN	BOLT				1

FRAME & MISCELLANEOUS COVER COMPONENTS (2)

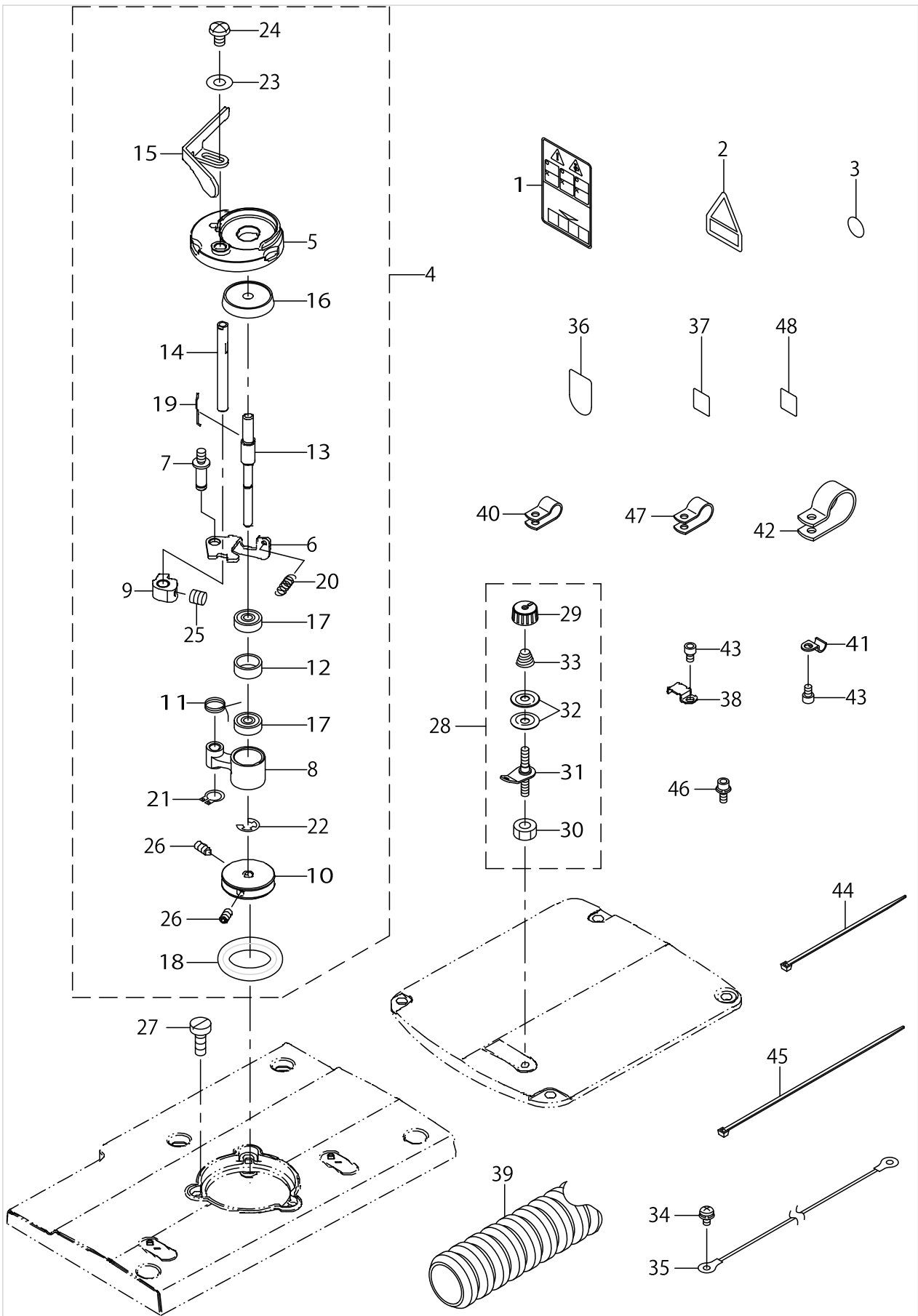

FRAME & MISCELLANEOUS COVER COMPONENTS (2)

No.	Parts No.	Parts name	Remarks	Level	Cons	Qty
1	CM301200001	SAFETY LABEL_S				1
2	CM300200003	ATTENTION LABEL				1
3	22901805	GROUND MARK				1
4	40028338	BOBBIN_WINDER_UNIT				1
5	26260109	BTW_BASE		*		1
6	26260208	BTW_CAM_PLATE		*		1
7	26260307	BTW_BASE_SHAFT		*		1
8	26260406	BTW_SHAFT_BASE		*		1
9	26260505	BTW_CAM_LEVER		*		1
10	26260604	BTW_WHEEL		*		1
11	26260703	BTW_TORSION_SPRING		*		1
12	26260802	BTW_BEARING_SPACER		*		1
13	40023865	BTW_SHAFT		*		1
14	40023866	BTW_LEVER_SHAFT		*		1
15	40030829	BTW_LEVER		*		1
16	26261206	BTW_SPACER		*		1
17	26261305	BTW_BEARING		*		2
18	26261503	BTW_WHEEL_RUBBER		*		1
19	26261602	BOBBIN_SPRING		*		1
20	26261701	BTW_SPRING		*		1
21	RC0560711KP	RETAINING RING		*		1
22	RE0400000K0	E-RING 4		*		1
23	WP0450826SC	WASHER 4.5X10X0.8		*		1
24	SM5040655SN	SCREW		*		1
25	SM8050502TP	SCREW M5 L=5		*		1
26	SM8040802TP	SCREW M4X8		*		2
27	SM6041150TP	SCREW				3
28	14113468	BOBBIN THREAD TENSION ASM.				1
29	11072402	THREAD TENSION NUT		*		1
30	NS6110310SP	NUT 11/64-40		*		1
31	14113450	BOBBIN THREAD TENSION ROD ASM.		*		1
32	B3126012000	THREAD TENSION DISK		*		2
33	D7133555B00	CONNECTING ROD SPRING		*		1
34	SL4040891SC	SCREW M4 L=8				1
35	40005712	EARTH CODE ASM				1
36	CM100100001	OIL INJECTION PROHIBITION LABEL				1
37	CM600100101	WEEE MARK LABEL S	FOR JE			4
38	B3509210000	OIL TUBE HOLDER C				6
39	HX00307000E	TUBE				0.45
40	HX00150000C	CABLE BAND				1
41	B3538112000	OIL RETURN TUBE HOLDER				3
42	HX00150000K	CABLE CLIP				1
43	SM6040602TP	SCREW M4 L=6				9
44	EA9500B0100	CABLE BAND				6
45	EA9500B0200	CABLE BAND 150				6
46	SL6041092TN	SCREW				2
47	HX00150000D	CABLE CLIP				5

FRAME & MISCELLANEOUS COVER COMPONENTS (2)

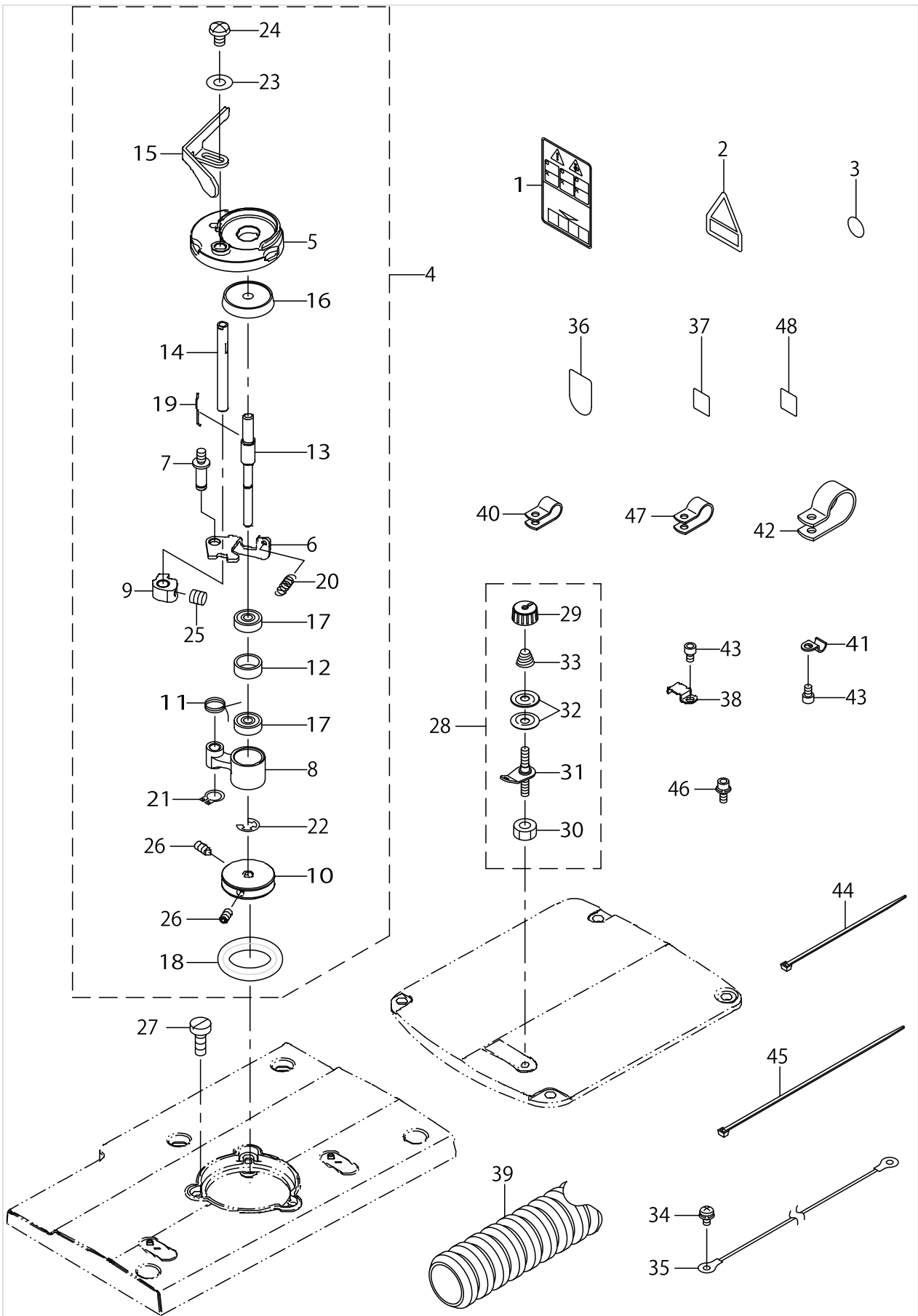

FRAME & MISCELLANEOUS COVER COMPONENTS (2)

No.	Parts No.	Parts name	Remarks	Level	Cons	Qty
48	40150131	EAC_MARK_LABEL_S	FOR JE			1

FRAME & MISCELLANEOUS COVER COMPONENTS (3)

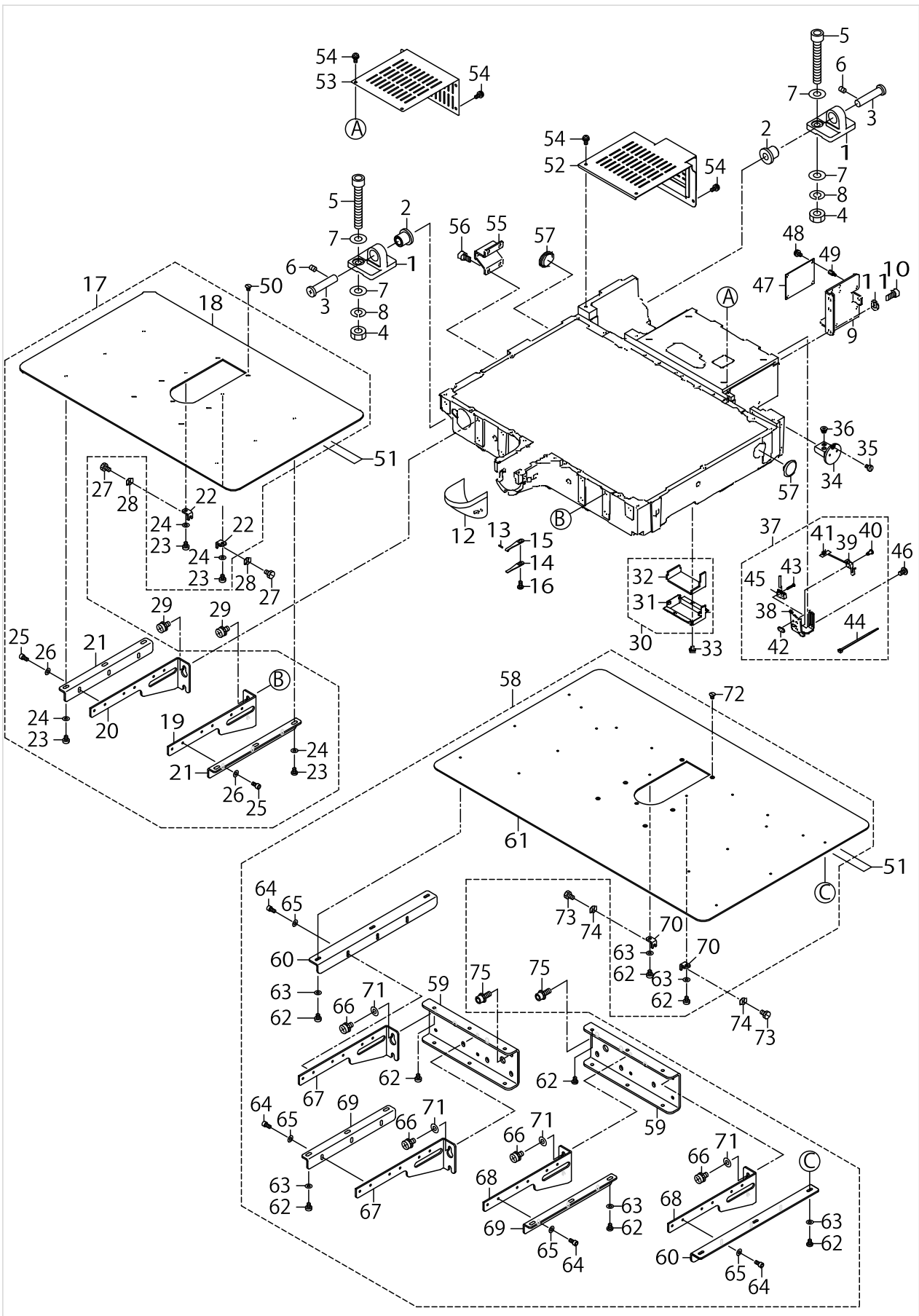

FRAME & MISCELLANEOUS COVER COMPONENTS (3)

No.	Parts No.	Parts name	Remarks	Level	Cons	Qty
1	B1111215000	BED HINGE				2
2	B1115215000	BED HINGE RUBBER PAD				2
3	B2529232000	FEED ACROSS REGULATOR SHAFT				2
4	NM6100001SD	NUT M10				4
5	SM6107002TP	SCREW M10 L=70				4
6	SM8060812TP	SCREW M6 L=8				4
7	WP1052001SC	WASHER 10.5X21X2				8
8	WS1020002KN	SPRING WASHER M10				4
9	40024997	LIFTER_BASE				1
10	SM6061202TP	SCREW M6 L=12				2
11	WP0651001SC	WASHER				2
12	13816855	CYLINDER ARM CAP				1
13	31262801	PIN				1
14	26221200	HOOK COVER PRESSER SPRING B				1
15	26221101	HOOK COVER PRESSER SPRING A				1
16	SM5040855SN	SCREW				1
17	40090330	NEEDLE_PLATE_SUPPORT_COVER_ASM	FOR AMS-221EN-2516			1
18	40032173	NEEDLE_PLATE_SUPPORT_COVER		*		1
19	40039546	COVER_SUPPORT_R		*		1
20	40039547	COVER_SUPPORT_L		*		1
21	B1132223C00	COVER BASE		*		2
22	40086367	COVER SUPPORT B		*		2
23	SM6450610TP	SCREW		*		8
24	WP0450801SP	WASHER		*		8
25	SM6040802TP	SCREW M4X0.7 L=8		*		6
26	WP0450801SP	WASHER		*		6
27	SM9050850SP	SCREW				2
28	WP0520656SA	WASHER 5.2X9.5X0.6				2
29	SL9061291SE	WASHER HEXAGONAL BOLT M6 L=12	FOR AMS-221EN-2516			4
30	40026829	GEAR_COVER_ASM.				1
31	40026830	GEAR_COVER		*		1
32	40026831	GEAR_COVER_FELT		*		1
33	SL4040681SC	COMBINATION SCREW M4X8				2
34	40006836	OIL TANK ASM.				1
35	SM6040650TP	SCREW				1
36	40006840	RUBBER BUSH				2
37	40033182	SAFETY_SW_ASM				1
38	40033183	SAFETY_SW_BASE		*		1
39	23638109	SAFETY SWITCH ARM		*		1
40	40006497	SAFETY_SW_ARM_SHAFT		*		1
41	23638208	SAFETY SWITCH SPRING		*		1
42	23638406	SAFETY SWITCH NUT		*		1
43	SM4021201SC	SCREW M2 L=12		*		2
44	EA9500B0100	CABLE BAND		*		1
45	40029633	SAFETY SW CORD ASM		*		1
46	SM4050855SP	SCREW				1
47	40040230	INT PCB ASM				1

FRAME & MISCELLANEOUS COVER COMPONENTS (3)

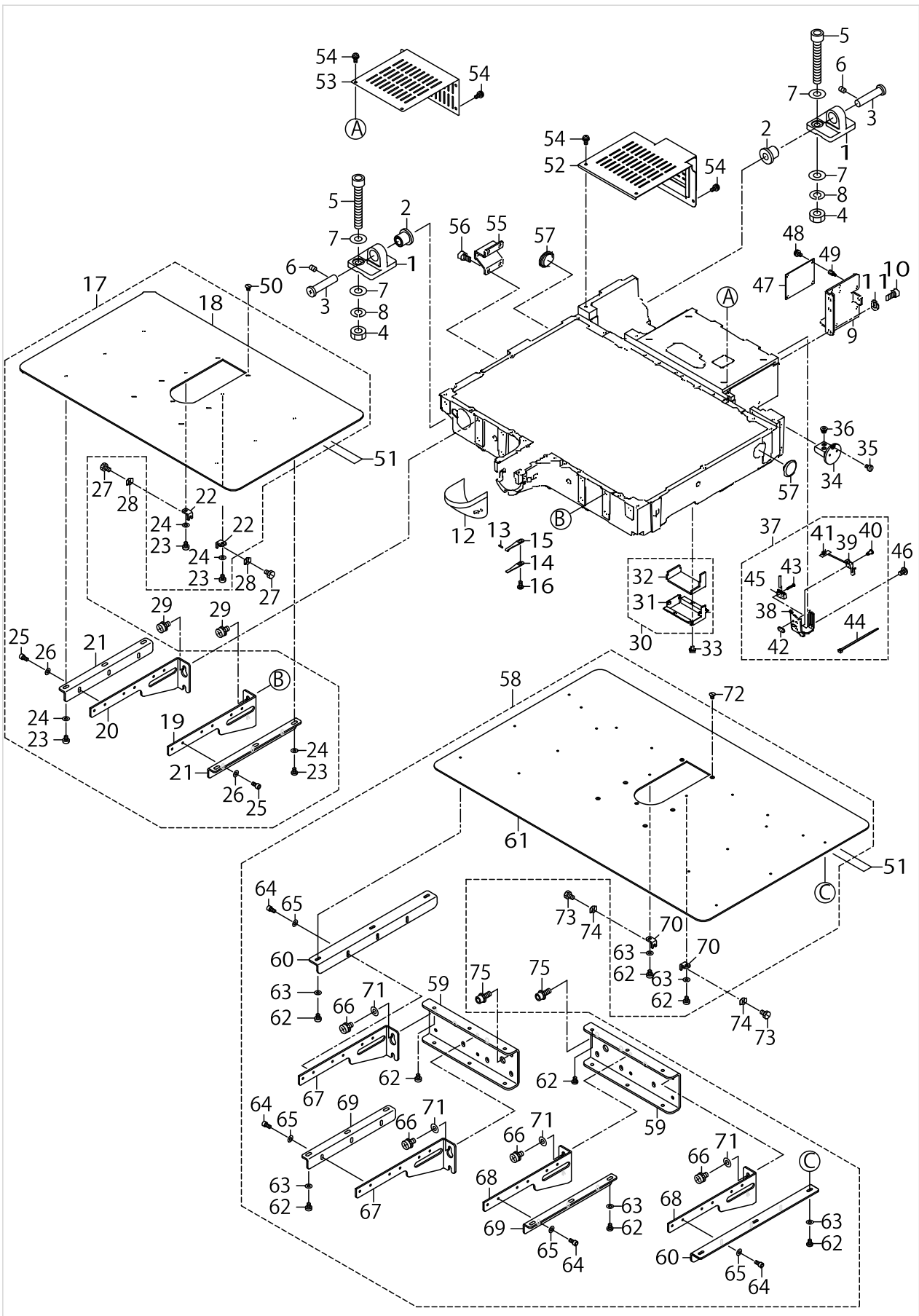

FRAME & MISCELLANEOUS COVER COMPONENTS (3)

No.	Parts No.	Parts name	Remarks	Level	Cons	Qty
48	SL4040891SC	SCREW M4 L=8				4
49	HX003390000	STUD				4
50	SM1040650TP	SCREW				2
51	40051501	TAPE				1
52	40057380	BED_COVER_LEFT_ASM.	FOR AMS-221EN-2516			1
53	40032161	BED_COVER_RIGHT				1
54	SL4041091SC	SCREW M4 L=10				8
55	B1116215000	FRAME SUPPORT				1
56	SM6061002TP	SCREW M6 L=10				4
57	B8267180000	RUBBER PLUG				2
58	40090331	NEEDLE_PLATE_SUPPORT_COVER_ASM				1
59	40051499	COVER_SUPPORT_BASE		*		2
60	40051502	COVER_BASE		*		2
61	40032174	NEEDLE_PLATE_SUPPORT_COVER		*		1
62	SM6450610TP	SCREW		*		18
63	WP0450801SP	WASHER		*		12
64	SM6040802TP	SCREW M4X0.7 L=8		*		12
65	WP0450801SP	WASHER		*		12
66	SL9061291SE	WASHER HEXAGONAL BOLT M6 L=12		*		8
67	40039547	COVER_SUPPORT_L		*		2
68	40039546	COVER_SUPPORT_R		*		2
69	B1132223C00	COVER BASE		*		2
70	40086367	COVER SUPPORT B		*		2
71	WP0612056SD	WASHER 6.1X18.5X2		*		8
72	SM1040650TP	SCREW				2
73	SM9050850SP	SCREW				2
74	WP0520656SA	WASHER 5.2X9.5X0.6				2
75	SL6061692TN	BOLT				10

FRAME & MISCELLANEOUS COVER COMPONENTS (4)

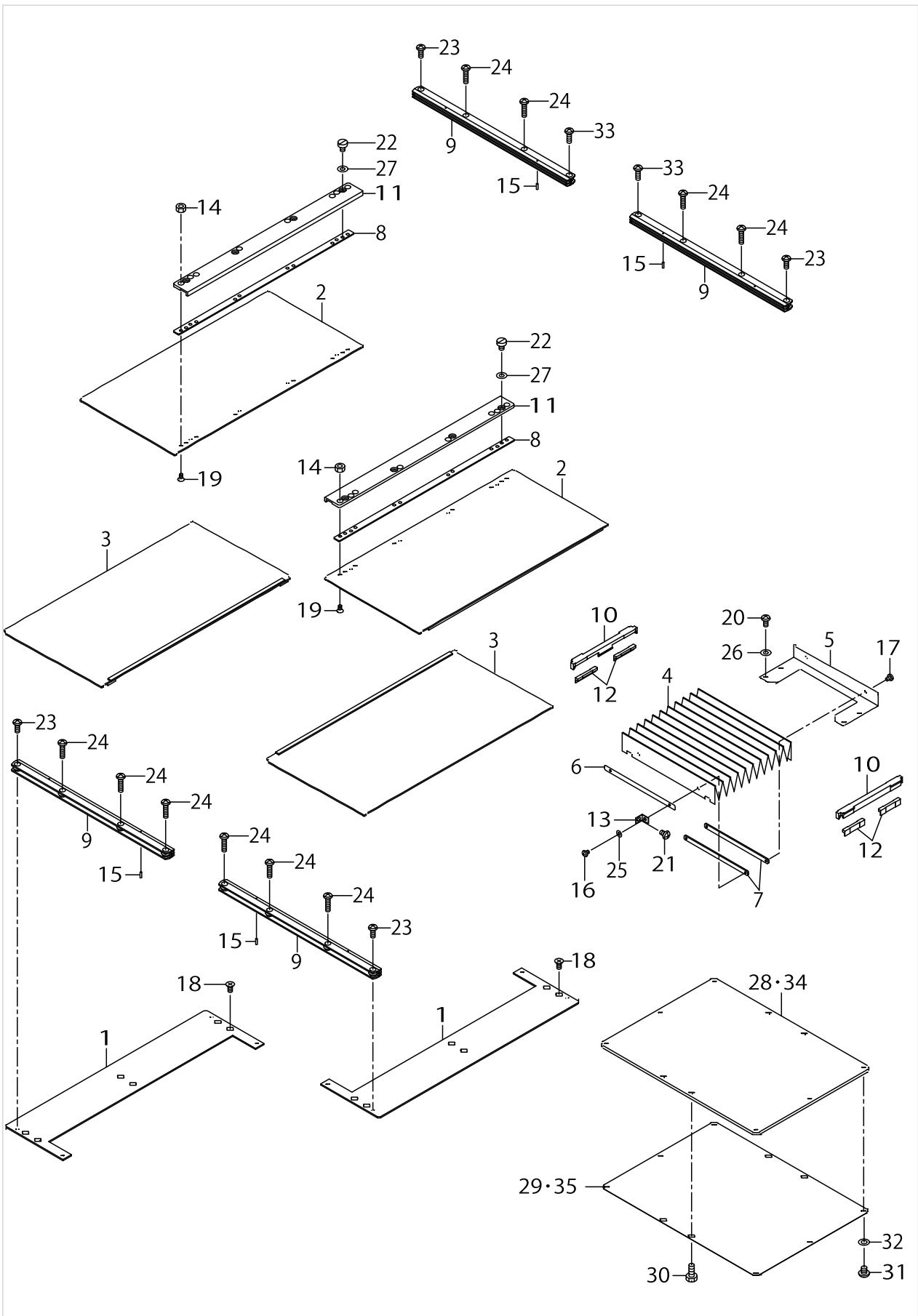

FRAME & MISCELLANEOUS COVER COMPONENTS (4)

No.	Parts No.	Parts name	Remarks	Level	Cons	Qty
1	40032162	FEED_BASE_COVER				2
2	40032168	X_FEED_UPPER_COVER_ASM				2
3	40032163	X_FEED_LOWER_COVER_ASM				2
4	40035705	FEED COVER				1
5	40033186	FEED_COVER_STAY				1
6	B1155221D00	FEED COVER FIX PLATE				1
7	B1156221D00	FEED COVER FIX PLATE B				2
8	40032167	FEED_COVER_RALL_STOPPER_PLATE				2
9	B1181221D00	FEED BASE SUPPORT COVER RAIL X				4
10	B1182221D00	Y GUIDE RAIL BRACKET				2
11	B1183221D00	FEED BASE SUPPORT COVER RAIL Y				2
12	B1193221D00	Y GUIDE RAIL BUSH				4
13	B1157215000	MOVEMENT COVER PLATE				2
14	NM6030003SC	NUT M3				8
15	PS0150065KP	SPRING PIN 1.5X6				4
16	SM4030401SC	SCREW M3X0.5 L=4				2
17	SM7030450SC	SCREW M3X0.5 L=3.5				2
18	SM1040801SP	SCREW M4X0.7 L=8				6
19	SM1030601SP	SCREW M3 L=6				8
20	SM4040855SP	SCREW				4
21	SM4040655SP	SCREW M4 L=6				2
22	SM6040650TP	SCREW				8
23	SM4041055SP	SCREW				4
24	SM4041655SP	SCREW M4 L=16				10
25	WP0330501SB	WASHER M3				2
26	WP0450801SD	WASHER 4.5X10X0.8				4
27	WP0450801SD	WASHER 4.5X10X0.8				8
28	40032176	PRESSER_PLATE	FOR AMS-221EN-2516			1
29	B1504221D00	PRESSER PLATE SHEET	FOR AMS-221EN-2516			1
30	SM9051203CP	SCREW M5 L=12				4
31	SM4050655SP	SCREW M5 L=6				6
32	WP0531000SD	WASHER M5				6
33	SM4041255SP	SCREW M4 L=12				2
34	40032177	PRESSER_PLATE				1
35	40032178	PRESSER_PLATE_SHEET				1

MAIN SHAFT & NEEDLE BAR COMPONENTS

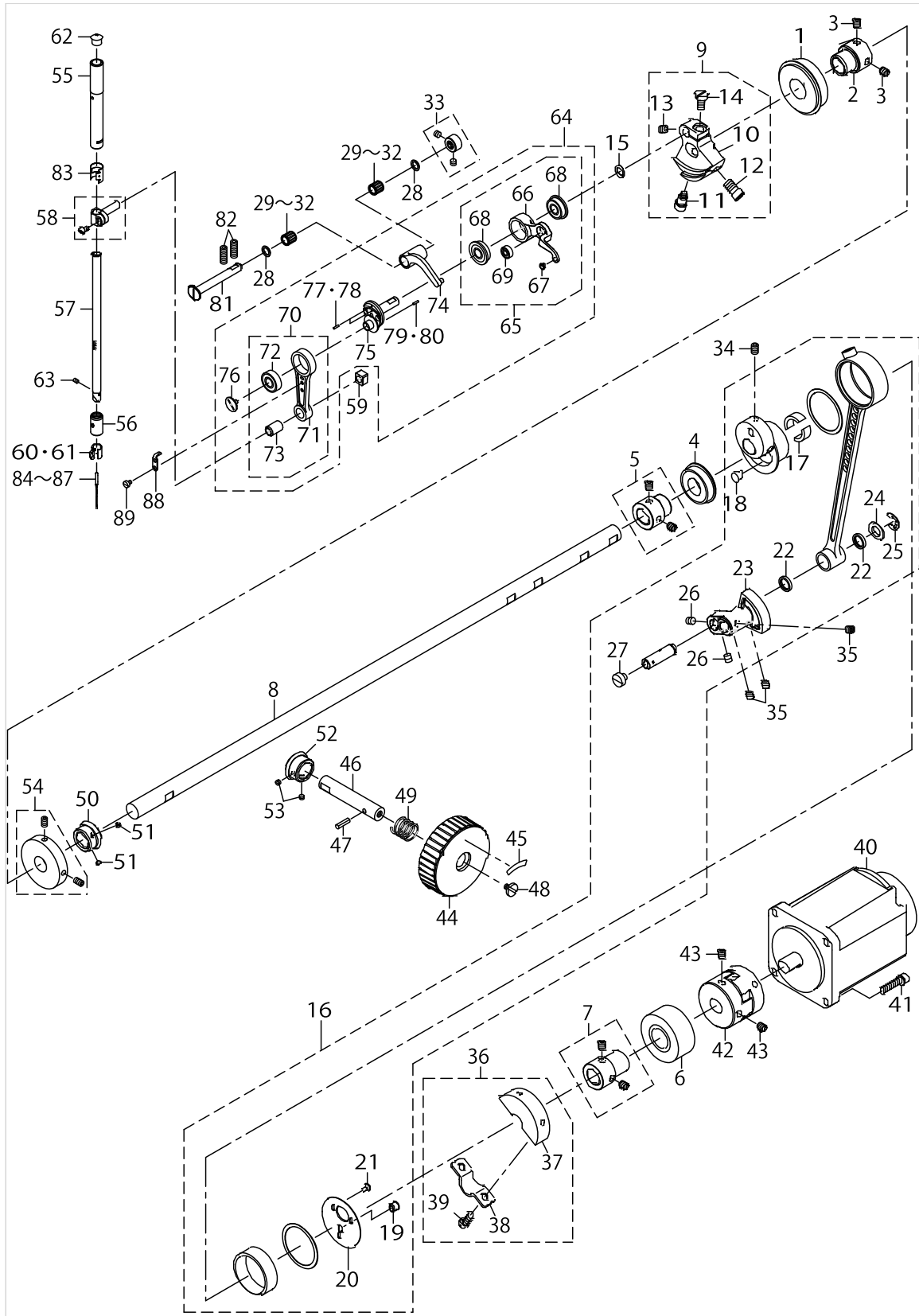

MAIN SHAFT & NEEDLE BAR COMPONENTS

No.	Parts No.	Parts name	Remarks	Level	Cons	Qty
1	SB12000900	BEARING				1
2	23604200	MAIN SHAFT BEARING SUPPORT				1
3	SM8060812TP	SCREW M6 L=8				2
4	SB120001800	BEARING				1
5	40010415	BEARING_BUSH_A_ASM.				1
6	SB120001700	BEARING				1
7	40010418	BEARING_BUSH_B_ASM.				1
8	40032175	MAIN_SHAFT				1
9	40010422	COUNTER_WEIGHT_ASM.				1
10	40010423	COUNTER_WEIGHT		*		1
11	40010424	COUNTER_WEIGHT_SCREW_A		*		1
12	40010425	COUNTER_WEIGHT_SCREW_B		*		1
13	40010426	COUNTER_WEIGHT_SCREW_C		*		1
14	40010427	COUNTER_WEIGHT_SCREW_D		*		1
15	WP0820516SP	WASHER 11.6X8.2X0.6				1
16	40089367	CRANK_ROD_ALL_ASM				1
17	40006555	UNDER CAM FELT		*		2
18	TA0670604R0	PLUG D=6.7 L=6		*		1
19	TA0670604R0	PLUG D=6.7 L=6		*		1
20	40010421	CRANK_ROD_SUPPORT_PLATE		*		1
21	SM1030601SP	SCREW M3 L=6		*		3
22	10108009	OIL SEAL		*		2
23	40006561	OSCILLATOR		*		1
24	40026818	WASHER		*		1
25	RE0800000K0	E-SHAPED SNAP RING (8MM)		*		1
26	SM8480652TP	SCREW		*		2
27	SM6060550TP	SCREW M6 L=4.5		*		1
28	22891204	BEARING SUPPORT				2
29	SB30700020A	BEARING	SELECTIVE PARTS			2
30	SB30700020B	BEARING	SELECTIVE PARTS			2
31	SB30700020C	BEARING	SELECTIVE PARTS			2
32	SB30700020D	BEARING	SELECTIVE PARTS			2
33	40010434	THRUST_COLLAR_ASM.				1
34	SM8060812TP	SCREW M6 L=8				2
35	SM8480652TP	SCREW				3
36	40010437	CRANK_BALANCER_ASM.				1
37	40010438	CRANK_BALANCER		*		1
38	40010439	CRANK_BALANCER_FIX_PLATE		*		1
39	40010440	CRANK_BALANCER_FIX_PLATE_SCREW		*		2
40	40052937	550W_SERVO_MOTOR				1
41	SL6052592TN	BOLT				4
42	23604309	COUPLING				1
43	SM8060812TP	SCREW M6 L=8				4
44	B1212210D00	PULLEY				1
45	B1144210000	REVOLVING DIRECTION LABEL				1
46	40044053	PULLEY SHAFT				1
47	PS0400142KH	SPRING PIN 4X14				1

MAIN SHAFT & NEEDLE BAR COMPONENTS

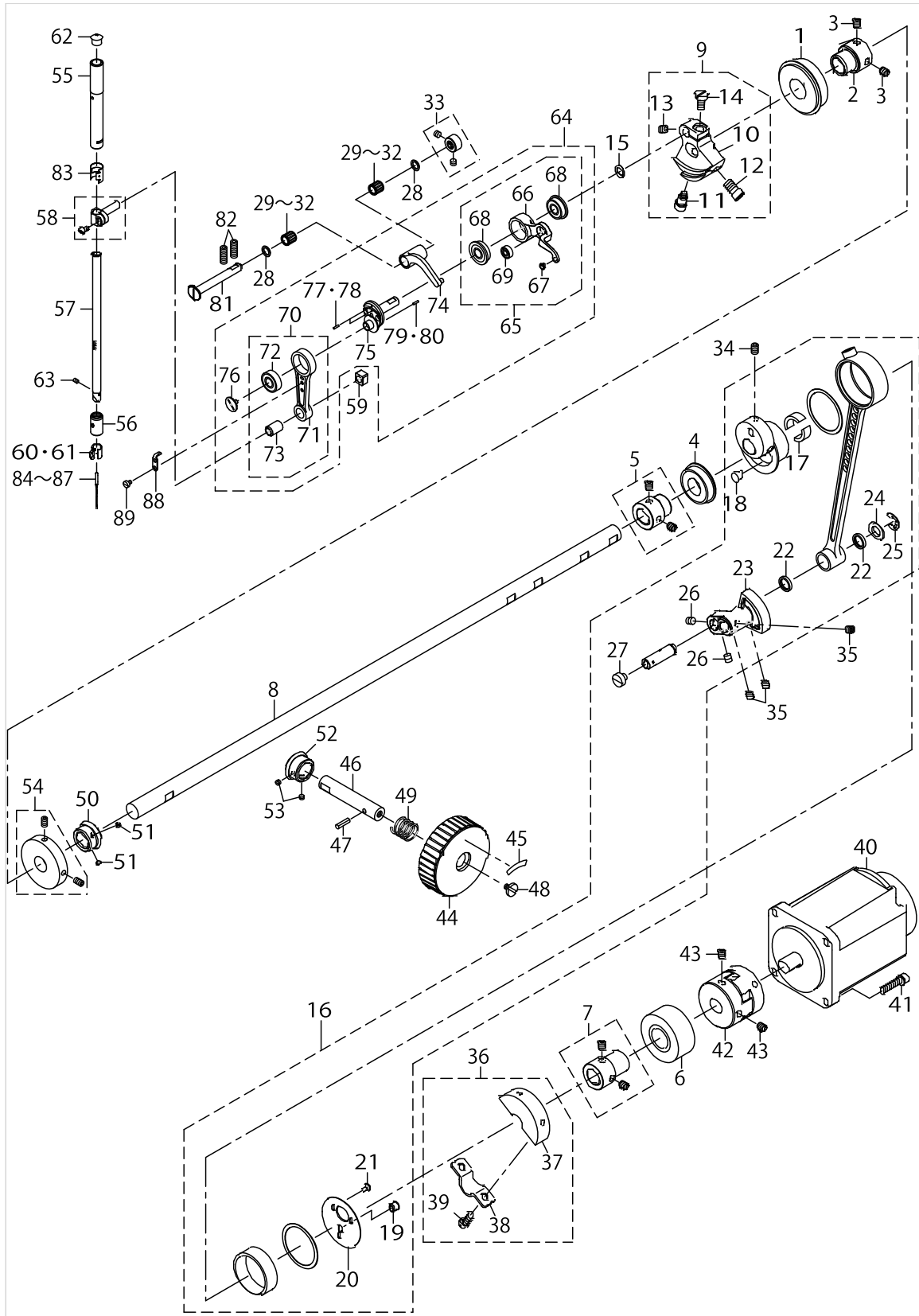

MAIN SHAFT & NEEDLE BAR COMPONENTS

No.	Parts No.	Parts name	Remarks	Level	Cons	Qty
48	A123050000A	HANDWHEEL SETSCREW				1
49	GAF01007000	SPRING				1
50	40006515	GEAR_A				1
51	SM8040310SS	SCREW M4 L=3				2
52	40006516	GEAR_B				1
53	SM8040310SS	SCREW M4 L=3				2
54	40010533	BTW_DRIVING_WHEEL_ASM.				1
55	40077604	NEEDLE_ROD_METAL				1
56	40077605	NEEDLE_ROD_LOWER_METAL				1
57	40026882	NEEDLE_BAR				1
58	B14115520A0	NEEDLE BAR CONNECTING ASM.				1
59	B1414555000	SLIDE BLOCK				1
60	B1405210000	THREAD GUIDE A				1
61	40026884	NEEDLE_BAR_SHREAD_GUIDE_H				1
62	22901409	NEEDLE BAR UPPER BUSH CAP				1
63	SM8030412TP	SCREW			☆	1
64	40078382	THREAD_TAKE_UP_COMPL				1
65	40006530	THREAD_TAKE_UP_LEVER_ASM.		*		1
66	40006531	THREAD_TAKE_UP_LEVER		*		1
67	B1908505000	THREAD PASS BUSH		*		1
68	SB108002200	BEARING		*		2
69	SB104001600	BEARING		*		1
70	40078106	NEEDLE_BAR_CRANK_ROD_ALL_ASM		*		1
71	40078088	NEEDLE_BAR_CRANK_ROD		*		1
72	SB108002300	BEARING		*		1
73	22891006	NEEDLE BAR CRANK ROD BUSH		*		1
74	40006532	THREAD_TAKE_UP_CRANK		*		1
75	40078083	NEEDLE_ROD_CRANK		*		1
76	B1903552000	LEFT SCREW		*		1
77	40078135	PIN	SELECTIVE PARTS	*		1
78	40096186	PIN	SELECTIVE PARTS	*		1
79	B1705850000	STOPPER PIN	SELECTIVE PARTS	*		1
80	40096209	PIN	SELECTIVE PARTS	*		1
81	40078079	THREAD_TAKE_UP_CRANK_SHAFT				1
82	SM8061612TP	SCREW M6X16				2
83	40078160	NEEDLE_ROD_METAL_GREASE_COVER				1
84	MDP500B1400	NEEDLE DPX5 #14			☆	1
85	MDP170B1800	NEEDLE DPX17 #18			☆	1
86	MC200501000	NEEDLE #100			☆	1
87	MC372001100	NEEDLE 135X17 #110			☆	1
88	40078107	KNIFE				1
89	SM6030450TP	SCREW M3 L=4				2

PRESSER MECHANISM & PRESSER VARIABLE COMPONENTS (1)

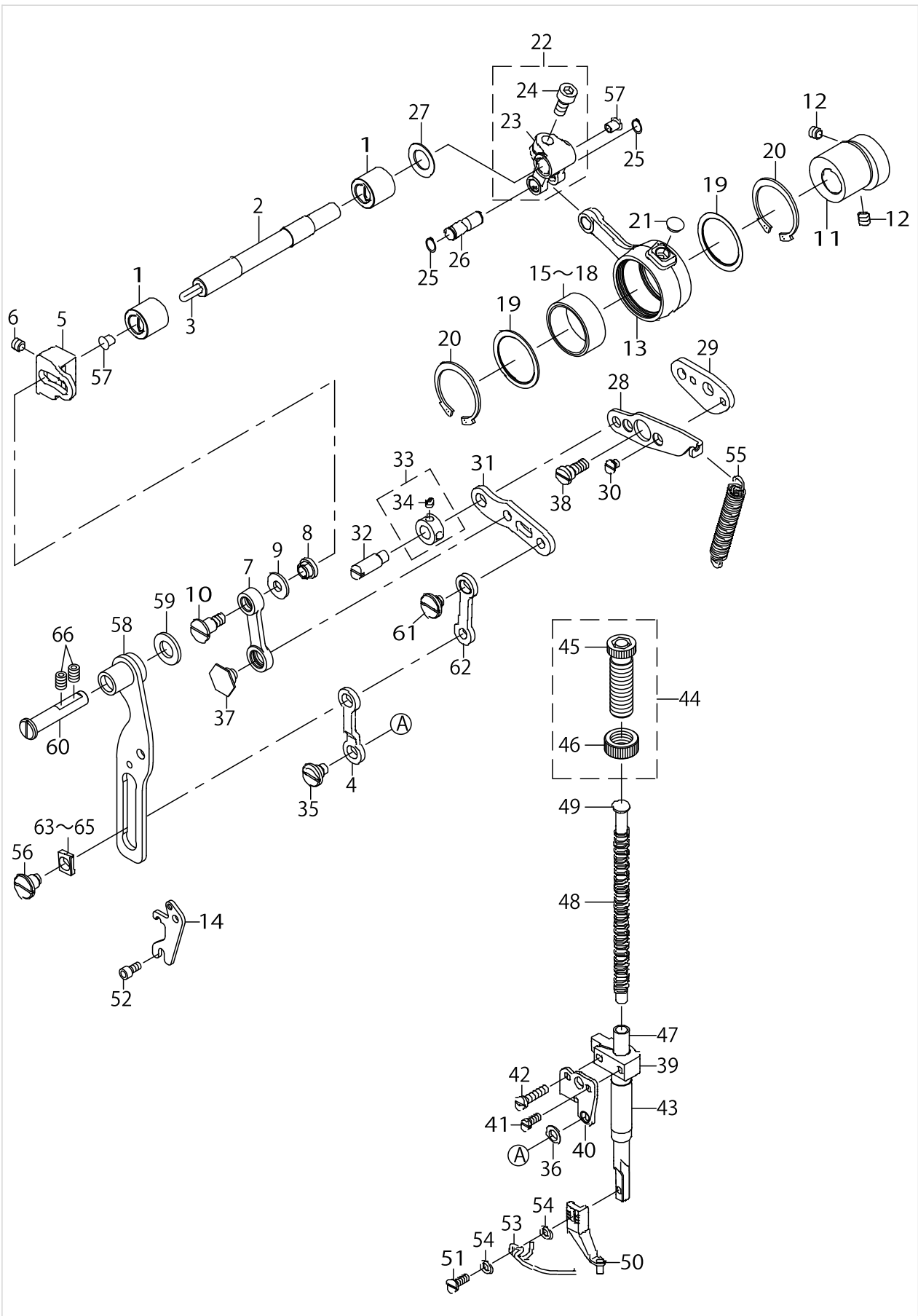

PRESSER MECHANISM & PRESSER VARIABLE COMPONENTS (1)

No.	Parts No.	Parts name	Remarks	Level	Cons	Qty
1	40025431	BUSHING				2
2	40025427	INTERMEDIATE_PRESSER_SHAFT				1
3	CQ303000000	OIL WICK				0.18
4	40030617	INTERMEDIATE_PRESSER_LINK_D				1
5	40025012	ADJUSTING_ARM				1
6	SM8060812TP	SCREW M6 L=8				1
7	40068835	INTERMEDIATE_PRESSURE_LINK				1
8	40025415	ADJUSTING_NUT				1
9	WP0611626SP	WASHER 15X6X1.6				1
10	SD0800746TP	SHOULDER SCREW				1
11	40025428	ECCENTRIC_CAM				1
12	SM8060812TP	SCREW M6 L=8				2
13	40025011	CRANK_CONNECTING_ROD				1
14	40068833	POSITIONING_LINK_SPRING_HOOK				1
15	B1636581A00	NEEDLE BEARING A	SELECTIVE PARTS			1
16	B1636581B00	NEEDLE BEARING B	SELECTIVE PARTS			1
17	B1636581C00	NEEDLE BEARING	SELECTIVE PARTS			1
18	B1636581D00	NEEDLE BEARING	SELECTIVE PARTS			1
19	40012965	BEARING_SUPPORT_PLATE				2
20	RC3781518KP	RETAINING RING				2
21	TA0750404R0	PLUG D=7.5 L=3.5				1
22	13122452	FEED BRANCH CRANK ASM.				1
23	13122403	FEED BRANCH CRANK		*		1
24	SM6061402TP	SCREW M6 L=14		*		1
25	RC0650811KP	RETAINING RING				2
26	40025429	ROD_CONNECTING_SHAFT				1
27	WP1221016SP	WASHER				1
28	40068834	POSITIONING_LINK				1
29	40024988	POSITIONING_LINK_B				1
30	SS1110640TP	SCREW 11/64-40 L=5.5				2
31	40030620	INTERMEDIATE_PRESSER_LINK_B				1
32	B1408180000	HINGE SCREW				1
33	CS079073ASH	THRUST COLLAR ASM.				1
34	SS8110410TP	SCREW 11/64-40 L=3.5		*		2
35	SD0800386TP	SHOULDER SCREW D=8 H=3.75				1
36	40029419	LINK_CONNECTING_PLATE_WASHER				1
37	SD1000506TP	SHOULDER SCREW D=10 H=4.95				1
38	SD0800408TP	SHOULDER SCREW				1
39	23610108	PRESSER BAR GUIDE BRACKET				1
40	40024991	LINK_CONNECTING_PLATE				1
41	SS6090910SP	SCREW 9/64-40 L=9				1
42	SS7111810TP	SCREW 11/64-40 L=18				1
43	40078133	PRESSER_BUSHING				1
44	22907554	PRESSER SPRING REG NUT ASM.				1
45	22907505	PRESSER SPRING REGULATOR		*		1
46	22907604	PRESSER SPRING REGULATOR NUT		*		1
47	40030623	INTERMEDIATE_PRESSER_BAR				1

PRESSER MECHANISM & PRESSER VARIABLE COMPONENTS (1)

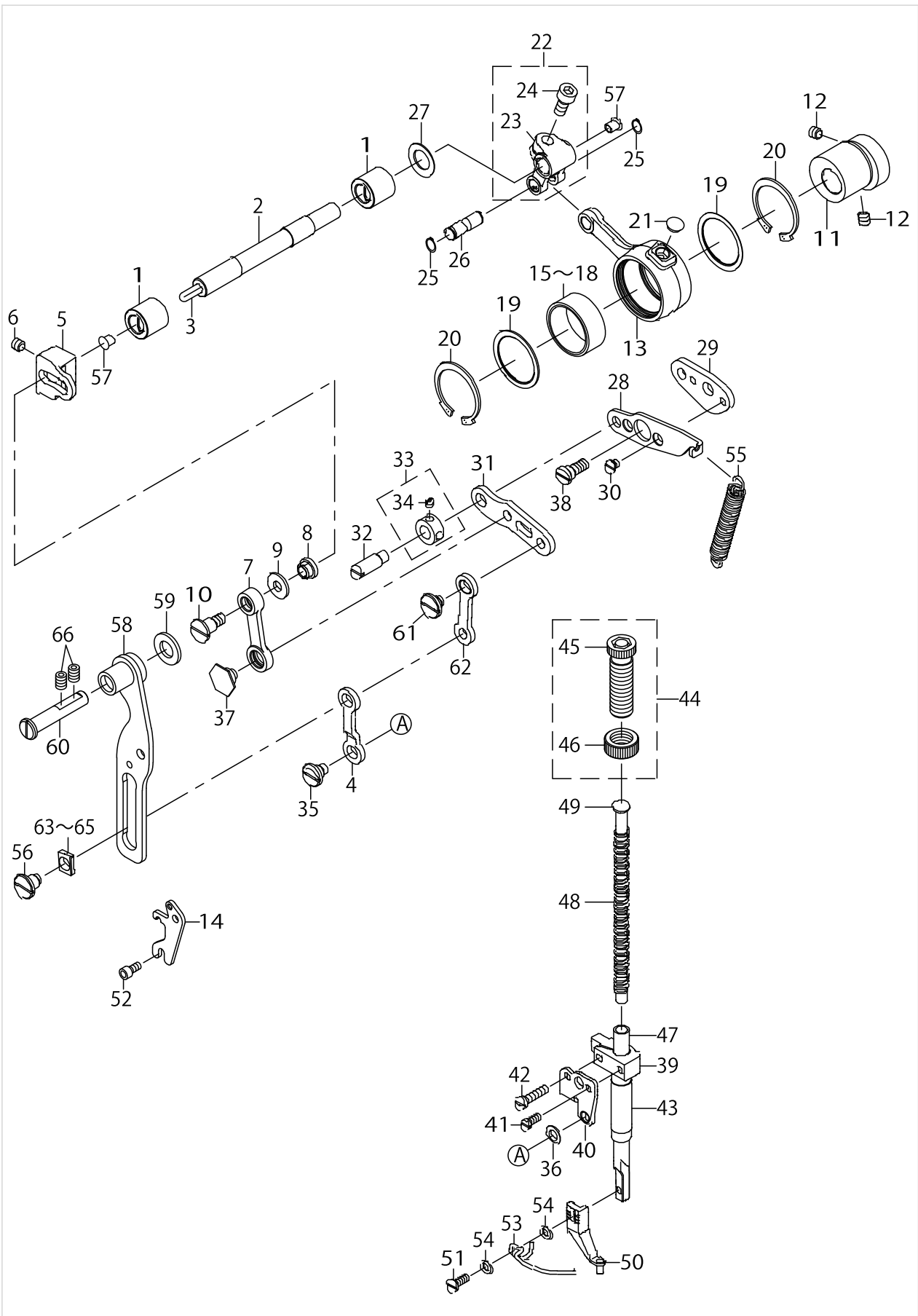

PRESSER MECHANISM & PRESSER VARIABLE COMPONENTS (1)

No.	Parts No.	Parts name	Remarks	Level	Cons	Qty
48	B161121000A	INNER PRESSER SPRING				1
49	40023631	PRESSER GUIDE BAR				1
50	40023632	INTERMEDIATE PRESSER A			☆	1
51	SM7751160TP	SCREW				1
52	SM6040802TP	SCREW M4X0.7 L=8				2
53	B1634210D00	FINGER GUARD				1
54	WP0430800SC	WASHER M4				2
55	40030621	INTERMEDIATE_PRESSER_SPRING B				1
56	SD0800656TP	SHOULDER SCREW				1
57	TA0550604R0	RUBBER PLUG				1
58	40096092	PRESSURE_VARIABLE_PLATE_ASM_BL				1
59	40078113	COLLAR				1
60	40023624	THREAD_TRIMMER_SHAFT				1
61	SD0800336TP	SHOULDER SCREW				1
62	40030616	INTERMEDIATE_PRESSER_LINK_C				1
63	40030628	SLIDE_BLOCK_A	SELECTIVE PARTS			1
64	40030629	SLIDE_BLOCK_B	SELECTIVE PARTS			1
65	40030630	SLIDE_BLOCK_C	SELECTIVE PARTS			1
66	SM8060812TP	SCREW M6 L=8				2

PRESSER MECHANISM & PRESSER VARIABLE COMPONENTS (2)

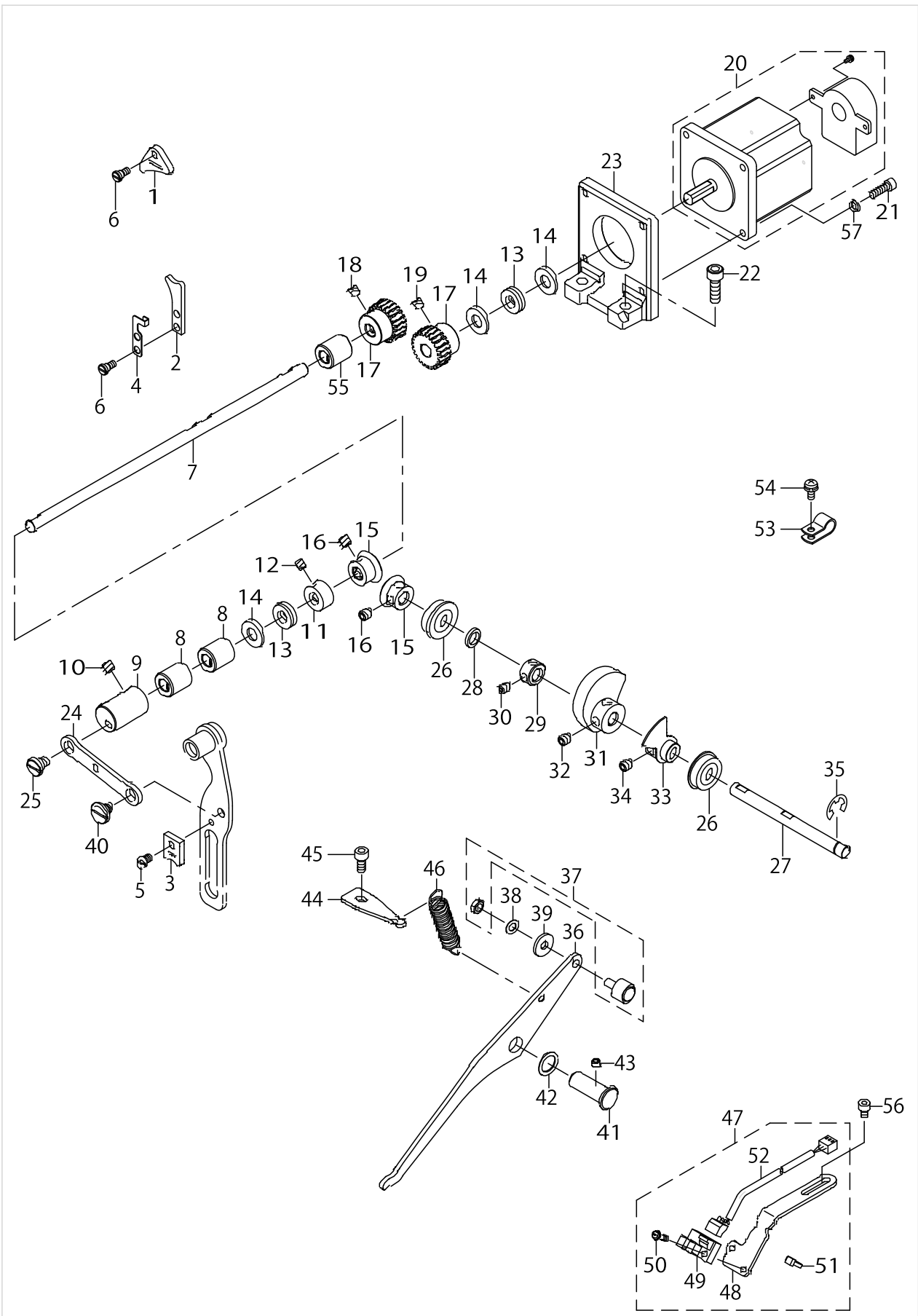

PRESSER MECHANISM & PRESSER VARIABLE COMPONENTS (2)

No.	Parts No.	Parts name	Remarks	Level	Cons	Qty
1	40030625	FACE_FELT_A				1
2	40030626	FACE_FELT_B				1
3	40030627	FACE_FELT_C				1
4	40026817	FACE_FELT_B_SUPPORT				1
5	40029420	FELT_SCREW_C				1
6	40032483	FELT_SCREW_AB				3
7	40032179	PRESSER_VARIABLE_SHAFT				1
8	40025423	BUSHING B				2
9	40026819	PRESSER_VARIABLE_ARM				1
10	SM8480652TP	SCREW				2
11	CS0800881TP	THRUST COLLAR				1
12	SM8050412TP	SCREW M5 L=4				2
13	SB408000100	BEARING				2
14	WP0850002SP	WASHER 8.5X18X1.6				3
15	40030615	PRESSER_LIFT_GEAR				2
16	SM8060812TP	SCREW M6 L=8				4
17	40032180	PRESSER_MOTOR_GEAR_A				2
18	SM8060812TP	SCREW M6 L=8				2
19	SM8060602TP	SCREW M6X6				2
20	40102213	ENCODER MOTOR ASM				1
21	SM6041402TP	SCREW M4 L=14				4
22	SM6061802TP	SCREW M6 L=18				2
23	40032181	PRESSER_MOTOR_BRACKET				1
24	40024989	PRESSER_VARIABLE_LINK				1
25	SD0800337TP	SHOULDER SCREW				1
26	SB108000500	RADIAL BEARING				2
27	40025426	PRESSER_LIFT_SHAFT				1
28	WZ0850302K0	WAVED WASHER 8.5X12.5X0.3				1
29	CS0800881TP	THRUST COLLAR				1
30	SM8050412TP	SCREW M5 L=4				2
31	40025016	LIFTING_CAM				1
32	SM8060812TP	SCREW M6 L=8				2
33	40025418	SENSOR_SLIT_ASM				1
34	SM8060812TP	SCREW M6 L=8				2
35	RE0700000K0	E-RING 7				1
36	40025030	LIFTING_LINK				1
37	40027870	CAM FOLLOWER				1
38	WP0520656SA	WASHER 5.2X9.5X0.6				1
39	WP0522016SH	WASHER				1
40	SD0800387TP	SHOULDER SCREW D=8 H=3.75				1
41	B1641562000	FEED REGULATING ARM SHAFT				1
42	26226001	WASHER				1
43	SM8050412TP	SCREW M5 L=4				1
44	40025420	LIFTER_LINK_SPRING_HOOK				1
45	SM6050802TP	SCREW M5X0.8 L=8				1
46	40003970	TENSION RELEASE RETURN				1
47	40073081	SENSER_INSTALLING_BASE_ASM.				1

PRESSER MECHANISM & PRESSER VARIABLE COMPONENTS (2)

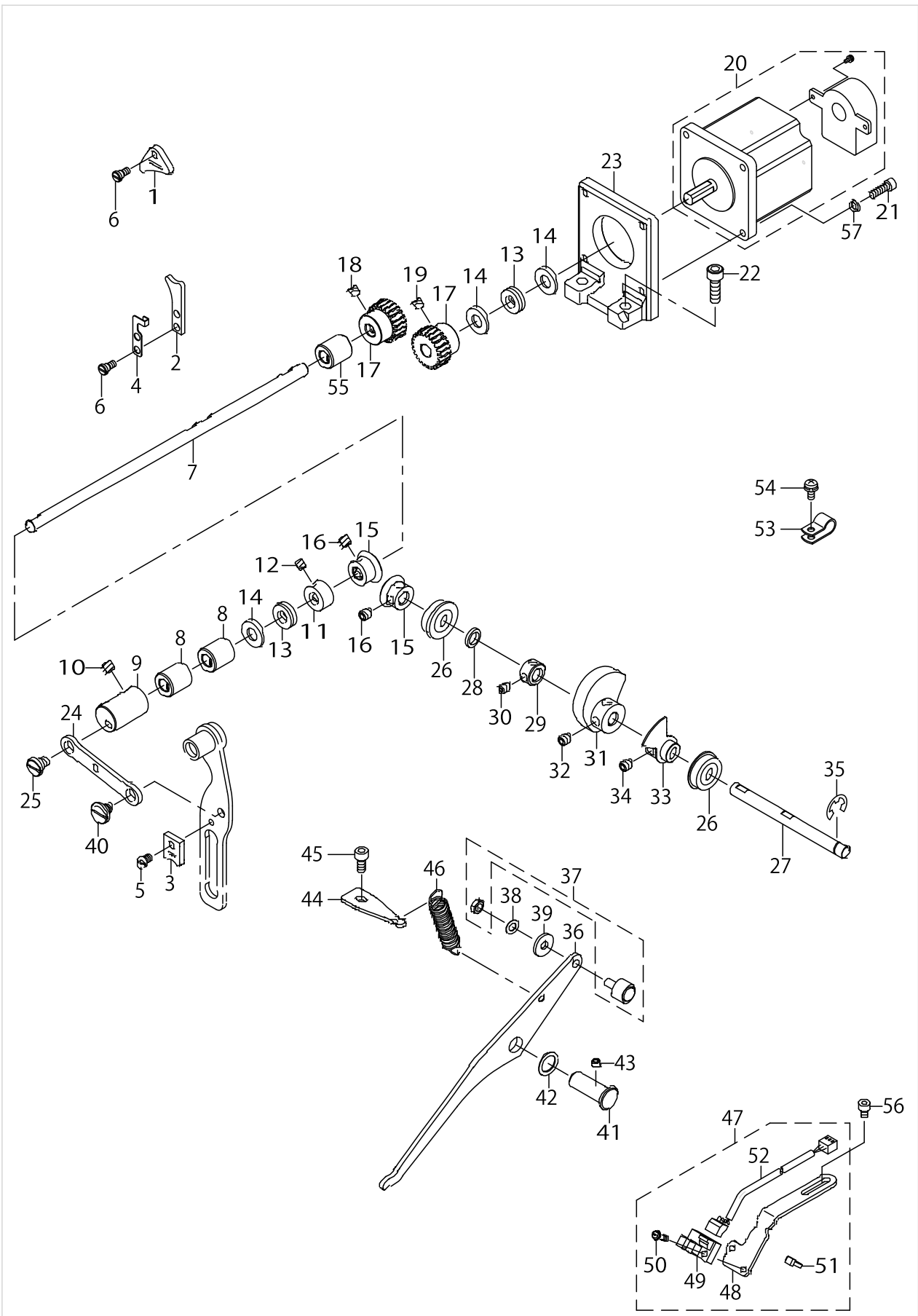

PRESSER MECHANISM & PRESSER VARIABLE COMPONENTS (2)

No.	Parts No.	Parts name	Remarks	Level	Cons	Qty
48	40025419	SENSOR_INSTALLING_BASE		*		1
49	HD00057000A	PHOTO SENSOR		*		1
50	SL4031091SC	SCREW M3X10		*		1
51	EA9500B0100	CABLE BAND		*		2
52	40040240	IP SENSOR CABLE ASM		*		1
53	HX00150000D	CABLE CLIP				2
54	SL4040891SC	SCREW M4 L=8				2
55	40043321	BUSHING_C				1
56	SM6040602TP	SCREW M4 L=6				2
57	WP0450846SP	WASHER				4

SHUTTLE DRIVER SHAFT COMPONENTS

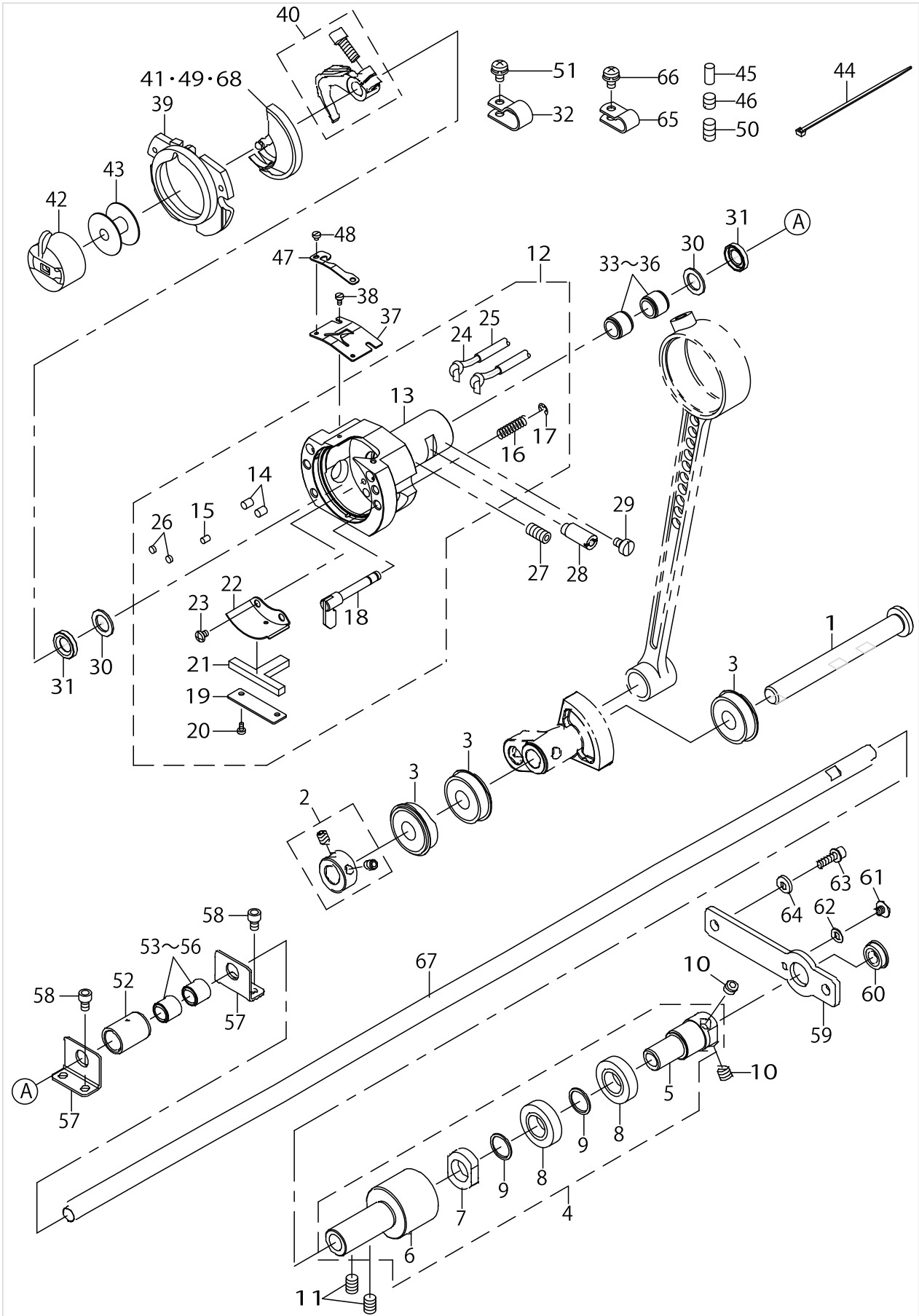

SHUTTLE DRIVER SHAFT COMPONENTS

No.	Parts No.	Parts name	Remarks	Level	Cons	Qty
1	40043869	OSCILLATOR_SHAFT				1
2	40010464	THRUST_COLLAR_ASM.				1
3	SB110002400	BEARING				3
4	40072009	LOWEW_SHAFT_GEAR_ASM				1
5	40006567	LOWER_SHAFT_GEAR		*		1
6	40006569	LOWER_SHAFT_REAR_METAL		*		1
7	40024063	NUT		*		1
8	SB112001700	BEARING		*		2
9	40006317	LOWER SHAFT GEAR RING		*		2
10	SM8060812TP	SCREW M6 L=8				2
11	SM8060812TP	SCREW M6 L=8				2
12	40034846	SHUTTLE_ASM				1
13	40089365	SHUTTLE		*		1
14	B1820210D00	SHUTTLE OIL FELT A		*		2
15	B1821210D00	SHUTTLE OIL FELT B		*		1
16	B1822215P00	INNER HOOK PRESSER SPRING		*		2
17	RE0300000K0	E-RING 3		*		2
18	26501858	INNER-HOOK-PRESSER COMPL.		*		2
19	14104004	ONCE THROUGH OIL FELT PRESSER		*		1
20	SM6020460TP	SCREW		*		2
21	14103907	SHUTTLE ONCE THROUGH OIL FELT		*		1
22	40006577	SHUTTLE_LUBRICATING_PLATE		*		1
23	SM4030455SP	SCREW		*		2
24	CQ200000000	OIL WICK		*		5.7
25	23630007	TUBE		*		2.22
26	13529607	SHUTTLE PACKING		*		2
27	SM8061212TP	SCREW M6X12				1
28	40010471	SHUTTLE_RACE_ADJUSTING_SHAFT				1
29	SM6040650TP	SCREW				1
30	40010472	SHUTTLE_BEARING_RING				2
31	40006576	SHUTTLE_OIL_SEAL				2
32	HX00150000D	CABLE CLIP				1
33	SB30800100A	BEARING	SELECTIVE PARTS			2
34	SB30800100B	BEARING	SELECTIVE PARTS			2
35	SB30800100C	BEARING	SELECTIVE PARTS			2
36	SB30800100D	BEARING	SELECTIVE PARTS			2
37	40036117	SHUTTLE UPPER SPRING				1
38	SM6020460TP	SCREW				2
39	14103352	INNER HOOK PRESSER ASM. B				1
40	40014963	SHUTTLE DRIVER ASM.				1
41	40061991	SHUTTLE(H)			☆	1
42	B1828210DAA	BOBBIN CASE ASM.			☆	1
43	B1806210D00	BOBBIN			☆	1
44	EA9500B0100	CABLE BAND				2
45	40006578	OIL_WICK_PRESSER				1
46	SM8060610TP	SCREW				1
47	40036118	LOWER THREAD HOLDER				1

SHUTTLE DRIVER SHAFT COMPONENTS

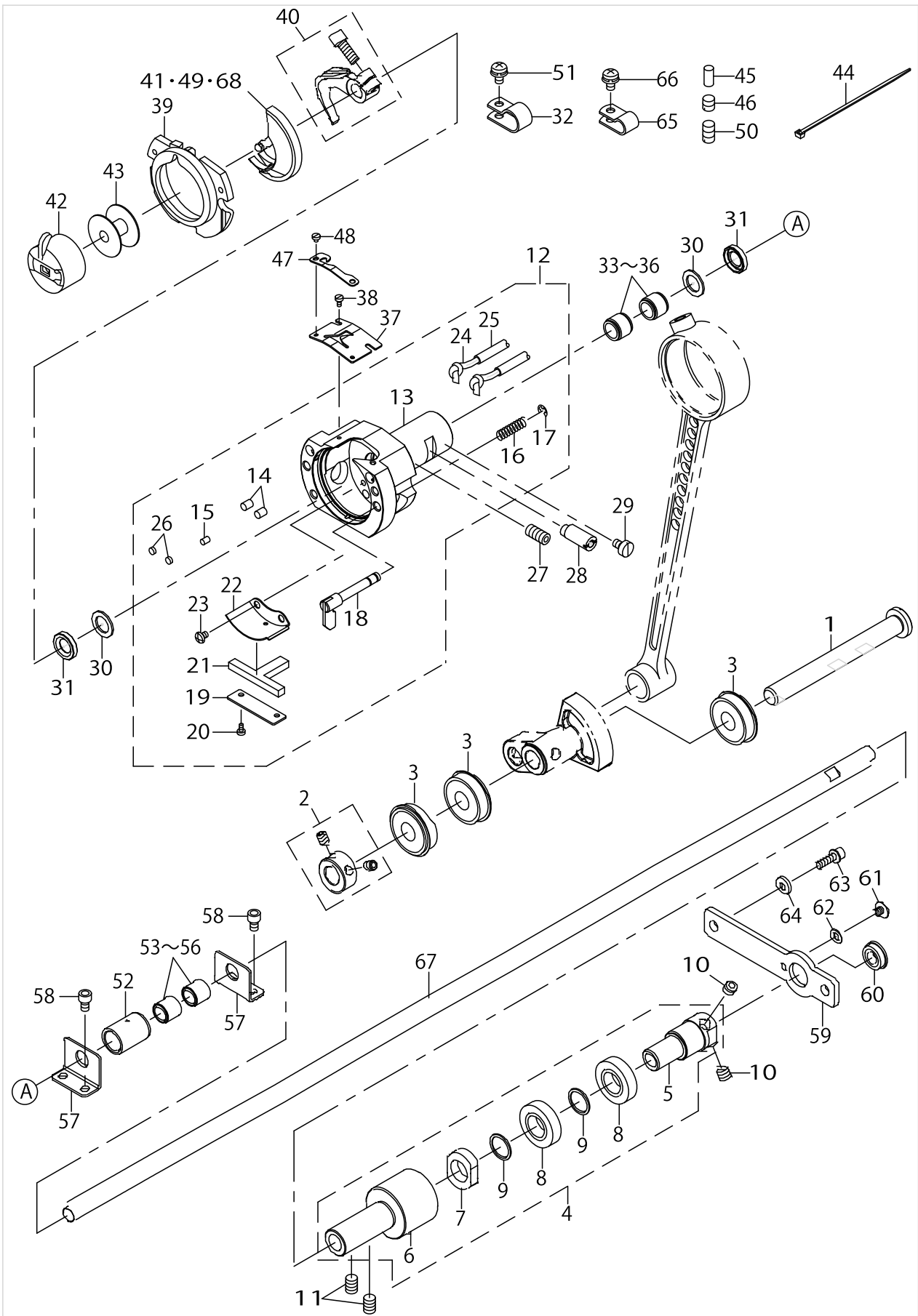

SHUTTLE DRIVER SHAFT COMPONENTS

No.	Parts No.	Parts name	Remarks	Level	Cons	Qty
48	SM6020250TP	SCREW				2
49	40014964	SHUTTLE			☆	1
50	SM8061050TP	SCREW				1
51	SL4040891SC	SCREW M4 L=8				1
52	B1847221D00	LOWER SHAFT MIDDLE METAL				1
53	B1411804A00	BEARING (A)	SELECTIVE PARTS			2
54	B1411804B00	NEEDLE DRIVING LEVER BEARING B	SELECTIVE PARTS			2
55	B1411804C00	NEEDLE DRIVING LEVER BEARING C	SELECTIVE PARTS			2
56	B1411804D00	BEARING (D)	SELECTIVE PARTS			2
57	40032185	LOWER_SHAFT_NEEDLE_SUPPORT				2
58	SM6040602TP	SCREW M4 L=6				4
59	40032184	LOWER_SHAFT_REAR_BEARING_BRACKET				1
60	SB108000200	SIDE BEARING				1
61	SM6040460TP	SCREW				1
62	WP0450801SD	WASHER 4.5X10X0.8				1
63	SL6041692TN	SCREW				2
64	WP0482086SD	WASHER 4.8X11.5X2				2
65	HX00150000B	CABLE CLIP				2
66	SL4040891SC	SCREW M4 L=8				2
67	40032182	LOWER_SHAFT				1
68	40014965	SHUTTLE(H)				1

WIPER MECHANISM COMPONENTS

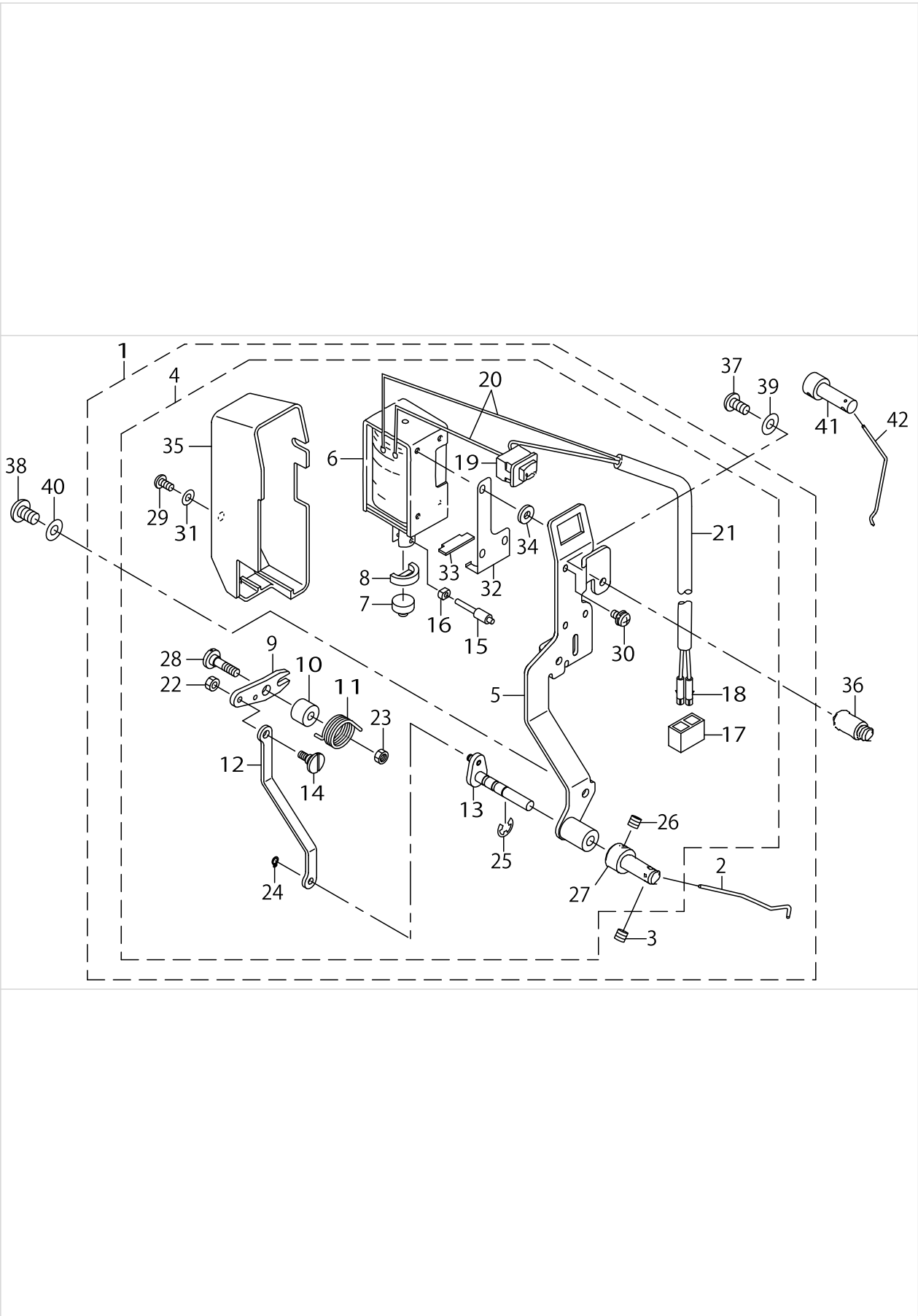

WIPER MECHANISM COMPONENTS

No.	Parts No.	Parts name	Remarks	Level	Cons	Qty
1	40086363	WIPER_ASM				1
2	B2107210D00	WIPER		*		1
3	SM8040412TP	SET SCREW M4 L=4		*		1
4	40086364	WIPER_B_ASM		*		1
5	40086355	WIPER_BASE_ASM		*		1
6	40030956	WIPER_SOLENOID		*		1
7	22955900	WIPER RUBBER A		*		1
8	22956007	WIPER RUBBER B		*		1
9	40086350	WIPER_LINK_A		*		1
10	40086353	WIPER_HINGE_SCREW_COLLAR		*		1
11	40086349	WIPER_SPRING		*		1
12	40086357	WIPER_LINK_B		*		1
13	40086358	WIPER_DRIVING_SHAFT_ASM		*		1
14	22956908	WIPER LINK B HINGE SCREW		*		1
15	40086352	WIPER_SOLENOID_SHAFT		*		1
16	40091894	SLIDE_BLOCK		*		1
17	HK034610020	2-POLE NYLON PLUG		*		1
18	HK03464000B	PIN CONTACT		*		2
19	HA006000000	SWITCH		*		1
20	HW200390000	ELECTRIC WIRE		*		0.04
21	HW500070000	2-CORE CABTYRE CORD		*		1.8
22	NS6090310SP	NUT 9/64-40		*		1
23	NM6050001SC	NUT M5		*		1
24	RC0370411KP	RETAINING RING		*		1
25	RE0500000K0	E-RING		*		1
26	SM8040412TP	SET SCREW M4 L=4		*		1
27	40086354	WIPER_SHAFT_CAP		*		1
28	40086351	SHOULDER_SCREW		*		1
29	SM4030601SN	SCREW M3X6		*		1
30	SL4031091SC	SCREW M3X10		*		3
31	WP0320501SC	WASHER M3		*		1
32	40037500	RUBBER HOLDER		*		1
33	40037501	STOPPER RUBBER		*		1
34	WP0482086SD	WASHER 4.8X11.5X2		*		3
35	22955504	WIPER COVER		*		1
36	40025440	WIPER_STUD_TOP				1
37	SM4040855SP	SCREW				1
38	SM4050855SP	SCREW				1
39	WP0450801SP	WASHER				1
40	WP0531001SC	WASHER				1
41	40076294	WIPER_SHAFT_CAP	OPTIONAL PARTS			1
42	B2107210D0B	WIPER	OPTIONAL PARTS			1

TENSION RELEASE & THREAD TENSION COMPONENTS

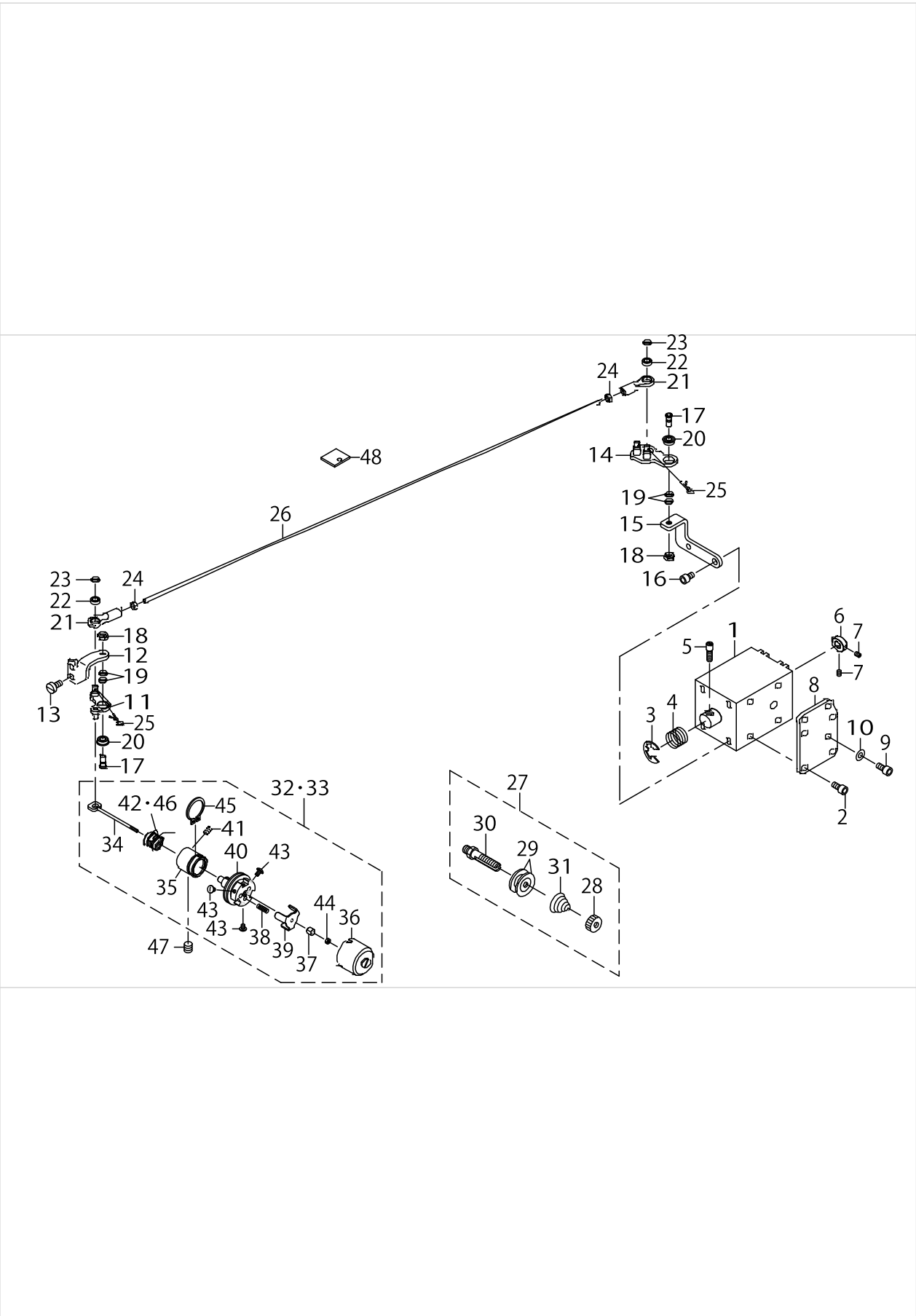

TENSION RELEASE & THREAD TENSION COMPONENTS

No.	Parts No.	Parts name	Remarks	Level	Cons	Qty
1	40073660	AT SOLENOID				1
2	SM6040802TP	SCREW M4X0.7 L=8				4
3	RE0900000K0	E-RING 9				1
4	40006625	SPRING				1
5	40006617	AT_SOL_PIN				1
6	40010477	AT_SOL_COLLAR				1
7	SM8030412TP	SCREW				2
8	40010479	AT_PLATE				1
9	SM6040802TP	SCREW M4X0.7 L=8				2
10	WP0430801SC	WASHER 4.3X9X0.8				2
11	40032343	AT_DRIVE_LINK_F_ASM				1
12	40023993	AT_PIVOT_BASE(F)				1
13	SM6040860TP	SCREW M4 L=8				2
14	40089796	AT_DRIVE_LINK_R_ASM				1
15	40089798	AT_PIVOT_BASE(R)				1
16	SM6040802TP	SCREW M4X0.7 L=8				2
17	40010487	AT_PIVOT_SCREW				2
18	NM6040003SC	NUT M4				2
19	40010489	AT_PIVOT_SCREW_WASHER				4
20	40010490	AT_PIVOT_BEARING				2
21	40010497	AT_JOINT				2
22	40010498	AT_JOINT_BEARING				2
23	40010489	AT_PIVOT_SCREW_WASHER				2
24	NM6030001SC	NUT M3				2
25	40006622	AT_SNAP_PIN				2
26	40032190	AT_CONNECTION_BAR				1
27	40010503	THREAD_TENSION_1_ASM.				1
28	22928808	NUT		*		1
29	22921506	THREAD TENSION DISK		*		2
30	40010504	THREAD_TENSION_SHAFT		*		1
31	26218602	FIRST THREAD TENSION SPRING		*		1
32	40029411	THREAD_TENSION_2_ASM.H				1
33	40010508	THREAD_TENSION_2_ASM.	TYPE S			1
34	40010509	TENSION RELEASE PIN		*		1
35	40010510	THREAD_TENSION_POST_BASE		*		1
36	40010511	DISK_STOPPER_HOLDER_CAP		*		1
37	40010512	THREAD_TENSION_SHAFT_COLLAR		*		1
38	40010513	DISK_STOPPER_SPRING		*		3
39	40010514	DISK_STOPPER		*		1
40	40010515	ASSY_THREAD_TENSION_POST		*		1
41	40010478	AT_SOL_COLLAR_SCREW		*		1
42	40029412	THREAD_TAKE-UP_SPRING_H		*	☆	1
43	40010521	HOLD_CAP_SCREW		*		3
44	40010522	SHAFT_NUT		*		1
45	40010523	POST_BASE_C_RING		*		1
46	22921605	THREAD TAKE-UP SPRING	TYPE S	*	☆	1
47	SM8061612TP	SCREW M6X16				1

TENSION RELEASE & THREAD TENSION COMPONENTS

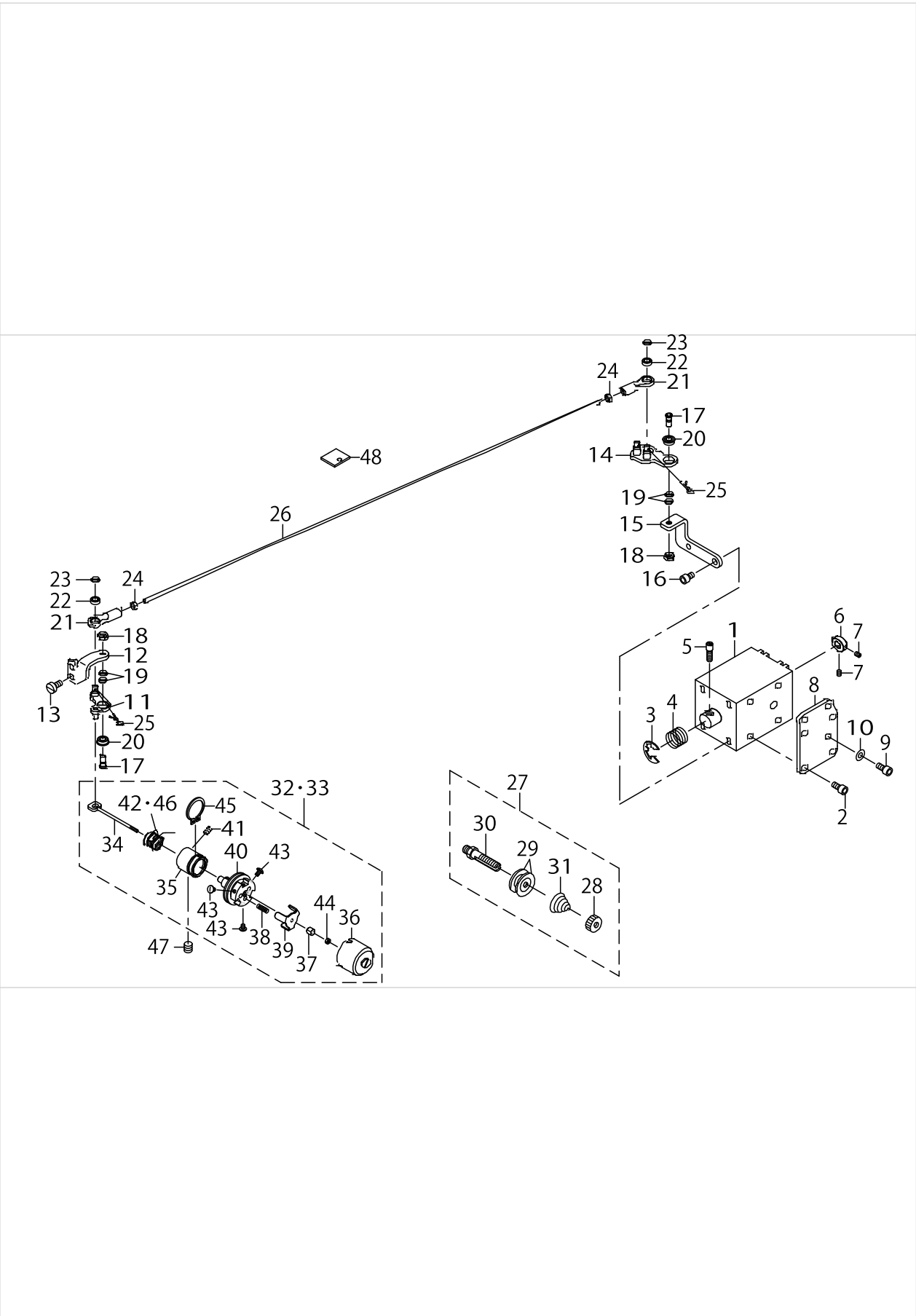

TENSION RELEASE & THREAD TENSION COMPONENTS

No.	Parts No.	Parts name	Remarks	Level	Cons	Qty
48	40013967	AT FELT				1

THREAD TRIMMER MECHANISM COMPONENTS

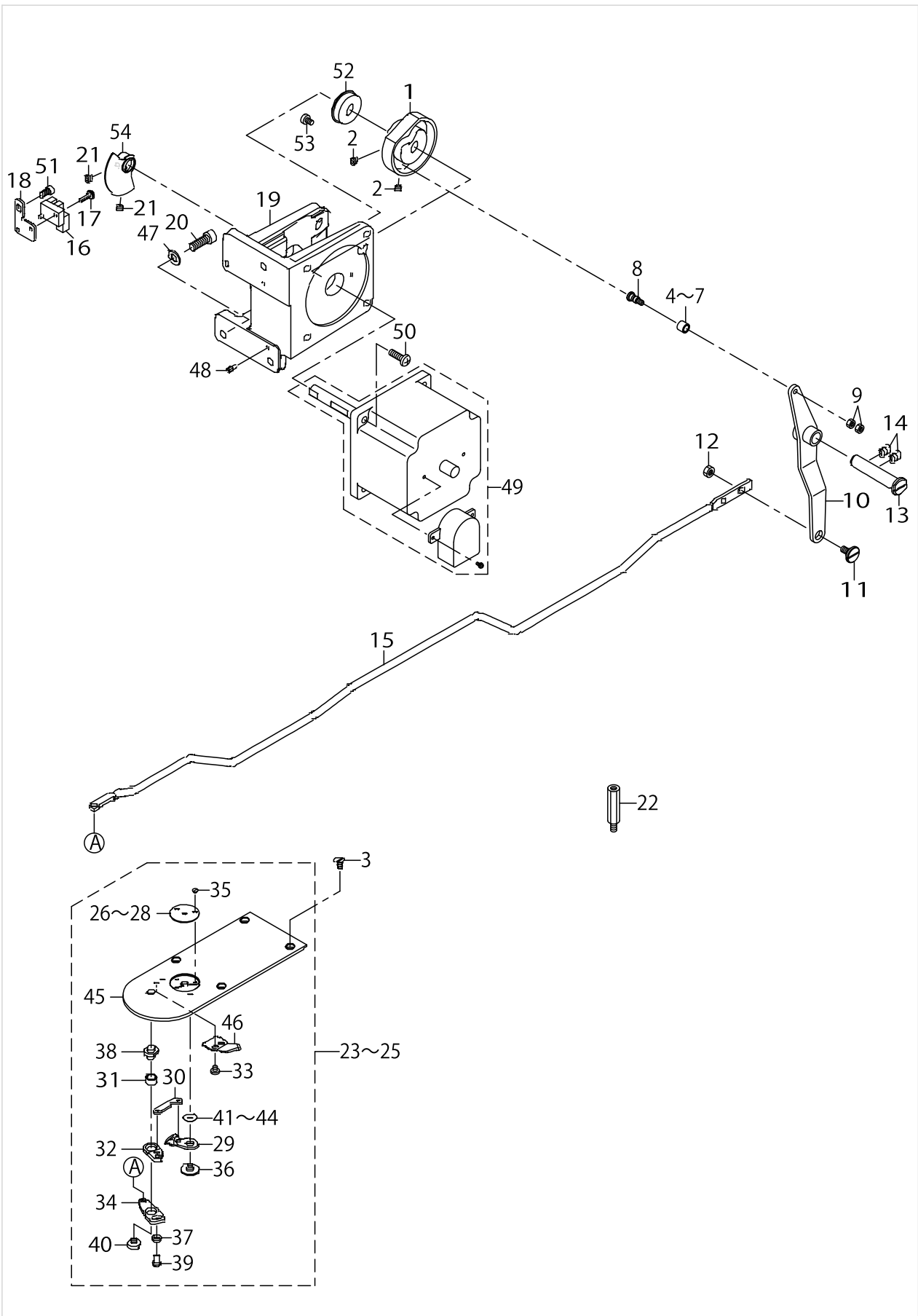

THREAD TRIMMER MECHANISM COMPONENTS

No.	Parts No.	Parts name	Remarks	Level	Cons	Qty
1	40030936	THREAD_TRIMMER_CAM				1
2	SM8050592TP	SCREW				2
3	SM1040870TP	SCREW				4
4	23517501	NEEDLE CAM ROLLER A	SELECTIVE PARTS			1
5	23517600	NEEDLE CAM ROLLER B	SELECTIVE PARTS			1
6	23517709	NEEDLE CAM ROLLER C	SELECTIVE PARTS			1
7	23517808	NEEDLE CAM ROLLER D	SELECTIVE PARTS			1
8	40040256	ROLLER_SHAFT				1
9	NM6040001SP	NUT M4X0.7				2
10	40072228	THREAD_TRIMMER_LINK_ASM				1
11	SD0800327TP	SHOULDER SCREW				1
12	NM6050001SP	NUT M5				1
13	40023624	THREAD_TRIMMER_SHAFT				1
14	SM8060812TP	SCREW M6 L=8				2
15	40032186	THREAD_TRIMMER_CONNECTING_BAR				1
16	HD00057000A	PHOTO SENSOR				1
17	SL4031091SC	SCREW M3X10				1
18	40010443	SENSOR_INSTALLING_BASE				1
19	40072211	MOTOR_BASE				1
20	SM6061802TP	SCREW M6 L=18				3
21	SM8050592TP	SCREW				2
22	HX00056000A	SPACER B				2
23	40030932	NEEDLE_PLATE_ASM.				1
24	40030933	NEEDLE_PLATE_H_ASM.				1
25	40073085	NEEDLE_PLATE_H_2.4_ASM.				1
26	B242621000A	NEEDLE HOLE GUIDE D=1.6		*	☆	1
27	B242621000B	NEEDLE HOLE GUIDE D=2.0		*	☆	1
28	B242621000D	NEEDLE HOLE GUIDE D=2.4		*	☆	1
29	B2421210AA0	MOVING KNIFE COMPL.		*	☆	1
30	B2418280000	MOVING KNIFE LINK		*		1
31	B2416280000	THREAD CUTTING LEVER RING		*		1
32	B24152800A0	THREAD CUTTER LEVER ASM. SMALL		*		1
33	SS7090410SP	SCREW 9/64-40 L=3.5		*		2
34	B24142800A0	THREAD CUTTER LEVER ASM. LARGE		*		1
35	SS1060210TP	SCREW 3/32-56 L=2.2		*	☆	2
36	B2417210000	MOVING KNIFE HINGE SCREW		*		1
37	WP0450846SP	WASHER		*		1
38	B2417280000	THREAD CUTTER LEVER SHAFT		*		1
39	SS7110740TP	SCREW 11/64-40 L=7		*		1
40	SS6110430TP	SCREW 11/64-40 L=4.0		*		1
41	B242328000D	MOVING KNIFE WASHER D	SELECTIVE PARTS	*		1
42	B242328000C	MOVING KNIFE WASHER C	SELECTIVE PARTS	*		1
43	B242328000A	MOVING KNIFE WASHER A	SELECTIVE PARTS	*		1
44	B242328000B	MOVING KNIFE WASHER B	SELECTIVE PARTS	*		1
45	40030934	NEEDLE_PLATE		*		1
46	B2424210000	COUNTER KNIFE		*	☆	1
47	WP0651001SC	WASHER				3

THREAD TRIMMER MECHANISM COMPONENTS

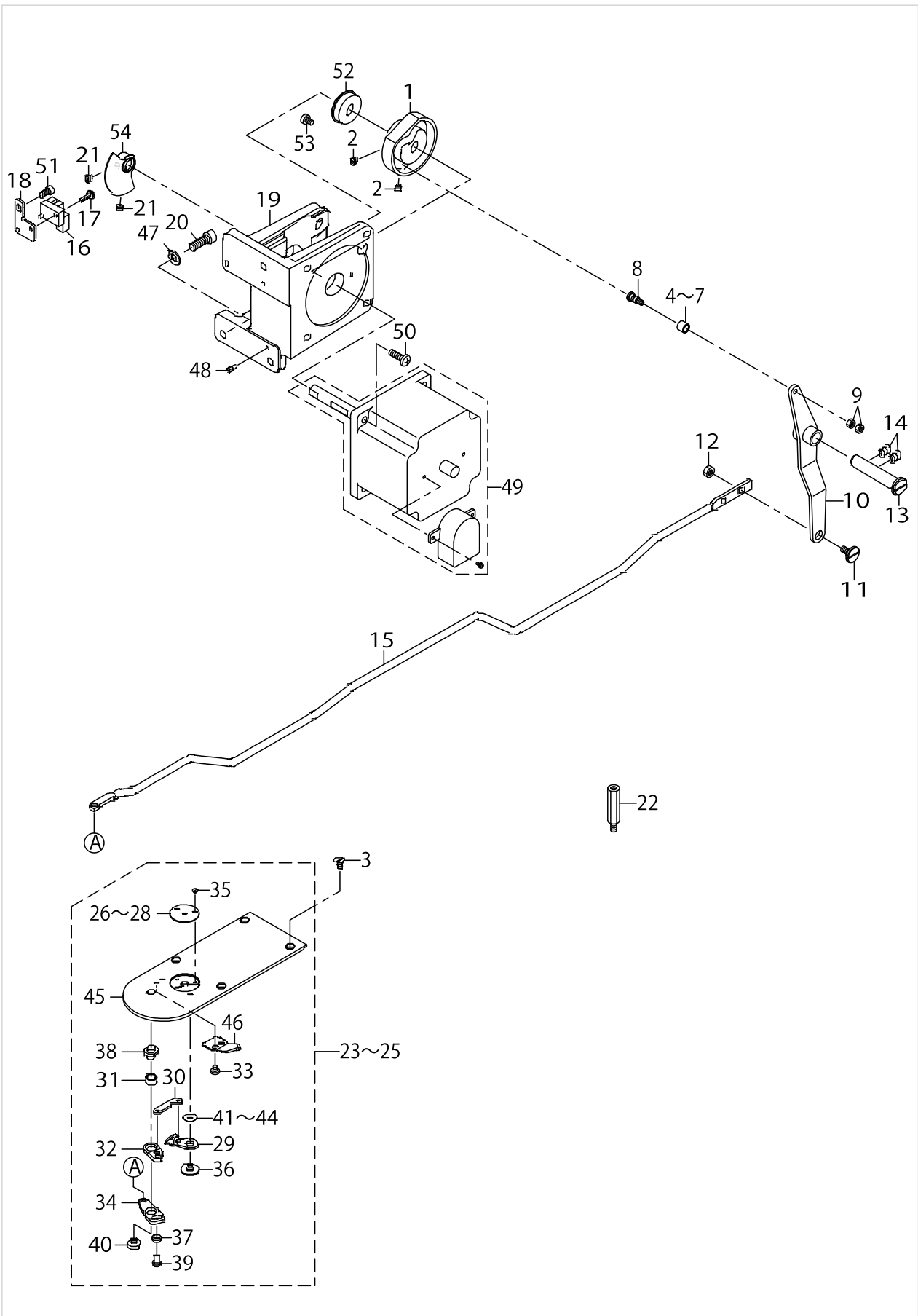

THREAD TRIMMER MECHANISM COMPONENTS

No.	Parts No.	Parts name	Remarks	Level	Cons	Qty
48	B1816215P00	GUIDE PIN				2
49	40103968	ENCODER MOTOR ASM.(TC)				1
50	SM4051655SP	SCREW M5 L=16				4
51	SM6040802TP	SCREW M4X0.7 L=8				1
52	SB110002400	BEARING				1
53	SM6040650TP	SCREW				1
54	40006666	SENSOR_SLIT_ASM				1

THREAD CLAMP COMPONENTS

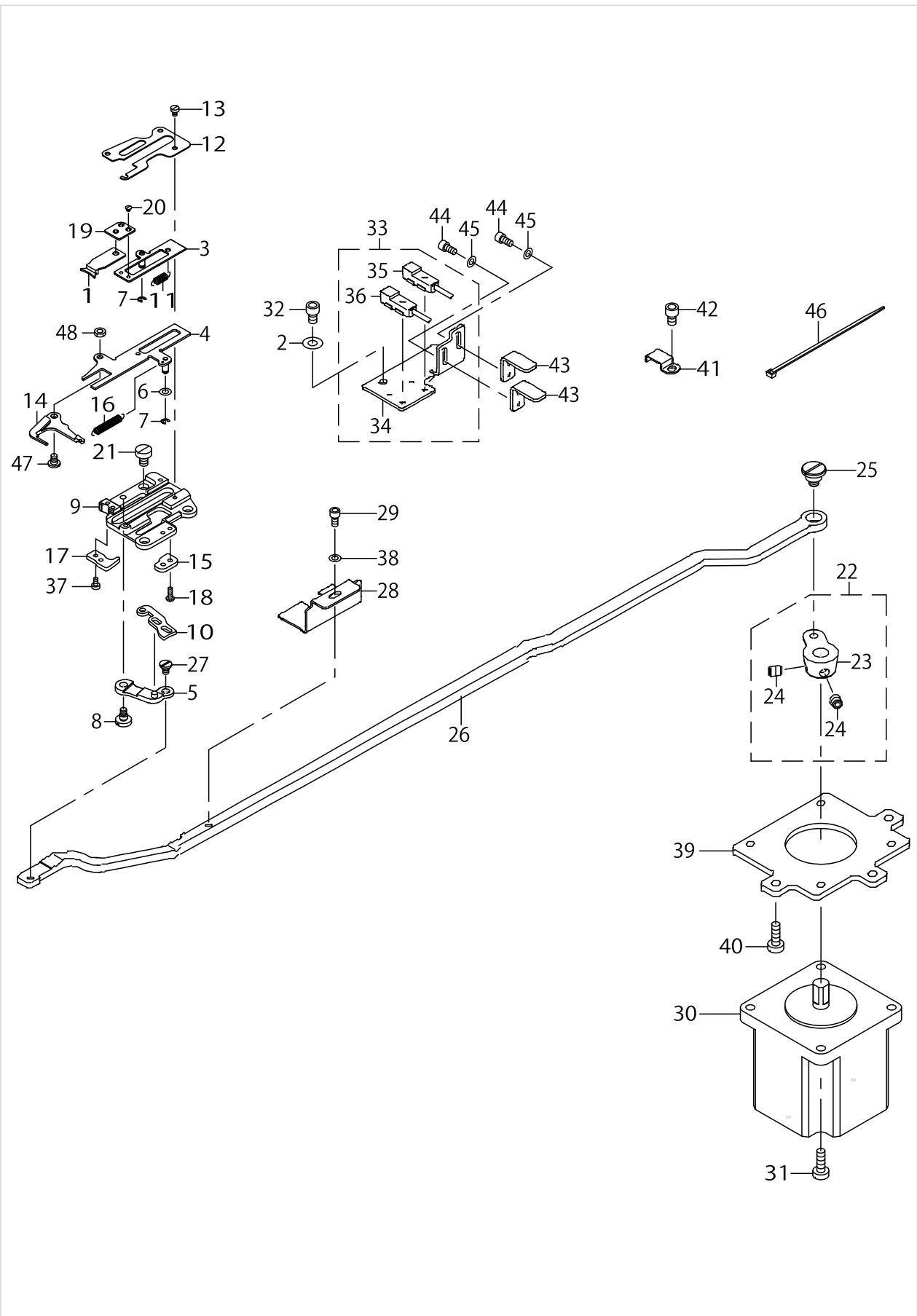

THREAD CLAMP COMPONENTS

No.	Parts No.	Parts name	Remarks	Level	Cons	Qty
1	40006761	TC_CLAMP				1
2	WP0450801SP	WASHER				1
3	40076233	TC_CLAMP_PLATE_ASM				1
4	40076238	TC_SUPPORT_PLATE				1
5	40015800	TC_LINK_ASM.				1
6	WP0320500SC	WASHER M3				2
7	RE0200000K0	E-RING				2
8	SD0400266TP	SHOULDER SCREW				1
9	40076237	TC_BASE				1
10	40010590	TC_CAM_PLATE				1
11	40006780	TC_SPRING				1
12	40076236	TC_BASE_COVER				1
13	SM6020350SP	SCREW M2 L=2.5				4
14	40076239	TC_OPEN_PLATE				1
15	40030943	TC_NOTCH_R_H				1
16	40076232	TC_OPEN_SPRING				1
17	40030942	TC_NOTCH_F_H				1
18	SM4020600SP	SCREW M2 L=6				2
19	40012815	TC_JOINT_ASM				1
20	SM2360110TP	SCREW				2
21	SM6040650TP	SCREW				3
22	40010527	TC_DRIVING_ARM_ASM.				1
23	40010528	TC_DRIVING_ARM		*		1
24	40011152	TC_ARM_SCREW		*		2
25	SD0800407TP	SHOULDER SCREW				1
26	40032187	TC_CONNECTING_LINK				1
27	SD0350156TP	SHOULDER SCREW				1
28	40035161	SENSOR_SLIT				1
29	SM6030602TP	SCREW M3X0.5 L=6				1
30	40085033	STEPPING MOTOR				1
31	SM6041202TP	SCREW M4X0.7 L=12				4
32	SM6040602TP	SCREW M4 L=6				1
33	40040224	TH_SENSOR_ASM.				1
34	40035160	SENSOR_BASE		*		1
35	HD00204000A	SENSOR		*		1
36	HD00204000B	SENSOR		*		1
37	SM6020450TP	SCREW				2
38	WP0320501SD	WASHER				1
39	40033069	MOTOR_BASE				1
40	SM6041202TP	SCREW M4X0.7 L=12				3
41	B3509210000	OIL TUBE HOLDER C				2
42	SM6040602TP	SCREW M4 L=6				2
43	40040082	CONNECTING_LINK_SUPPORT				2
44	SM6030602TP	SCREW M3X0.5 L=6				4
45	WP0320501SD	WASHER				4
46	EA9500B0100	CABLE BAND				2
47	SD0350156TP	SHOULDER SCREW				1

THREAD CLAMP COMPONENTS

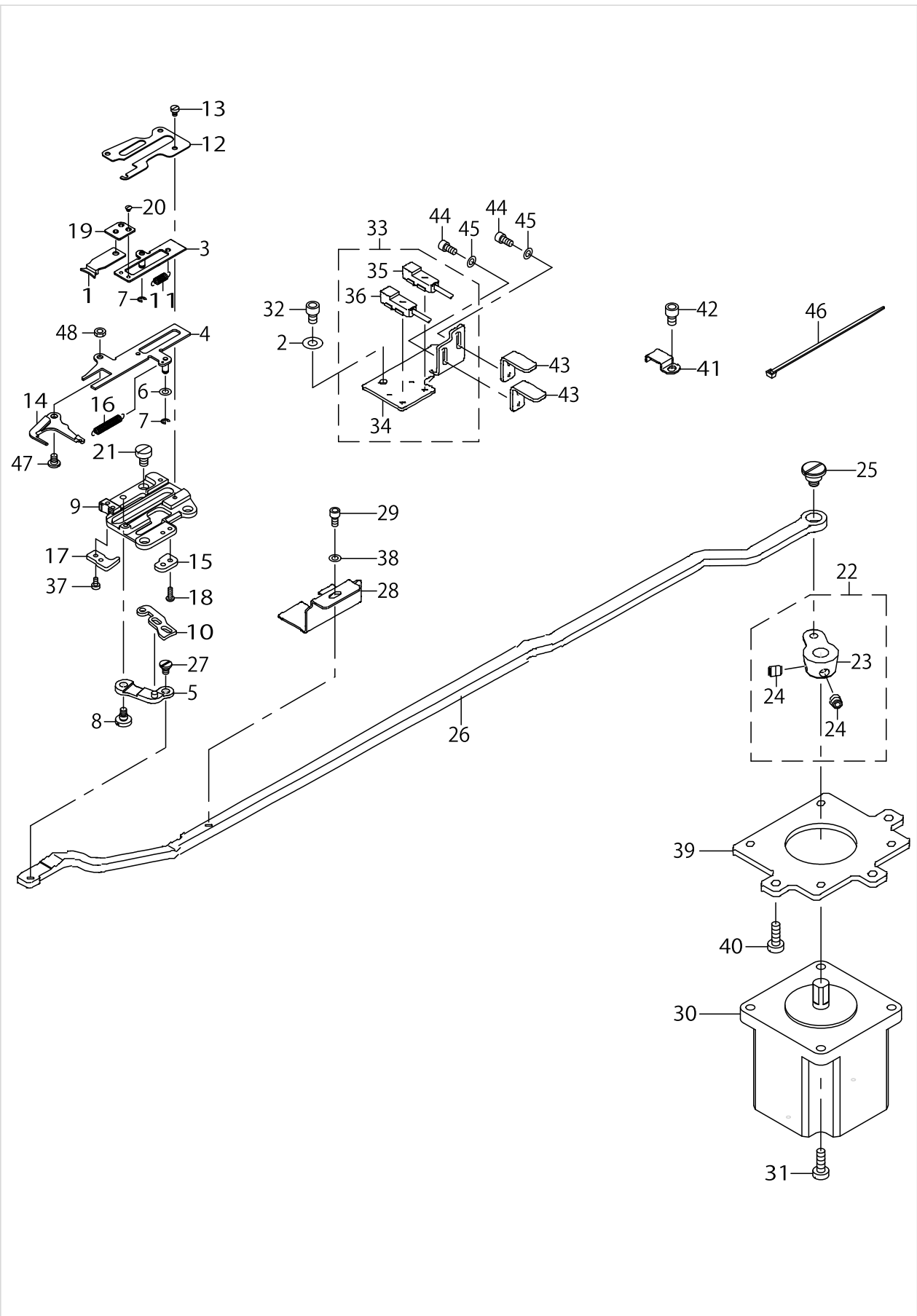

THREAD CLAMP COMPONENTS

No.	Parts No.	Parts name	Remarks	Level	Cons	Qty
48	NM6030003SC	NUT M3				1

X-Y COMPONENTS (1)

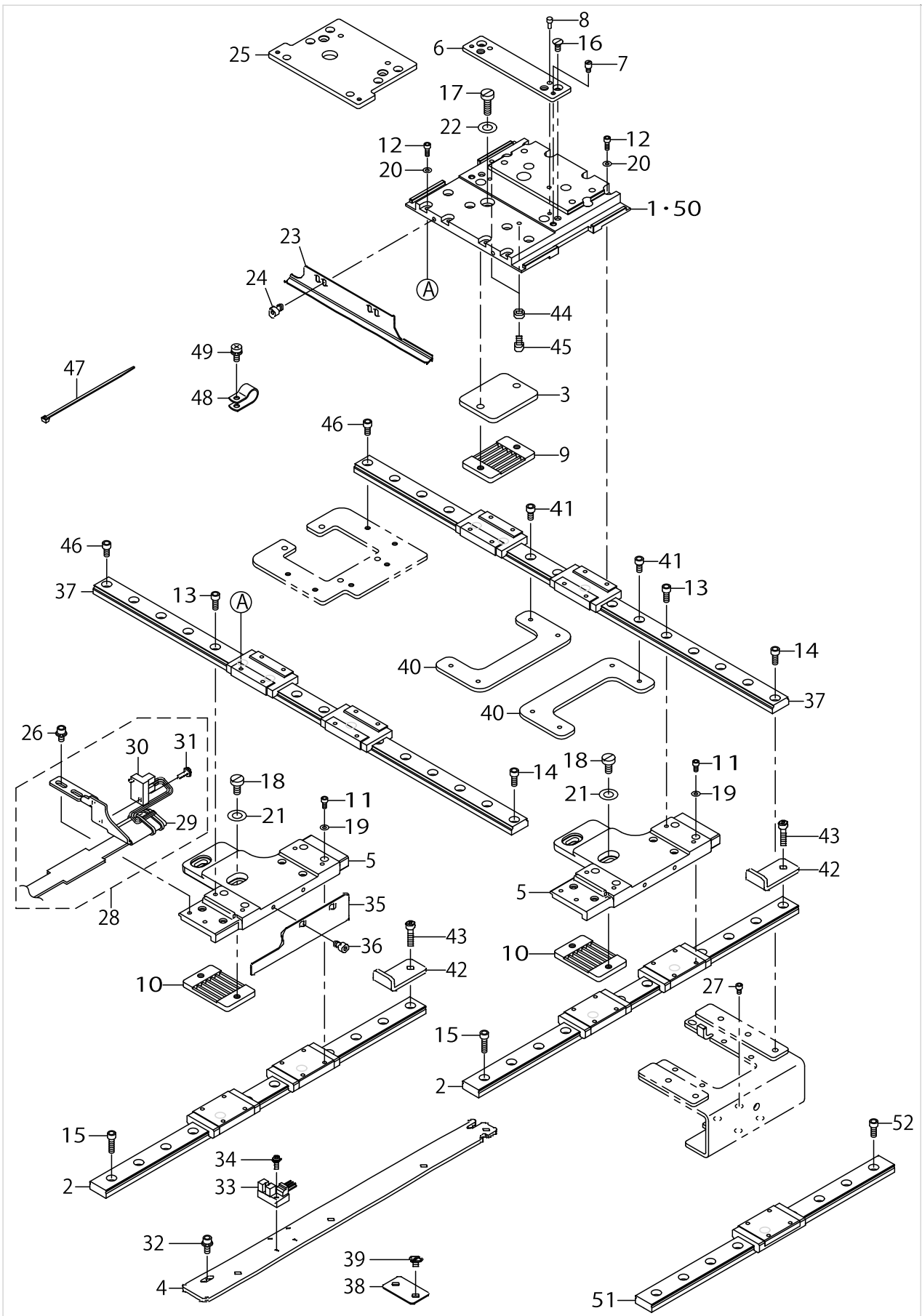

X-Y COMPONENTS (1)

No.	Parts No.	Parts name	Remarks	Level	Cons	Qty
1	40089799	X_FEED_BASE	FOR AMS-221EN-2516		☆	1
2	40089777	Y_LM_GUIDE			☆	2
3	40032205	X_BELT_PRESSER_FIX_PLATE				1
4	40032239	Y_SENSOR_INSTALLING_PLATE				1
5	40089779	Y_FEED_BASE			☆	2
6	40032217	LOWER_PLATE_INSTALLING_PLATE	FOR AMS-221EN-2516			1
7	B151902600G	HINGE STUD				2
8	B1816280000	GUIDE PIN				2
9	40032219	BELT_RECEIVER				1
10	40032219	BELT_RECEIVER				2
11	SM6030602TP	SCREW M3X0.5 L=6				16
12	SM6030802TP	SCREW M3X0.5 L=8				16
13	SM6041002TP	SCREW M4 L=10				8
14	SM6041002TP	SCREW M4 L=10				5
15	SM6041402TP	SCREW M4 L=14				8
16	SM1040870TP	SCREW				2
17	SM6051600SP	SCREW M5 L=16				2
18	SM6051000SP	SCREW				4
19	WP0320500SD	M3 WASHER				16
20	WP0320501SD	WASHER				16
21	WP0531000SD	WASHER M5				4
22	WP0531000SD	WASHER M5				2
23	40032238	X_SLIT_PLATE				1
24	SM6040602TP	SCREW M4 L=6				2
25	40032218	LOWER_PLATE_INSTALLING_PLATE				1
26	SL6040892TN	BOLT				2
27	SM6030502TP	BOLT M3X5				4
28	40073082	X_SENSOR_INSTALLING_PLATE_ASM.				1
29	40040222	X SENSOR CABLE ASM		*		1
30	HD000570000	SENSOR		*		1
31	SL4031091SC	SCREW M3X10		*		1
32	SL6041092TN	SCREW				2
33	HD00057000A	PHOTO SENSOR				1
34	SL4031091SC	SCREW M3X10				1
35	40032240	Y_SLIT_PLATE				1
36	SM6040602TP	SCREW M4 L=6				2
37	40032209	X_LM_GUIDE				2
38	B4022221D00	FLAT CABLE CLAMP				3
39	SM6040650TP	SCREW				6
40	40032223	X_LM_GUIDE_SUPPORT_PLATE				2
41	SM6040802TP	SCREW M4X0.7 L=8				4
42	40043098	Y_STOPPER_STAY	FOR AMS-221EN-2516			2
43	SM6041802TP	SCREW M4 L=18	FOR AMS-221EN-2516			2
44	B3013141H0A	WASHER	FOR AMS-221EN-2516			2
45	SM6040802TP	SCREW M4X0.7 L=8	FOR AMS-221EN-2516			2
46	SM6040802TP	SCREW M4X0.7 L=8				4
47	EA9500B0100	CABLE BAND				8

X-Y COMPONENTS (1)

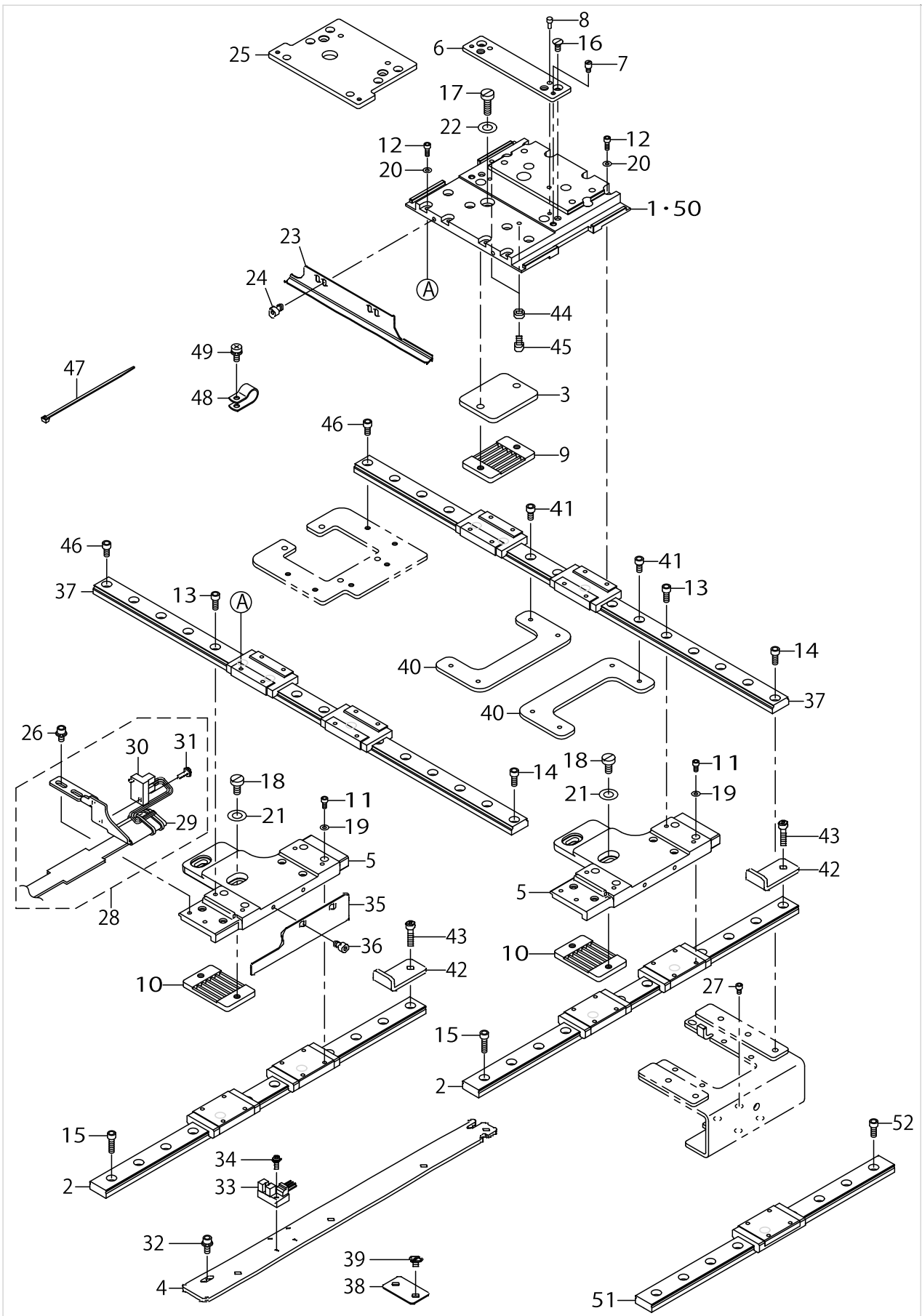

X-Y COMPONENTS (1)

No.	Parts No.	Parts name	Remarks	Level	Cons	Qty
48	HX00150000D	CABLE CLIP				2
49	SL4041091SC	SCREW M4 L=10				2
50	40032200	X_FEED_BASE				1
51	40089778	Y_SUPPORT_LM_GUIDE			☆	1
52	SM6041002TP	SCREW M4 L=10				7

X-Y COMPONENTS (2)

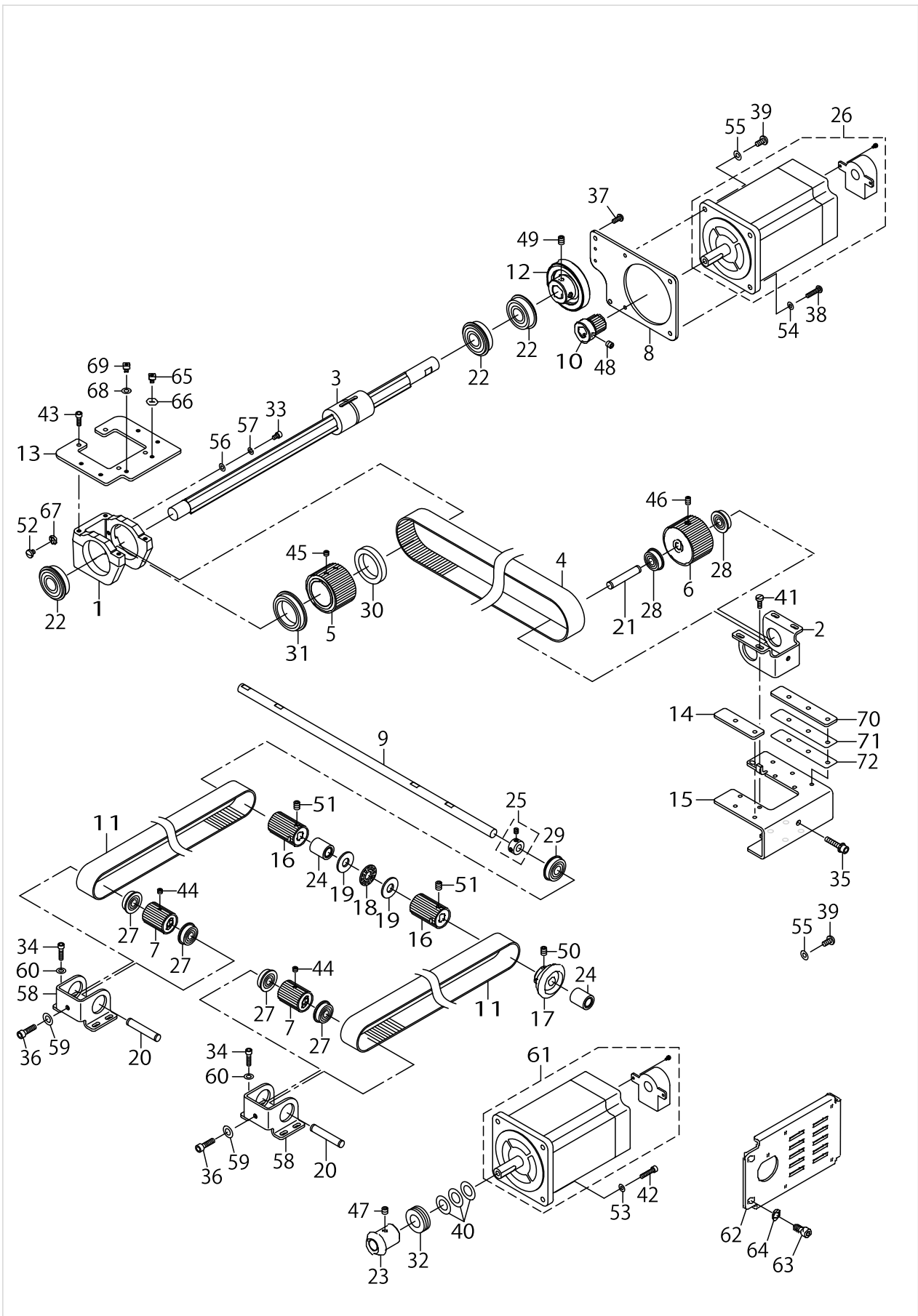

X-Y COMPONENTS (2)

No.	Parts No.	Parts name	Remarks	Level	Cons	Qty
1	B2504221D00	X DRIVE BRACKET				1
2	B2505221D00	DRIVEN BRACKET				1
3	40032192	X_DRIVE_SPLINE_SHAFT				1
4	40057368	X_TIMING_BELT				1
5	40057370	X_DRIVE_SPROCKET				1
6	40057371	X_DRIVEN_SPROCKET				1
7	40032197	Y_DRIVEN_SPROCKET				2
8	40078108	MOTOR_INSTALLING_PLATE			☆	1
9	40032203	Y_DRIVE_SHAFT				1
10	B2525223C00	X DRIVE WHEEL				1
11	40093291	Y_TIMING_BELT				2
12	B2534223C00	X DRIVEN WHEEL				1
13	40032210	X_DRIVE_BRACKET_BASE				1
14	40121671	BRACKET_BASE_SPACER_A				2
15	40121232	X_DRIVEN_BRACKET_BASE				1
16	40032215	Y_DRIVE_SPROCKET				2
17	40032216	Y_DRIVEN_GEAR				1
18	11272408	THRUST COLLAR				1
19	16992604	THRUST WASHER				2
20	22687701	SPRING SHAFT				2
21	22687701	SPRING SHAFT				1
22	B1802180000	BUSHING FRONT				3
23	40032221	Y_DRIVE_GEAR				1
24	GAT23301000	BEARING A 10				2
25	CS100081CSP	THRUST COLLAR ASM.				1
26	40104419	ENCODER MOTOR ASM.(X-Y)				1
27	SB108000500	RADIAL BEARING				4
28	SB108000500	RADIAL BEARING				2
29	SB110001300	BEARING				1
30	SB130000200	BEARING				1
31	SB130000300	BEARING				1
32	SB412000100	BEARING				1
33	SM6040602TP	SCREW M4 L=6				1
34	SM6041602TP	SCREW M4X0.7 L=16				8
35	SL6052592TN	BOLT				1
36	SM6051802TP	SCREW M5 L=18				2
37	SM4041055SP	SCREW				2
38	SM4042055SP	SCREW				2
39	SM4051255SP	SCREW. M5 L=12				2
40	B2537221D00	Y DRIVE WHEEL SPACER				3
41	SM6041150TP	SCREW				4
42	SM6041802TP	SCREW M4 L=18				4
43	SM6041202TP	SCREW M4X0.7 L=12				4
44	SM8050412TP	SCREW M5 L=4				2
45	SM8050412TP	SCREW M5 L=4				2
46	SM8050812TP	SCREW M5X8				1
47	SM8060602TP	SCREW M6X6				2

X-Y COMPONENTS (2)

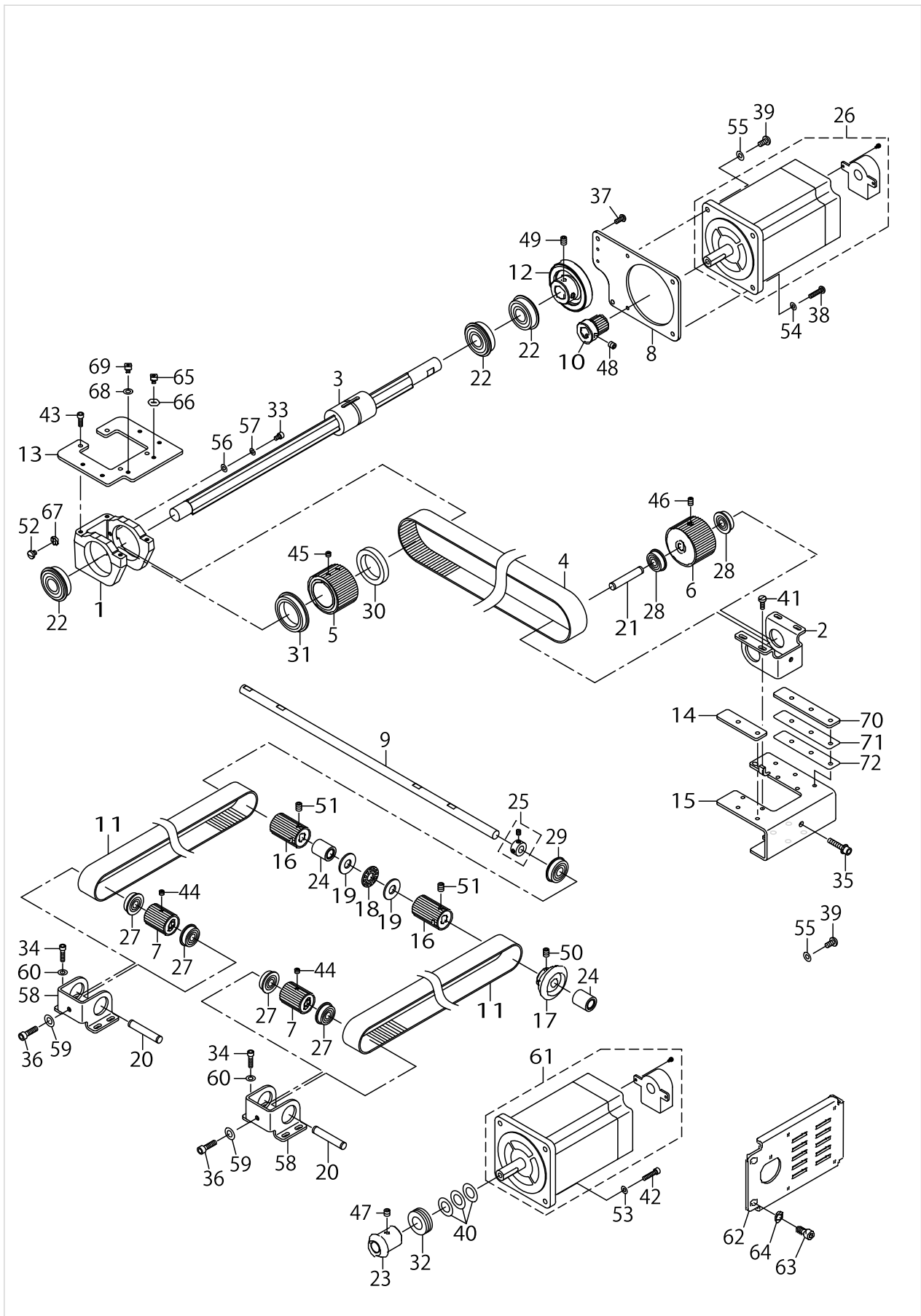

X-Y COMPONENTS (2)

No.	Parts No.	Parts name	Remarks	Level	Cons	Qty
48	SM8060602TP	SCREW M6X6				2
49	SM8060802TP	SCREW M6 L=8				2
50	SM8060812TP	SCREW M6 L=8				2
51	SM8060812TP	SCREW M6 L=8				4
52	SM6050800SP	SCREW M5 L=8				1
53	WP0482086SD	WASHER 4.8X11.5X2				4
54	WP0482086SD	WASHER 4.8X11.5X2				2
55	WP0501016SD	WASHER 5X10.5X1				2
56	WP0430801SC	WASHER 4.3X9X0.8				1
57	WS0410002KN	SPRING WASHER				1
58	40032191	Y_DRIVEN_BRACKET				2
59	WP0531001SC	WASHER				2
60	WP0450000SD	WASHER 4.5X8X0.5				8
61	40104419	ENCODER MOTOR ASM.(X-Y)				1
62	40043096	FAN_INSTALLING_PLATE_A				1
63	SM6061202TN	BOLT				2
64	WP0651001SC	WASHER				2
65	SM6040602TP	SCREW M4 L=6	FOR AMS-221EN-2516			1
66	WP0482086SD	WASHER 4.8X11.5X2	FOR AMS-221EN-2516			1
67	WP0531000SD	WASHER M5				1
68	WP0450000SD	WASHER 4.5X8X0.5				1
69	SM6040602TP	SCREW M4 L=6				1
70	40121230	BRACKET_BASE_SPACER				1
71	40121766	P=SPACER				2
72	40121767	P=SPACER_0.1				4

CLOTH FEED MECHANISM COMPONENTS (1)

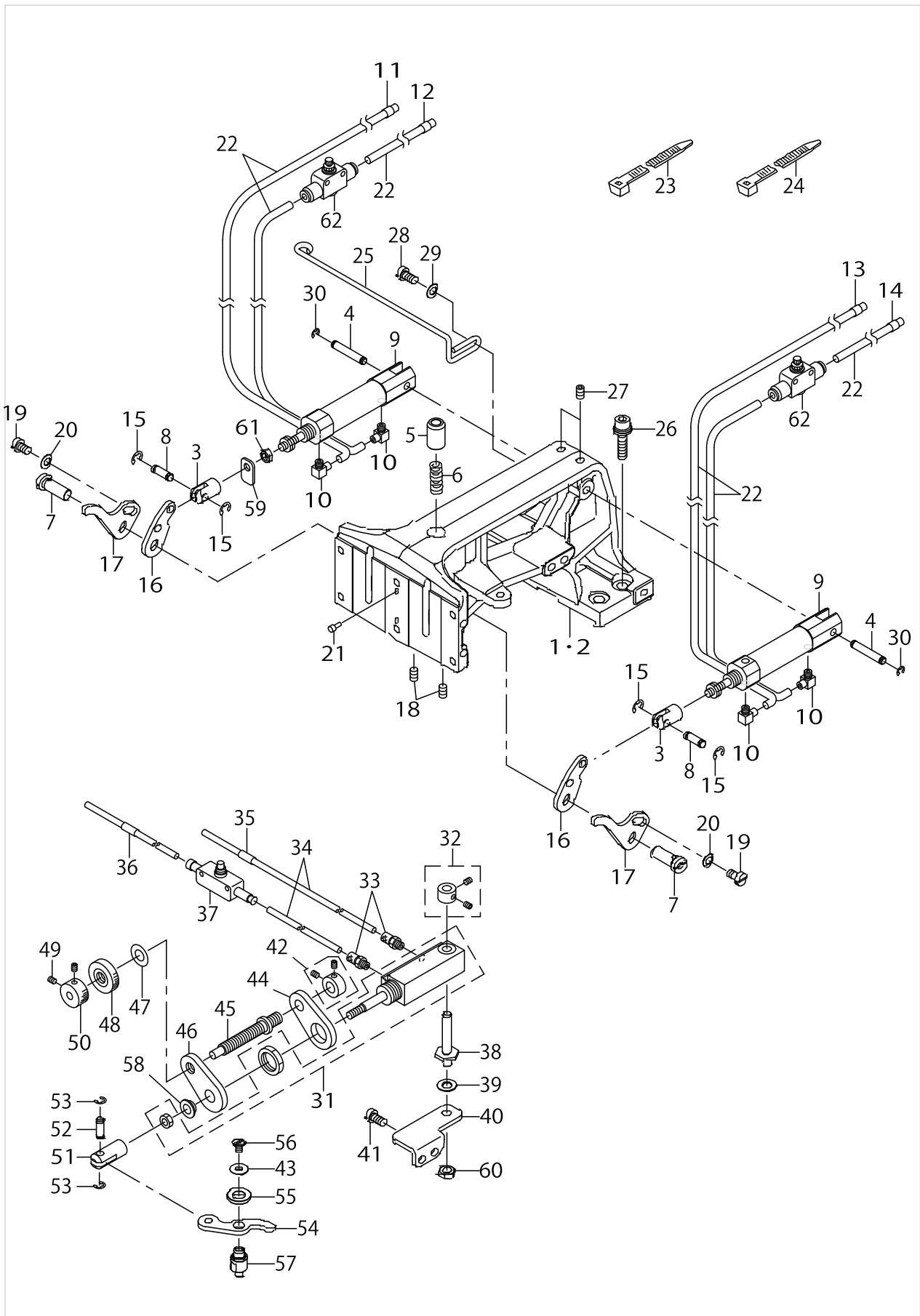

CLOTH FEED MECHANISM COMPONENTS (1)

No.	Parts No.	Parts name	Remarks	Level	Cons	Qty
1	40044186	CLOTH_FEED_BASE_3020				1
2	40034568	CLOTH_FEED_BASE_2516				1
3	40023644	CYLINDER KNUCKLE				2
4	B1504210000	CONNECTING SHAFT				2
5	26017707	NEEDLE BAR BUSHING LOWER				1
6	B2576220000	SLIDER SPRING				1
7	26023408	FEED STUD				2
8	40023635	CYLINDER PIN				2
9	PA1602509A0	AIR CYLINDER				2
10	PJ046052503	HOSE ELBOW				4
11	B471122000C	AIR TUBE LABEL J03 LEFT				1
12	B471122000D	AIR TUBE LABEL J04 LEFT				1
13	B471122000G	AIR TUBE LABEL J03 RIGHT				1
14	B471122000H	AIR TUBE LABEL J04 RIGHT				1
15	RE0300000K0	E-RING 3				4
16	40032229	LIFTING_LEVER_A				2
17	40032230	LIFTING_LEVER_B				2
18	SM8050812TP	SCREW M5X8				2
19	SM6050800SP	SCREW M5 L=8				2
20	WP0531000SD	WASHER M5				2
21	B1816280000	GUIDE PIN				2
22	BT0400251EB	URETHANE HOSE BLACK				6.34
23	HX00233000B	CABLE BAND				1
24	HX002330000	CLIP				10
25	B2568223C00	AIR TUBE SUPPORT				1
26	SL6062592TN	SCREW				4
27	SM8050812TP	SCREW M5X8				2
28	SM6051000SP	SCREW				2
29	WP0531000SD	WASHER M5				2
30	RE0320000K0	E-RING 3.2				2
31	PA1602510A0	AIR CYLINDER				1
32	B25792290A0	THRUST BEARING				1
33	PJ032052503	HOSE NIPPLE				2
34	BT0400251EB	URETHANE HOSE BLACK				3.04
35	B471122000E	AIR TUBE LABEL J05				1
36	B471122000F	AIR TUBE LABEL J06				1
37	PC012401000	SPEED CONTROLLER				1
38	40034185	SHAFT				1
39	WP0650876SD	WASHER 6.5X13X0.8				1
40	40034186	INSTALLING_PLATE				1
41	SM6051000SP	SCREW				2
42	CS079073BSH	THRUST COLLAR				1
43	WP0431005SP	PLAIN WASHER 4.3X12X1				1
44	B2518215000	BRACKET				1
45	B2527215000	REGULATION SCREW				1
46	B2518215A00	REGULATION PLATE				1
47	WP0820816SD	WASHER 8.2X16X0.8				1

CLOTH FEED MECHANISM COMPONENTS (1)

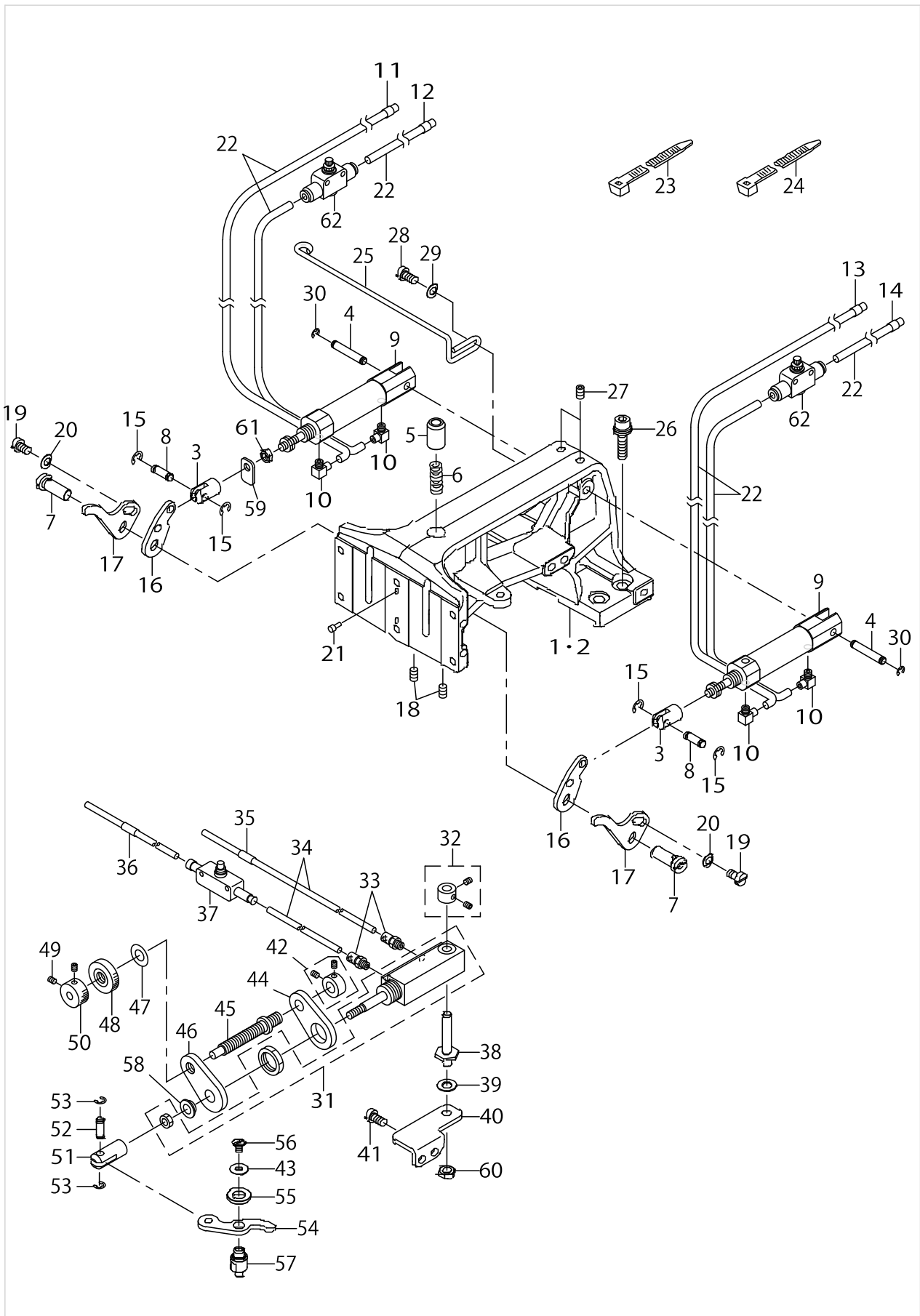

CLOTH FEED MECHANISM COMPONENTS (1)

No.	Parts No.	Parts name	Remarks	Level	Cons	Qty
48	B3012816000	NUT				1
49	SS8110422TP	SCREW 11/64-40 L=4				2
50	B2304205000	KNOB				1
51	B1625220000	CYLINDER KNUCKLE				1
52	40023635	CYLINDER PIN				1
53	RE0300000K0	E-RING 3				2
54	B2516215000	LEVER				1
55	B185351200EA	HOOK SHAFT WASHER				1
56	SM6040650TP	SCREW				1
57	40032231	DRIVING_LINK_SHAFT				1
58	B2548215000	BUSHING				1
59	B2530215000	PRESSER PLATE				1
60	NM6060003SC	NUT M6				1
61	NM6050003SC	NUT M5X0.8				1
62	PC012401000	SPEED CONTROLLER	FOR AMS-221ENHS			2

CLOTH FEED MECHANISM COMPONENTS (2)

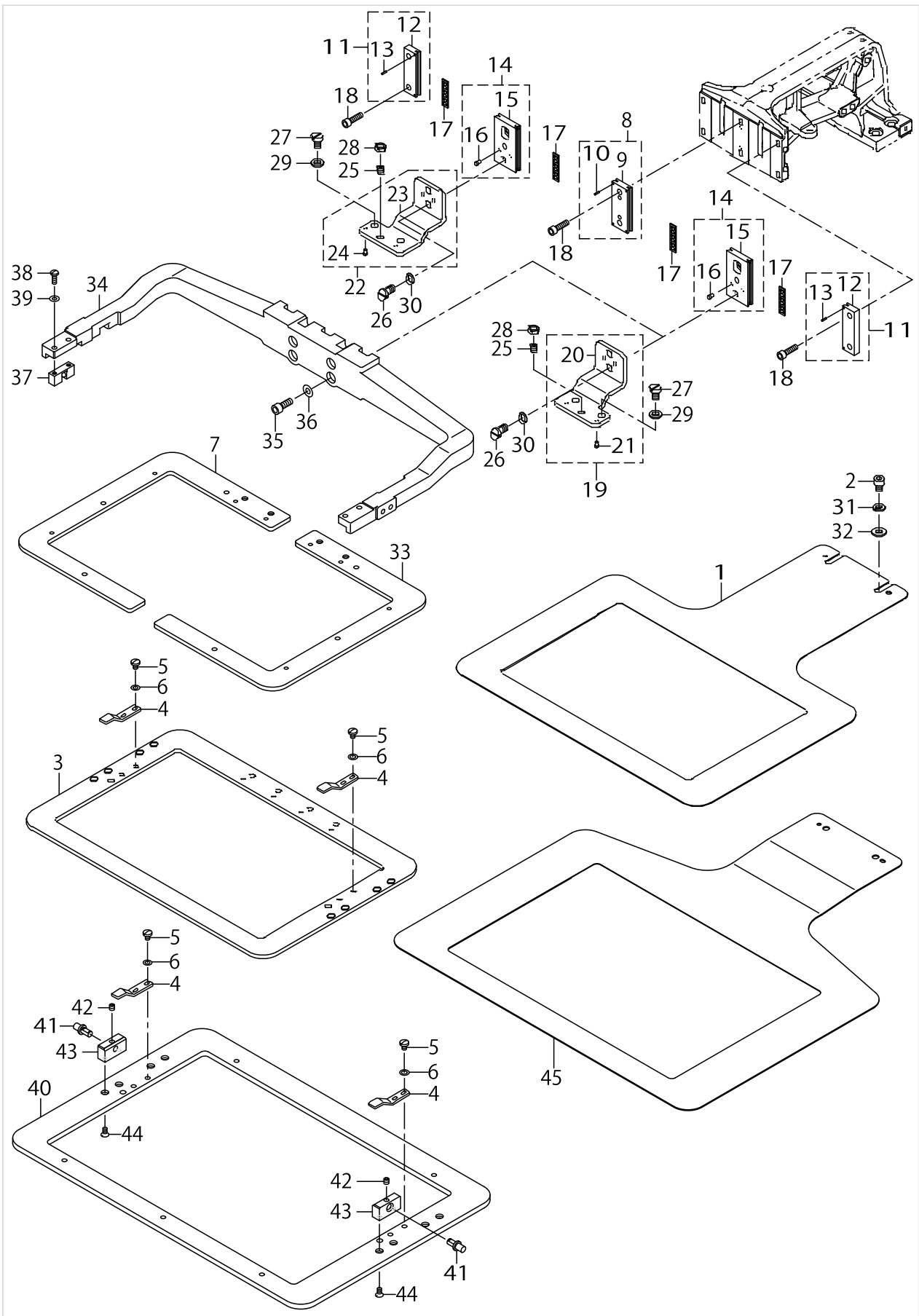

CLOTH FEED MECHANISM COMPONENTS (2)

No.	Parts No.	Parts name	Remarks	Level	Cons	Qty
1	40032226	LOWER_PLATE_2516				1
2	SM6060802TP	SCREW M6 L=8				2
3	40032842	FEEDING_FRAME_2516	FOR AMS-221ENHS			1
4	B2558220000	PLASTIC BLANK PLATE				2
5	SM4050655SP	SCREW M5 L=6				4
6	WP0531000SD	WASHER M5				4
7	40032844	2_STEP_FEEDING_FRAME_2516				1
8	B26132150A0	WORK CLAMP FOOT PLATE A ASM.				1
9	B2613215000	WORK CLAMP FOOT PLATE A		*		1
10	PS0150065KP	SPRING PIN 1.5X6		*		4
11	B25672150A0	WORK CLAMP FOOT PLATE B ASM.				2
12	B2567215000	WORK CLAMP FOOT PLATE B		*		1
13	PS0150065KP	SPRING PIN 1.5X6		*		2
14	40032839	SLIDE_PLATE_ASM				2
15	40032840	SLIDE_PLATE		*		1
16	B1816280000	GUIDE PIN		*		2
17	B2513215000	BEARING				4
18	SM6051802TP	SCREW M5 L=18				6
19	40032835	RECEIVER_PLATE_RIGHT_ASM				1
20	40032836	RECEIVER_PLATE_RIGHT		*		1
21	B1816280000	GUIDE PIN		*		2
22	40032837	RECEIVER_PLATE_LEFT_ASM				1
23	40032838	RECEIVER_PLATE_LEFT		*		1
24	B1816280000	GUIDE PIN		*		2
25	SM8060812TP	SCREW M6 L=8				2
26	SM6061200SP	SCREW				4
27	SM6061010TP	SCREW M6 L=10				4
28	NM6060003SC	NUT M6				2
29	WP0641601SD	WASHER M6				4
30	WP0651056SD	WASHER 6.5X11X1				4
31	WS0610002KP	SPRING WASHER				2
32	WP0611626SP	WASHER 15X6X1.6				2
33	40044329	2_STEP_FEEDING_FRAME_2516_B				1
34	40051500	OUTOR_FRAME_ARM				1
35	SM6061602TP	SCREW M6 L=16				4
36	WP0641600SC	WASHER 6.4X12.5X1.6				4
37	40051770	FEEDING FRAME BALL CATCH				2
38	SM4041255SP	SCREW M4 L=12				4
39	WP0450000SD	WASHER 4.5X8X0.5				4
40	40032843	FEEDING_FRAME_3020				1
41	B2560220000	SUPPORT PIN				2
42	SM8050512TP	SCREW				2
43	40051769	FEEDING FRAME SUPPORT BEARING				2
44	SM1040870TP	SCREW				4
45	40051782	LOWER PLATE 3020				1

TABLE COMPONENTS

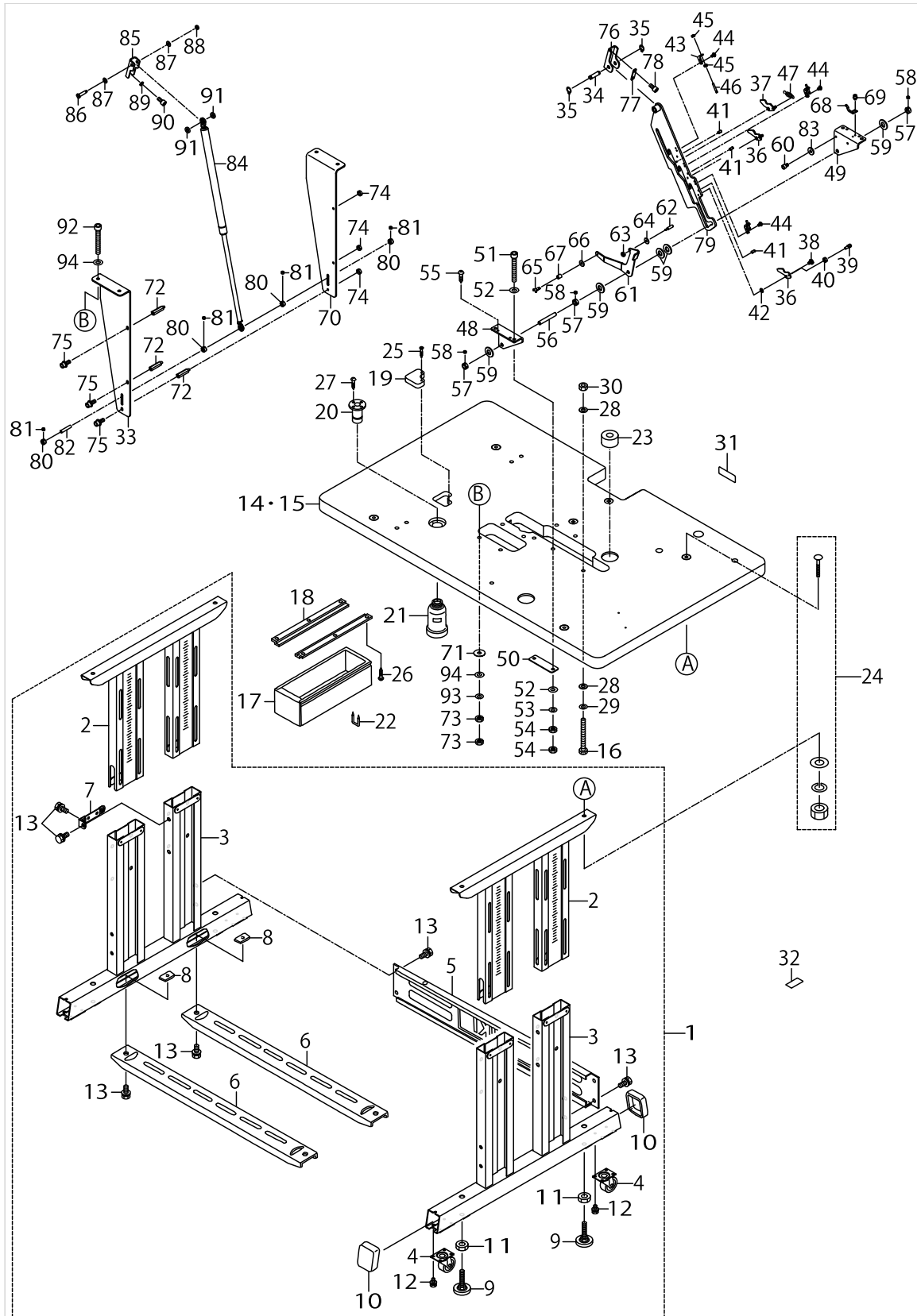

TABLE COMPONENTS

No.	Parts No.	Parts name	Remarks	Level	Cons	Qty
1	B8101221DA0	STAND ASM.				1
2	B8102221DA0	UPPER STAND COMPL.		*		2
3	B8103221DA0	STAND COMPL.		*		2
4	B8150221D00	CASTER		*		4
5	11158300	STAND SIDE SUPPORT		*		1
6	11158409	STAND SIDE SUPPORT		*		2
7	11158516	UPPER STAND PLATE		*		4
8	17007402	NUT		*		4
9	17833658	ADJUSTING BOLT ASM.		*		4
10	B8110373N00	CAP		*		4
11	NM6120003SE	NUT M12		*		4
12	SL9061293SE	WASHER HEXAGONAL BOLT		*		16
13	SL9082093SE	SCREW		*		20
14	40090320	TABLE			☆	2
15	40090434	TABLE_ASM			☆	1
16	SM9087533SC	SCREW M8 L=75				1
17	11155108	DRAWER				1
18	11155207	DRAWER SUPPORT				2
19	B8171223C00	RUBBER ABSORBER				1
20	B8202205000	OIL MANAGEMENT				1
21	B9121012000	OIL CAN				1
22	D8204555D00	DRAWER STOPPER				1
23	G5151171000	CUSHION				2
24	MTJMS00000S	SCREW SET				4
25	SK1382501SE	WOOD SCREW D=3.8 L=25				1
26	SK3311600SC	WOOD SCREW D=3.1 L=16				6
27	SK3311600SC	WOOD SCREW D=3.1 L=16				2
28	WP0841600SE	WASHER 8.4X15.5X1.6				2
29	WS0820002KN	SPRING WASHER M8				1
30	NM6080001SC	NUT M8X1.25				1
31	CM500100001	CE MARKING LABEL	FOR JE			1
32	16870206	GRAVITY SEAL				1
33	40098325	LIFTER_BRACKET_A			☆	1
34	40091078	PIVOT_SHAFT			☆	1
35	RC0100001KP	SNAP RING M10				2
36	40089790	GUIDE_PLATE_B			☆	2
37	40089789	GUIDE_PLATE_A			☆	1
38	SD0600326TP	SHOULDER SCREW D=6 H=3.2				3
39	40011926	SPRING_HOOK				3
40	NM6040001SC	NUT M4X0.7 TYPE1				3
41	PS0400082KP	SPRING PIN				3
42	10523702	WASHER				3
43	40086365	SPRING_HOOK_BRACKET			☆	3
44	SM4040655SP	SCREW M4 L=6				6
45	NS6110310SP	NUT 11/64-40				6
46	26226506	SPRING HOOK				3
47	13888201	SPRING				3

TABLE COMPONENTS

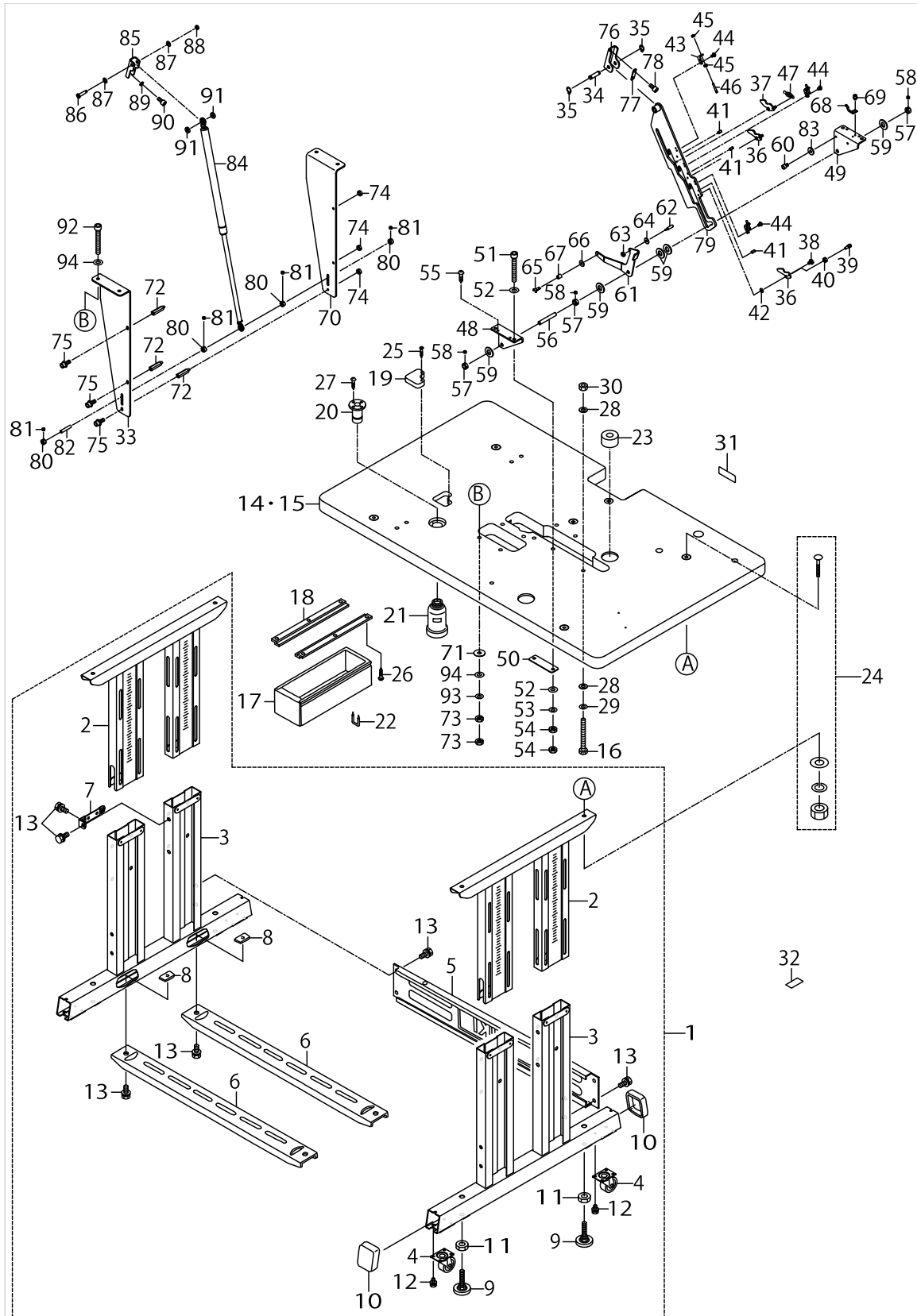
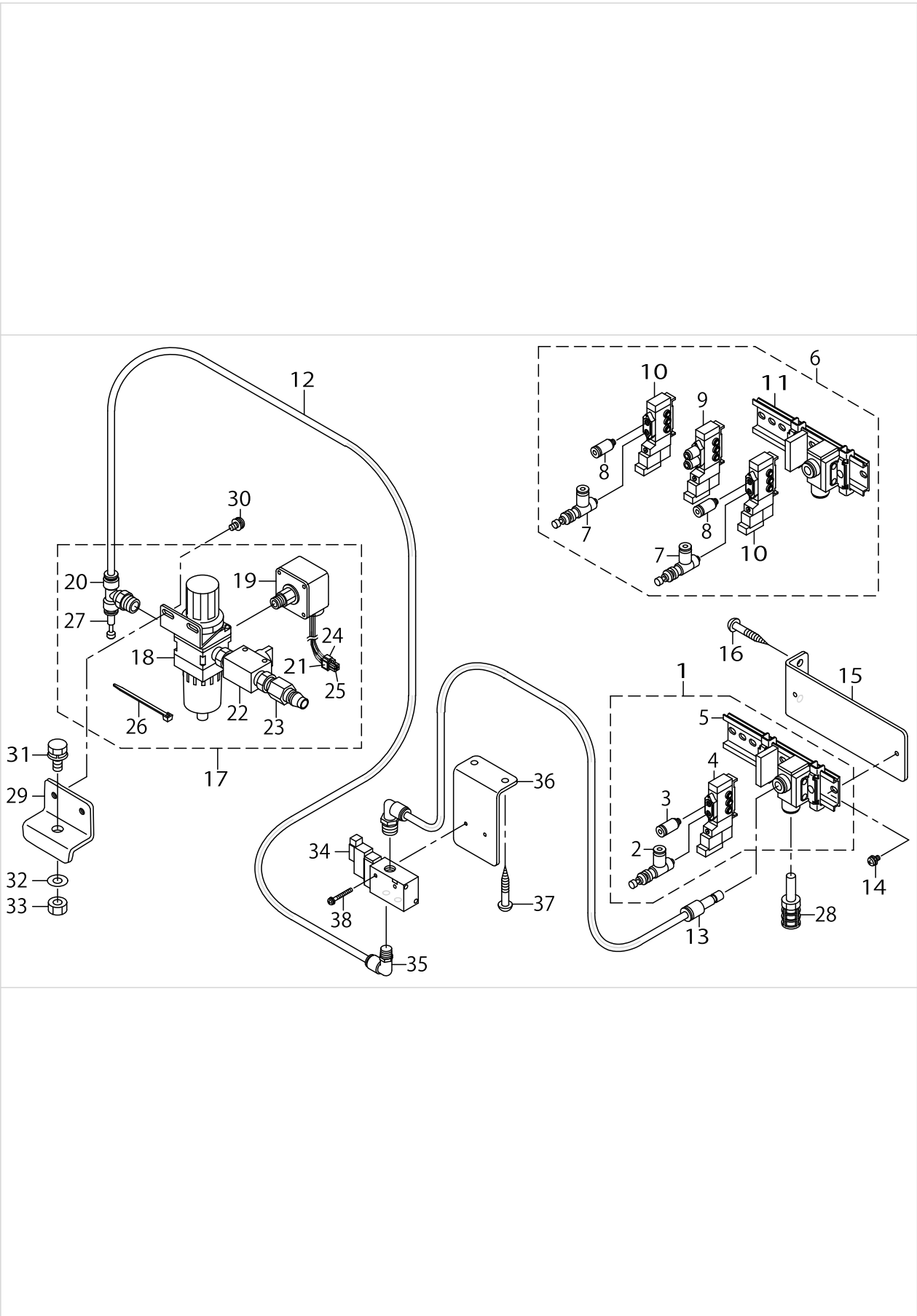

TABLE COMPONENTS

No.	Parts No.	Parts name	Remarks	Level	Cons	Qty
48	40089786	BOTTOM_STOPPER_BASE_A			☆	1
49	40089787	BOTTOM_STOPPER_BASE_B			☆	1
50	40089792	SPACER_B			☆	2
51	SM6086002TP	SCREW				4
52	WP0850002SP	WASHER 8.5X18X1.6				8
53	WS0820002KN	SPRING WASHER M8				4
54	NM6080003SC	NUT M8				8
55	SK3582501SE	WOOD SCREW D=5.8 L=25				4
56	40089791	GUIDE_PIN			☆	1
57	CS1000881TP	THRUST COLLAR				3
58	SM8050412TP	SCREW M5 L=4				6
59	WP1022016SH	WASHER				5
60	SM6050802TP	SCREW M5X0.8 L=8				2
61	40091075	RELEASE_LEVER			☆	1
62	40011205	STUD				1
63	NM6040001SC	NUT M4				1
64	WP0431005SP	PLAIN WASHER 4.3X12X1				1
65	SD0601406TP	SHOULDER SCREW D=6 H=14				1
66	WP0431005SP	PLAIN WASHER 4.3X12X1				1
67	GAW01502000	OILLESS SHAFT HOLDER				1
68	40091076	LOCK_SPRING			☆	1
69	SL6040692TN	BOLT				2
70	40098326	LIFTER_BRACKET_B			☆	1
71	B1628191B00	BODY CAP B				4
72	40016705	OIL_TANK_STUD_A				3
73	NM6080003SC	NUT M8				8
74	NM6060003SC	NUT M6				3
75	SL6061692TN	BOLT				3
76	40089785	TOP_STOPPER_BASE			☆	1
77	40091083	SPACER_A			☆	1
78	SM6061202TN	BOLT				2
79	40091362	STOPPER_PLATE_ASM			☆	1
80	CS0800881TP	THRUST COLLAR				4
81	SM8050412TP	SCREW M5 L=4				8
82	B2539223C00	X IDLER SHAFT				1
83	WP0522016SH	WASHER				2
84	40089783	GAS_SPRING			☆	1
85	40089782	LIFTER_BRACKET_C			☆	1
86	40089784	SHOULDER_SCREW			☆	1
87	B1223771000	NEEDLE ROD CRANK WASHER				2
88	NM6060001SC	NUT M6				1
89	WS0610002KP	SPRING WASHER				2
90	SM6061202TN	BOLT				2
91	40051536	CUSHION				2
92	SM6086002TP	SCREW				4
93	WS0820002KN	SPRING WASHER M8				4
94	WP0850002SP	WASHER 8.5X18X1.6				8

PNEUMATIC COMPONENTS



PNEUMATIC COMPONENTS

No.	Parts No.	Parts name	Remarks	Level	Cons	Qty
1	40032232	SOLENOID_VALVE_A_ASM	FOR AMS-221ENHS			1
2	PF070501000	PRESSURE DECREASING VALVE		*		1
3	PJ301040505	HALF UNION		*		1
4	PV150209100	SOLENOID VALVE		*		1
5	PV915005000	SOLENOID VALVE INSTALLING BASE		*		1
6	40032233	SOLENOID_VALVE_B_ASM				1
7	PF070501000	PRESSURE DECREASING VALVE		*		2
8	PJ301040505	HALF UNION		*		2
9	PV150209000	5 PORT SOLENOID VALVE		*		1
10	PV150209100	SOLENOID VALVE		*		2
11	PV915005000	SOLENOID VALVE INSTALLING BASE		*		1
12	BT0600401EB	TUBE				0.75
13	PJ301060003	REDUCER				1
14	SL4040891SC	SCREW M4 L=8				2
15	40030950	SORENOID_VALVE_FITTING_BASE				1
16	SK3452500SC	WOOD SCREW D=4.5 L=25				2
17	40030951	FILTER_REGULATOR_ASM.				1
18	PF0552040B0	FILTER REGULATOR		*		1
19	G8124270000	AIR PRESSUE SWITCH		*		1
20	PJ305065202	TEE		*		1
21	E2678453000	CONNECTOR MARKER J78		*		1
22	PV015211000	HAND VALVE		*		1
23	PJ025200003	PLUG		*		1
24	HK034610040	HOUSING		*		1
25	HK034640000	PIN CONTACT		*		3
26	EA9500B0100	CABLE BAND		*		5
27	PX950009000	PLUG		*		1
28	PX050003000	SILENCER				1
29	40023662	FILTER INSTALLING PLATE				1
30	SL4051091SC	SCREW M5X0.8 L=10				2
31	SL9082093SE	SCREW				1
32	WP0871602SE	WASHER 8.7X18X1.6				1
33	NM6080721SE	NUT M8				1
34	PV135129000	3-PORT SOLENOID VALVE				1
35	PJ304065101	ELBOW UNION 6XPT1/8				2
36	40105704	SOLENOID_INSTALLING_PLATE			☆	1
37	SK3452500SC	WOOD SCREW D=4.5 L=25				2
38	SL4032591SC	SCREW M3X25				2

THREAD STAND COMPONENTS

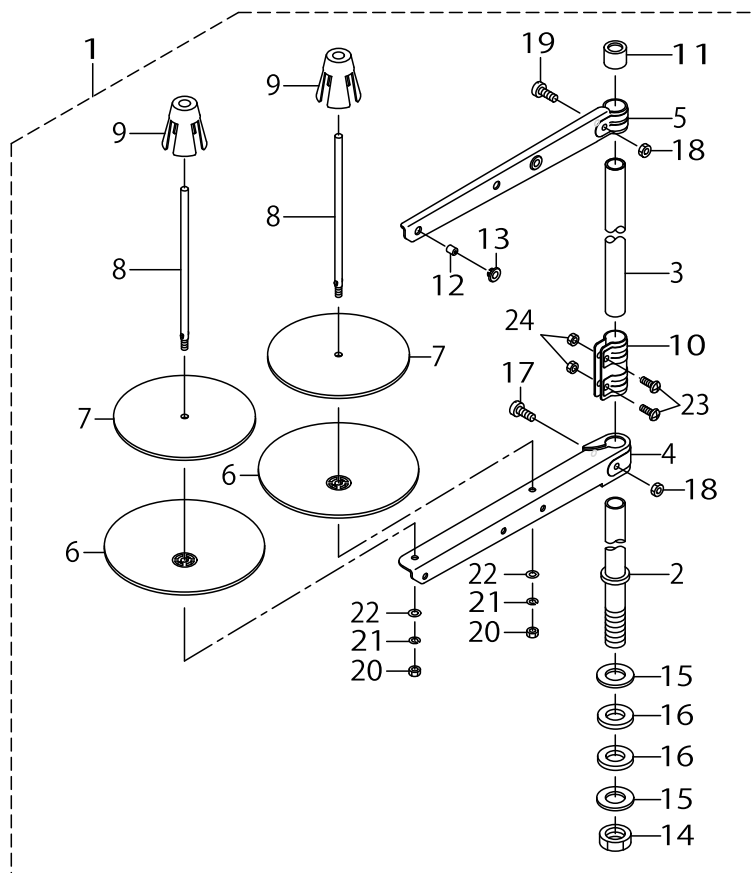

THREAD STAND COMPONENTS

No.	Parts No.	Parts name	Remarks	Level	Cons	Qty
1	40096354	THREAD STAND ASM.				1
2	40085784	SPOOL REST ROD LOWER		*		1
3	40085785	SPOOL REST ROD UPPER		*		1
4	40085786	SPOOL REST ARM LOWER		*		1
5	40085787	SPOOL REST ARM UPPER		*		1
6	40085788	SPOOL REST		*		2
7	40085789	SPOOL REST CUSHION		*		2
8	40085790	SPOOL PIN		*		2
9	40085791	SPOOL RETAINER		*		2
10	40085792	SPOOL REST ROD JOINT		*		1
11	40085793	SPOOL REST ROD RUBBER CAP		*		1
12	40085794	THREAD GUIDE		*		2
13	40085795	THREAD GUIDE BUSHING		*		2
14	40096325	SPOOL REST ROD NUT		*		1
15	WP1612616SE	WASHER 16X30X2.6		*		2
16	40085796	SPOOL REST ROD RUBBER CUSHION		*		2
17	40096326	SPOOL REST ARM LOWER SCREW		*		1
18	NM6050001SE	NUT M5		*		2
19	40096327	SPOOL REST ARM UPPER SCREW		*		1
20	NM6050001SE	NUT M5		*		2
21	WS0510002KN	SPRING WASHER M5		*		2
22	WP0531001SC	WASHER M5		*		2
23	SM4051405SE	SCREW M5 L=14		*		2
24	NM6050001SE	NUT M5		*		2

OPERATION PANEL COMPONENTS

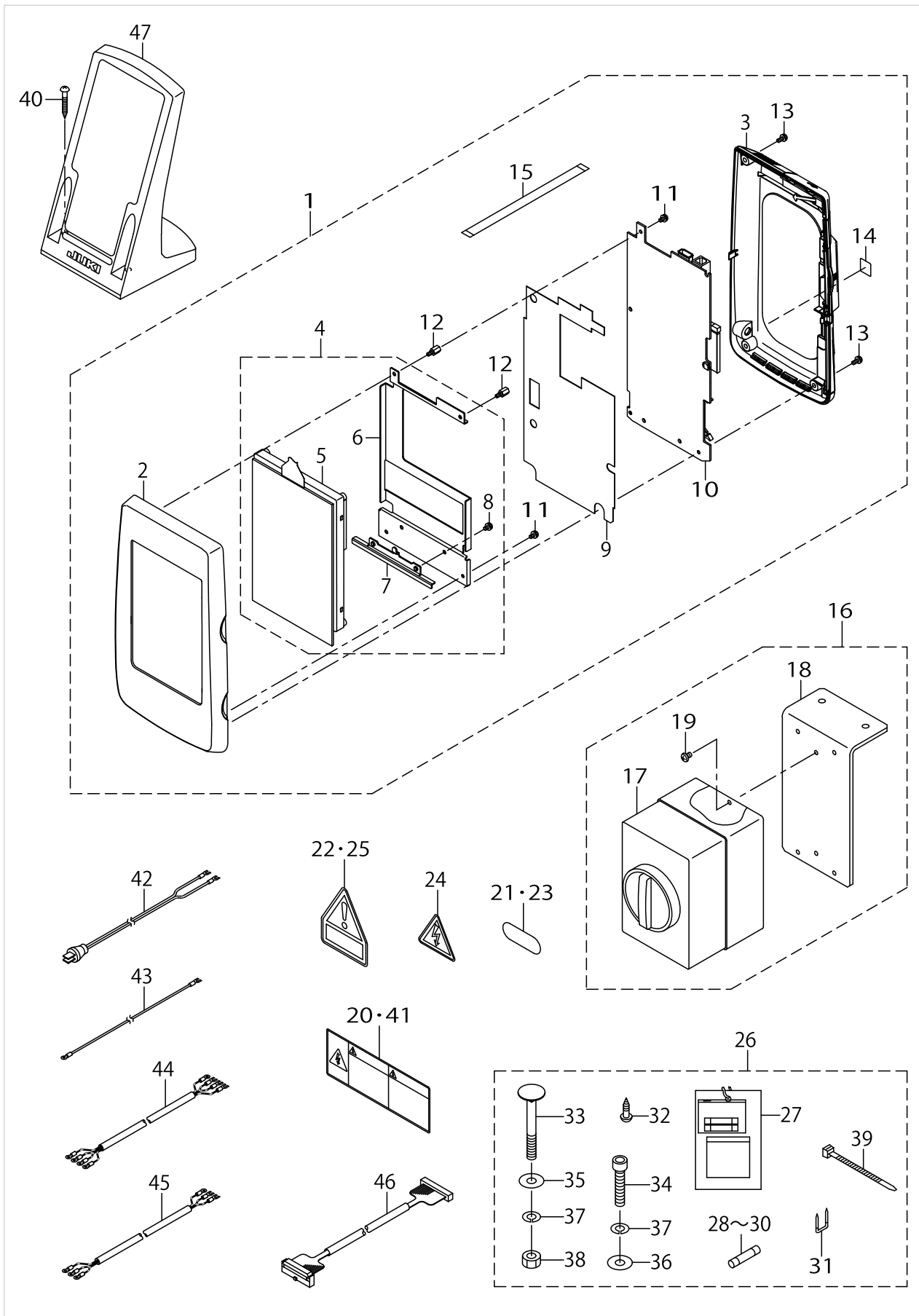

OPERATION PANEL COMPONENTS

No.	Parts No.	Parts name	Remarks	Level	Cons	Qty
1	40086485	IP-420F PANEL ASSY				1
2	40078163	FRONT_CASE		*		1
3	40080799	REAR_CASE_ASSY		*		1
4	40080800	LCD_ASSY		*		1
5	40086541	LCD TOUCH PANEL ASSY	TECHNICAL INFOMATION (A16-029)	*		1
6	40083668	LCD_BRACKET	TECHNICAL INFOMATION (A16-029)	*		1
7	40083666	LCD_STAY		*		1
8	SL4030681SC	SCREW M3 L=6		*		2
9	40078168	INSULATION_SHEET		*		1
10	40083960	PANEL PCB ASSY		*		1
11	SL4030681SC	SCREW M3 L=6		*		3
12	HX00354000B	PCB SUPPORT L=8MM		*		2
13	SL4030881SC	SCREW M3X8		*		4
14	CM600100101	WEEE MARK LABEL S		*		1
15	HW002180200	FLAT CABLE		*		1
16	40081602	POWER SWITCH ASM				1
17	HA005820000	SWITCH		*		1
18	40081603	SWITCH INSTALLATION BOARD		*		1
19	SL4041091SE	SCREW M4 L=10		*		2
20	CM300100401	LABEL 3 (LARGE)	FOR USE IN JAPAN(1-PHASE)			1
21	BME01100000	VOLTAGE INDICATION SEAL	FOR USE IN JAPAN(1-PHASE)			1
22	CM300400701	VOLTAGE CAUTION LABEL	FOR USE IN JAPAN,JA			1
23	BME03200000	VOLTAGE INDICATION SEAL	FOR USE IN JAPAN,JA			1
24	CM300100003	VOLTAGE WARNING LABEL(25)	FOR JE,GENERAL EXPORT			1
25	CM300400601	VOLTAGE CAUTION LABEL	FOR JE,GENERAL EXPORT			1
26	40085316	OPTION A ASSY				1
27	M300451100A	VOLTAGE INDICATION CARD A		*		1
28	HF00130315S	FUSE 3.15A 250V REF. NO.112		*		1
29	HF003000200	FUSE 2A (220/240V)		*		1
30	HF0013050P0	FUSE 5A		*		1
31	MA011532000	STAPLE		*		5
32	SK3512001SE	WOOD SCREW D=5.1 L=20		*		2
33	MTSHJ100003	BOLT		*		2
34	SM6084002TN	SCREW M8 L=40		*		1
35	WP0852086SC	WASHER M8		*		2
36	WP0841601SC	WASHER 8.4X17.4X1.6		*		1
37	WS0820002KR	SPRING WASHER M8		*		3
38	NM6080002SC	NUT M8		*		2
39	HX00065000A	CABLE CLIP		*		2
40	SK3413201SE	WOOD SCREW D=4.1 L=32				2
41	CM300100401	LABEL 3 (LARGE)	FOR USE IN JAPAN,JA			1
42	40086468	POWER CABLE 1P PLUG ASSY	FOR USE IN JAPAN(1-PHASE)			1
43	M90345800A0	GROUND CORD ASM.	FOR USE IN JAPAN(1-PHASE)			1
44	40086469	POWER CABLE 3P ASSY	FOR USE IN JAPAN,JA			1
45	40086470	POWER CABLE 1P ASSY	FOR JE,GENERAL EXPORT			1
46	40065566	PANEL CABLE D ASM				1
47	40035024	OPERATION_BOX_FIXED_PLATE(B)ASM				1

CONTROL BOX COMPONENTS

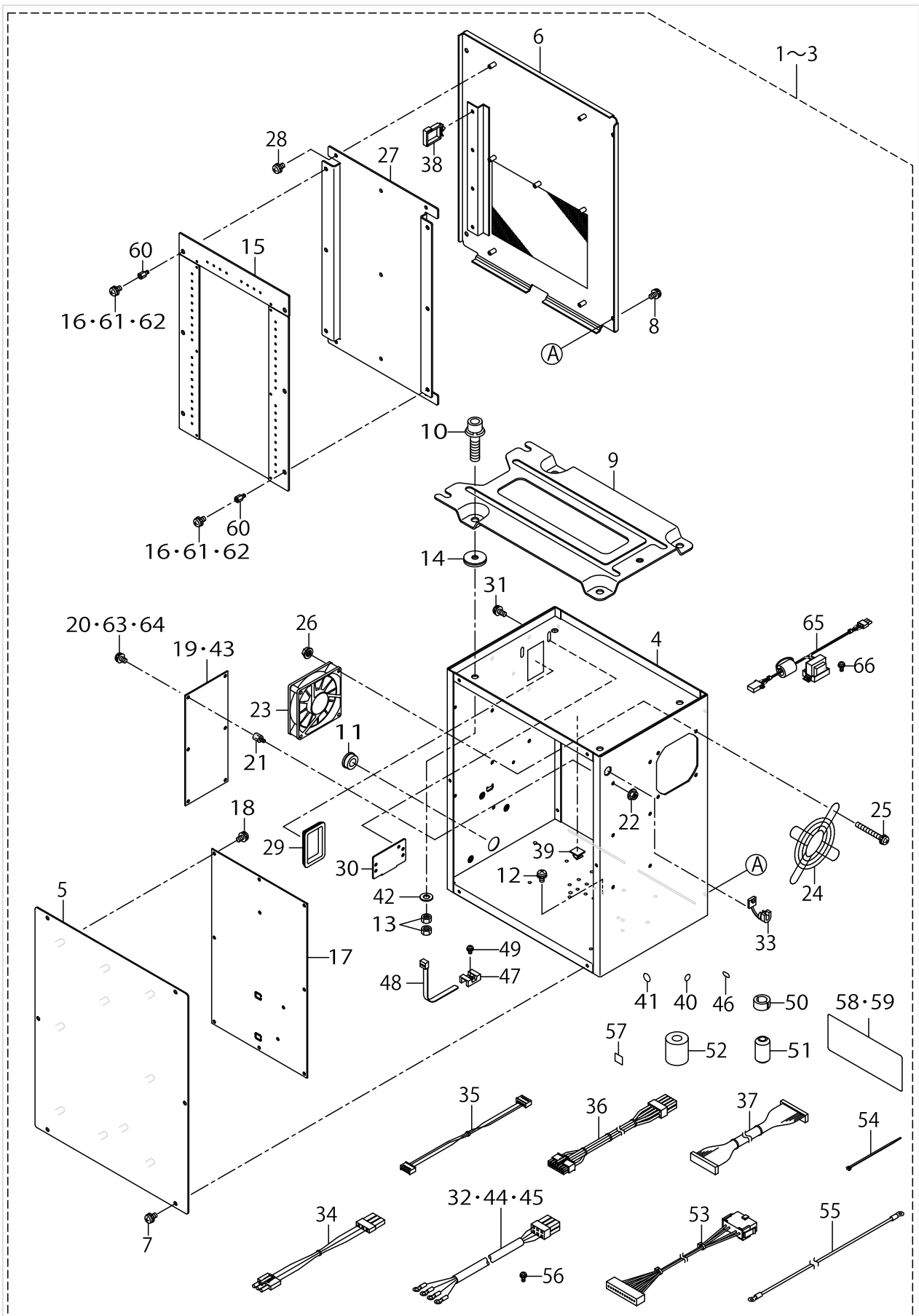

CONTROL BOX COMPONENTS

No.	Parts No.	Parts name	Remarks	Level	Cons	Qty
1	40081621	MC-588 BOX A	FOR MC-588 BOX A			1
2	40081622	MC-588 BOX B				1
3	40081623	MC-588 BOX C				1
4	40055355	CONTROL BOX		*		1
5	40094018	CONTROL BOX FRONT COVER		*		1
6	40094019	CONTROL BOX REAR COVER		*		1
7	SL4040891SC	SCREW M4 L=8		*		6
8	SL4040891SC	SCREW M4 L=8		*		4
9	M3801476000	TRANSMISSION BOX FITTING PLATE		*		1
10	SL6083092TN	SCREW		*		4
11	HX00326000K	GROMMET		*		1
12	SL4040891SC	SCREW M4 L=8		*		4
13	NM6080001SC	NUT M8X1.25		*		8
14	M4206461000	WASHER		*		4
15	40081590	MAIN PCB B ASSY		*		1
16	SL4040881SC	SCREW M4 L=8		*		6
17	40082758	SDC PCB A ASSY		*		1
18	SL4040881SC	SCREW M4 L=8		*		10
19	40000056	FLT-T PCB A ASS'Y	FOR MC-588 BOX A	*		1
20	SL4040881SC	SCREW M4 L=8		*		6
21	HX003390000	STUD		*		6
22	NM3040520SC	NUT M4		*		6
23	40005401	FAN MOTOR ASS'Y		*		1
24	KM000000480	FAN MOTOR		*		1
25	SL4043591SC	SCREW		*		4
26	NM3040520SC	NUT M4		*		4
27	40005706	MAIN PCB HOLDER PLATE		*		1
28	SL4040881SC	SCREW M4 L=8		*		5
29	HX004070000	BUSH		*		1
30	17845009	CORD FITTING PLATE		*		1
31	SL4041091SC	SCREW M4 L=10		*		2
32	40086465	POWER CORD 3P ASSY	FOR MC-588 BOX A	*		1
33	HX00410000A	STRAIN RELIEF BUSHING		*		1
34	40005393	FLT-SDC CORD P ASS'Y		*		1
35	40005394	FLT-SDC CORD S ASS'Y		*		1
36	40005726	SDC-MAIN CORD P ASS'Y		*		1
37	40005727	SDC-MAIN CORD S ASS'Y		*		1
38	HX005110000	WIRE SADDLE		*		3
39	E9607603000	STICKER (SMALL)		*		1
40	E9567319000	EARTH MARK		*		1
41	40003458	MASK SEAL		*		15
42	WP0841601SC	WASHER 8.4X17.4X1.6		*		4
43	40162838	FLT-CE PCB A ASSY		*		1
44	40086466	POWER CORD JE ASSY		*		1
45	40086467	POWER CORD 1P ASSY		*		1
46	CM200100001	PE MARK LABEL		*		1
47	KX000000210	SADDLE TYPE TIE MOUNT		*		1

CONTROL BOX COMPONENTS

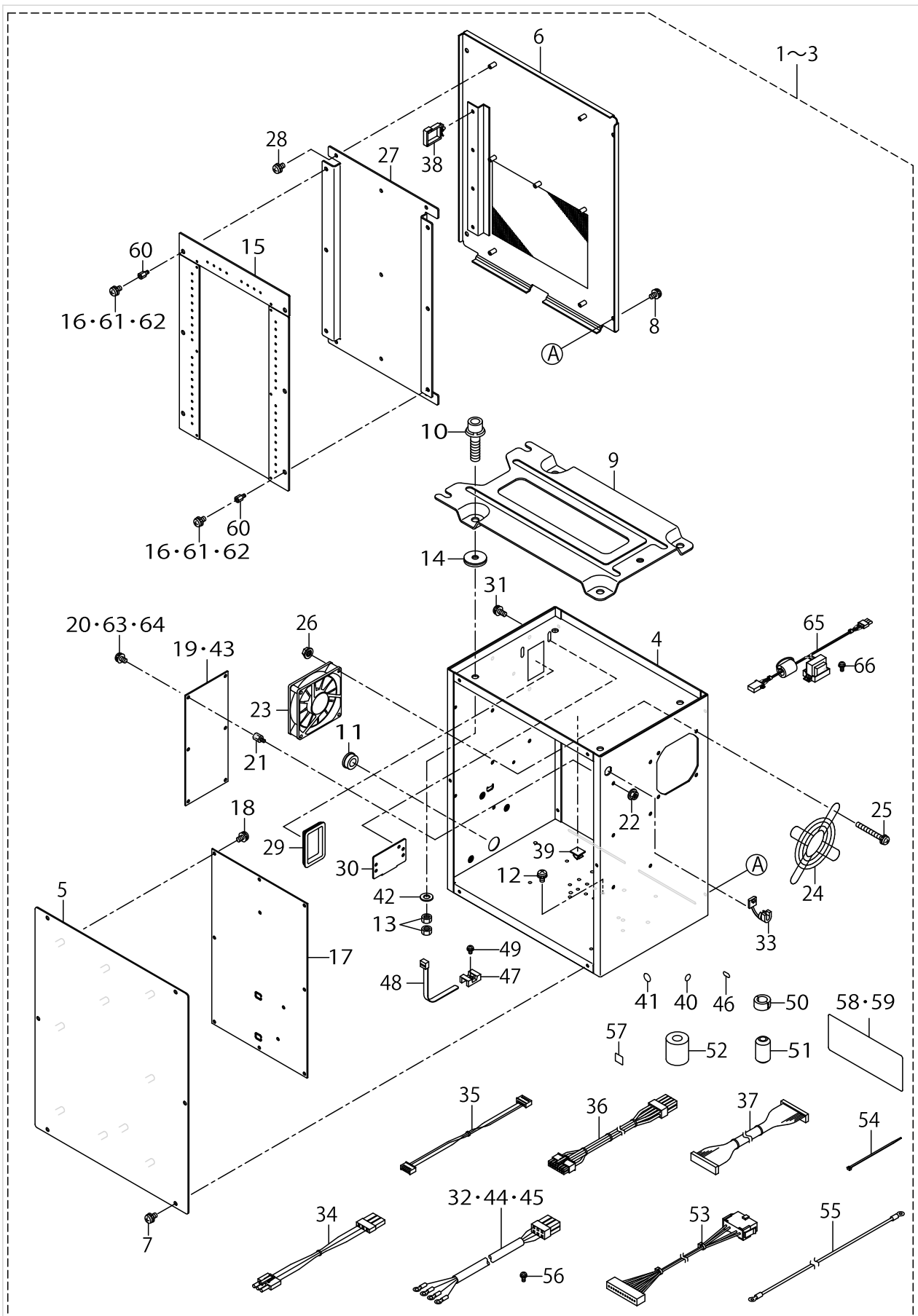

CONTROL BOX COMPONENTS

No.	Parts No.	Parts name	Remarks	Level	Cons	Qty
48	KX000000230	RELEASIBLE CABLE TIE		*		1
49	SL4040881SC	SCREW M4 L=8		*		1
50	HN002460000	CORES		*		1
51	HN002840000	CORES		*		1
52	HN001490000	CLAMP FILTER(L)		*		1
53	40073659	SW RELAY CORD ASM		*		1
54	EA9500B0100	CABLE BAND		*		1
55	M90295800A0	FDD EARTH CORD ASM.		*		1
56	SL4041081SC	SCREW M4 L=10		*		1
57	CM600100101	WEEE MARK LABEL S		*		1
58	40051640	ELECTRICAL_RATING_LABEL_UNIVERSAL		*		1
59	40057278	ELECTRICAL_RATING_LABEL_CE_UNIVERSAL		*		1
60	HX00339000M	SPACER		*		5
61	SL4040881SC	SCREW M4 L=8		*		1
62	SL4041091SC	SCREW M4 L=10		*		5
63	SL4040881SC	SCREW M4 L=8		*		5
64	SL4041081SC	SCREW M4 L=10		*		1
65	40163025	REACTOR CORD ASSY		*		1
66	SL4040891SC	SCREW M4 L=8		*		2

WIRING DIAGRAM

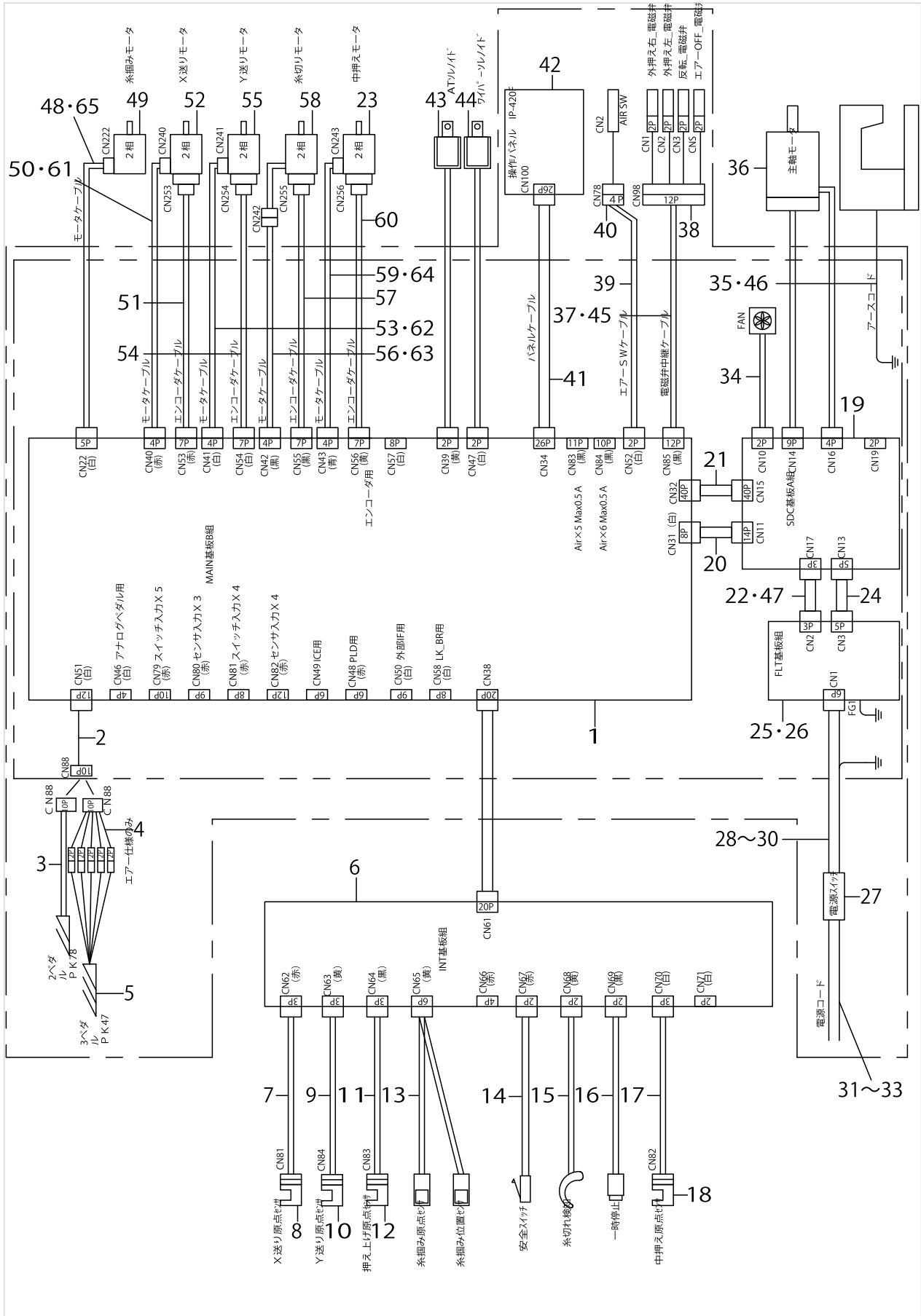

WIRING DIAGRAM

No.	Parts No.	Parts name	Remarks	Level	Cons	Qty
1	40081590	MAIN PCB B ASSY				1
2	40073659	SW RELAY CORD ASM				1
3	40033831	PK78 PEDAL SWITCH ASM				1
4	40033875	PK47 RELAY CABLE ASM				1
5	GPK470010AB	3-PEDAL ASM.				1
6	40040230	INT PCB ASM				1
7	40040222	X SENSOR CABLE ASM				1
8	HD00057000A	PHOTO SENSOR				1
9	40040223	Y SENSOR CABLE ASM				1
10	HD00057000A	PHOTO SENSOR				1
11	40040238	PF_SENSOR_CABLE_ASM				1
12	HD00057000A	PHOTO SENSOR				1
13	40040224	TH SENSOR ASM				1
14	40029633	SAFETY SW CORD ASM				1
15	40040225	THB SENSOR CABLE ASM				1
16	40040242	STOP SW ASM				1
17	40040240	IP SENSOR CABLE ASM				1
18	HD00057000A	PHOTO SENSOR				1
19	40082758	SDC PCB A ASSY				1
20	40005726	SDC-MAIN CORD P ASSY				1
21	40005727	SDC-MAIN CORD S ASSY				1
22	40005393	FLT-SDC CORD P ASS'Y				1
23	40102213	ENCODER MOTOR ASM				1
24	40005394	FLT-SDC CORD S ASS'Y				1
25	40000056	FLT-T PCB A ASS'Y				1
26	40162838	FLT-CE PCB A ASSY				1
27	40081602	POWER SWITCH ASM				1
28	40086465	POWER CORD 3P ASSY				1
29	40086466	POWER CORD JE ASSY	FOR JE			1
30	40086467	POWER CORD 1P ASSY				1
31	40086468	POWER CABLE 1P PLUG ASSY				1
32	40086469	POWER CABLE 3P ASSY				1
33	40086470	POWER CABLE 1P ASSY				1
34	40005401	FAN MOTOR ASS'Y				1
35	40005712	EARTH CODE ASM				1
36	40052937	550W_SERVO_MOTOR				1
37	40081601	AIR RELAY CABLE ASM				1
38	40048529	VALVE RERAY COAD ASM				1
39	40093109	AIR SW CABLE ASM				1
40	40030951	FILTER_REGULATOR_ASM.				1
41	40065566	PANEL CABLE D ASM				1
42	40086485	IP-420F PANEL ASSY				1
43	40073660	AT SOLENOID				1
44	40086363	WIPER_ASM				1
45	40163061	AIR RELAY CABLE ASM	FOR JE			1
46	M90195800A0	EARTH CABLE ASM.	FOR JE			1
47	40163025	REACTOR CORD ASSY	FOR JE			1

WIRING DIAGRAM

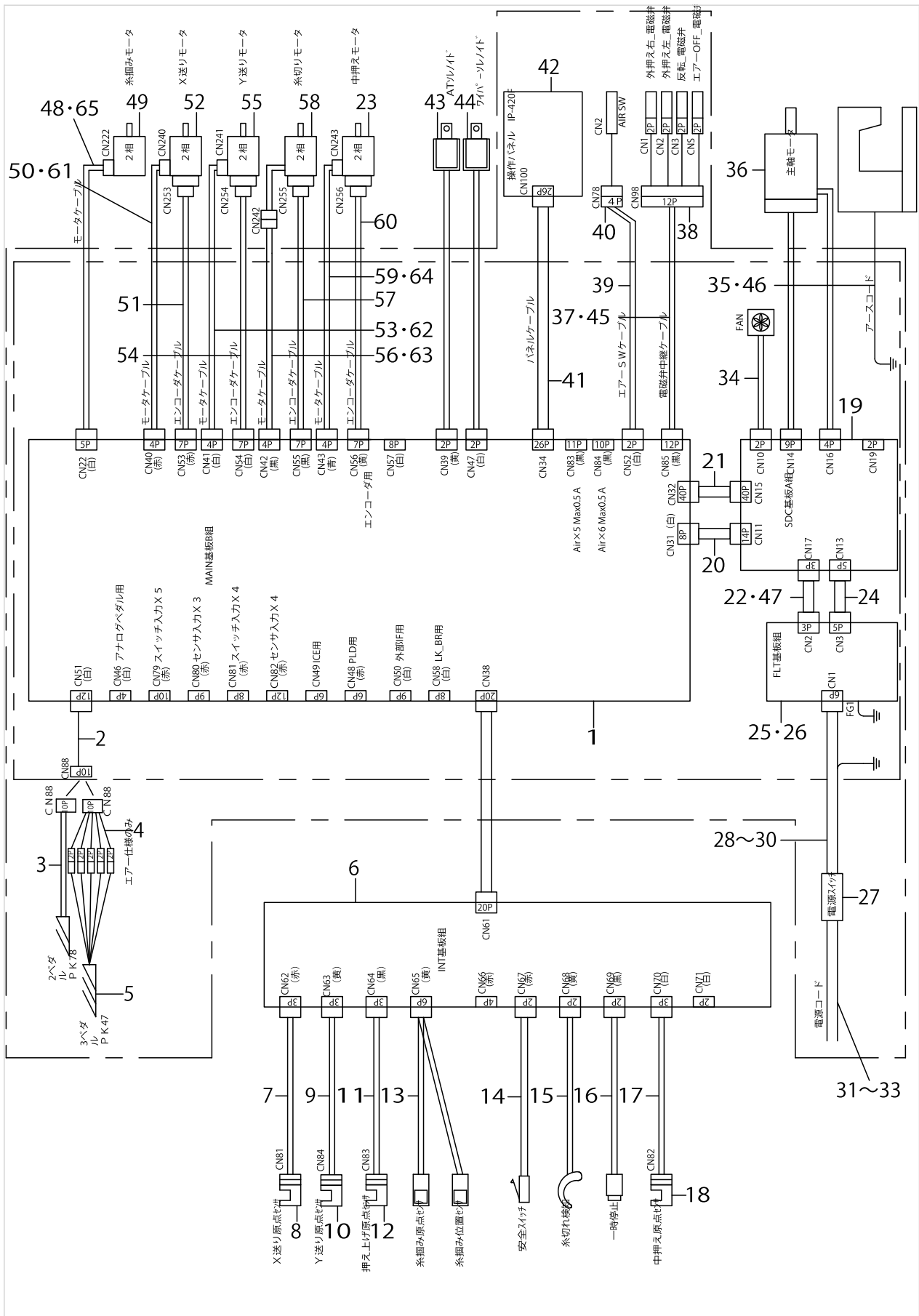

WIRING DIAGRAM

No.	Parts No.	Parts name	Remarks	Level	Cons	Qty
48	40083869	TH MOTOR CABLE ASM				1
49	40085033	STEPPING MOTOR				1
50	40083865	X MOTOR CABLE ASM				1
51	40083870	X ENCODER CABLE ASM				1
52	40071945	STEPPING MOTOR				1
53	40083866	Y MOTOR CABLE ASM				1
54	40083871	Y ENCODER CABLE ASM				1
55	40104419	ENCODER MOTOR ASM.(X-Y)				1
56	40083867	TT MOTOR CABLE ASM				1
57	40083872	TT ENCODER CABLE ASM				1
58	40103968	ENCODER MOTOR ASM.(TC)				1
59	40083868	IP MOTOR CABLE ASM				1
60	40083873	IP ENCODER CABLE ASM				1
61	40163089	X MOTOR CABLE ASM	FOR JE			1
62	40163090	Y MOTOR CABLE ASM	FOR JE			1
63	40163091	TT MOTOR CABLE ASM	FOR JE			1
64	40163092	IP MOTOR CABLE ASM	FOR JE			1
65	40178385	TH MOTOR CABLE ASM CE	FOR JE			1

PEDAL COMPONENTS

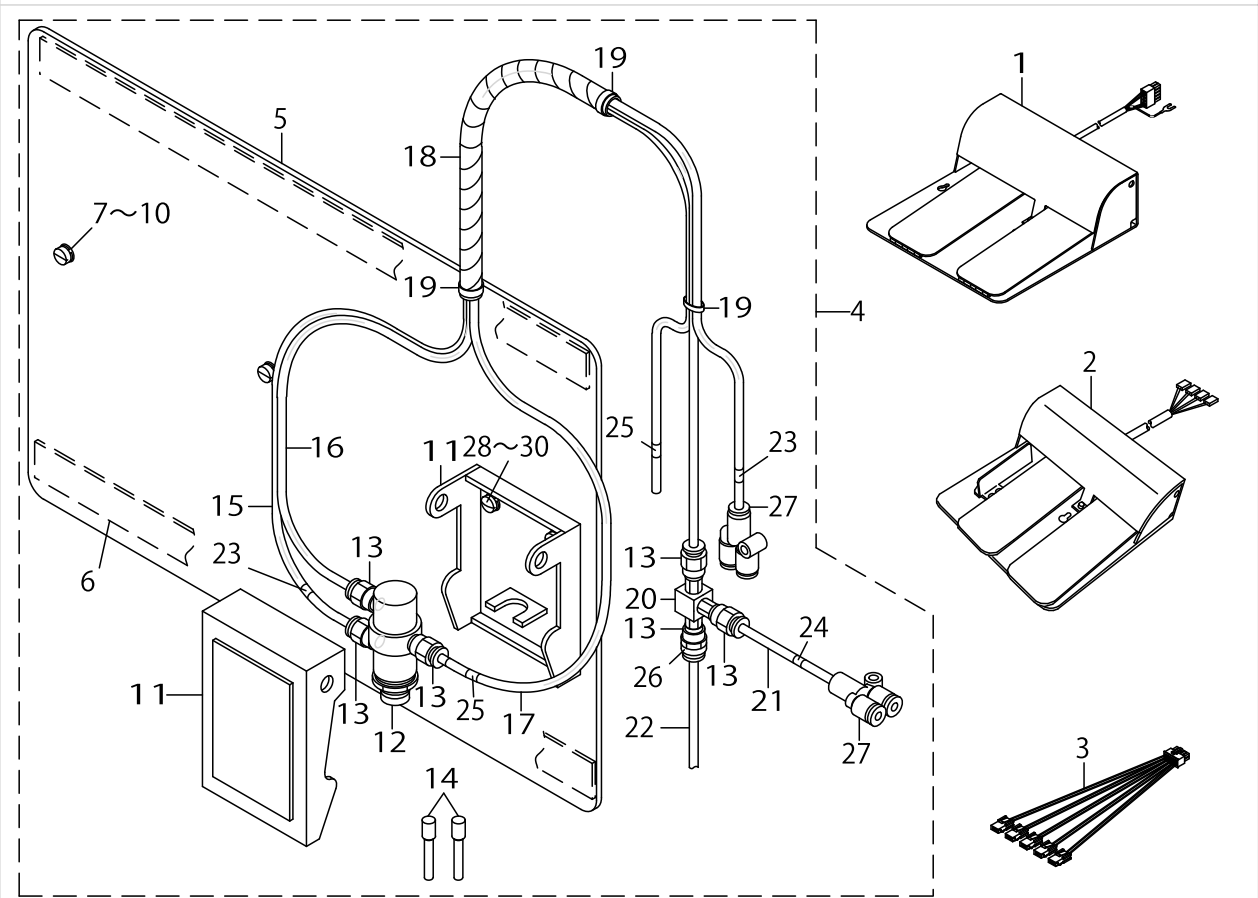

PEDAL COMPONENTS

No.	Parts No.	Parts name	Remarks	Level	Cons	Qty
1	40033831	PK78 PEDAL SWITCH ASM.	FOR AMS-221ENHS, AMS-221EN-3020			1
2	GPK470010AB	3-PEDAL ASM.				1
3	40033875	PK47 RELAY CABLE ASM.				1
4	40042352	MECHANICAL VALVE UNIT	FOR AMS-221ENHS, AMS-221EN-3020			1
5	D8001D15A0Y	PEDAL BASE		*		1
6	D8002D15A0Y	PEDAL CUSHION		*		2
7	SS6111210SP	SCREW 11/64-40 L=12		*		2
8	WP0450801SD	WASHER 4.5X10X0.8		*		2
9	WS0451040KP	SPRING WASHER 4.5X8.5X1		*		2
10	WP0553216SD	WASHER		*		2
11	PX020002000	ACTUATOR		*		1
12	PV010502000	AIR VALVE		*		1
13	PJ301040501	HALF UNION M5 D=4		*		6
14	PX500014000	PLUG		*		2
15	BT0400251EB	URETHANE HOSE BLACK		*		1.9
16	BT0400251EB	URETHANE HOSE BLACK		*		1.8
17	BT0400251EB	URETHANE HOSE BLACK		*		1.9
18	HX00314000A	SPIRAL TUBE		*		0.6
19	EA9500B0100	CABLE BAND		*		3
20	GEP01013000	VALVE		*		1
21	BT0400251EB	URETHANE HOSE BLACK		*		0.1
22	BT0400251EB	URETHANE HOSE BLACK		*		0.1
23	18035204	WIRE MARK (3)		*		2
24	18035303	WIRE MARK (4)		*		1
25	18035600	WIRE MARK (7)		*		2
26	18035709	WIRE MARK (8)		*		1
27	PJ308040002	QUICK COUPLING		*		2
28	WP0450801SD	WASHER 4.5X10X0.8		*		2
29	WS0451040KP	SPRING WASHER 4.5X8.5X1		*		2
30	SS7111120TP	SCREW		*		2

ACCESSORIE PART COMPONENTS

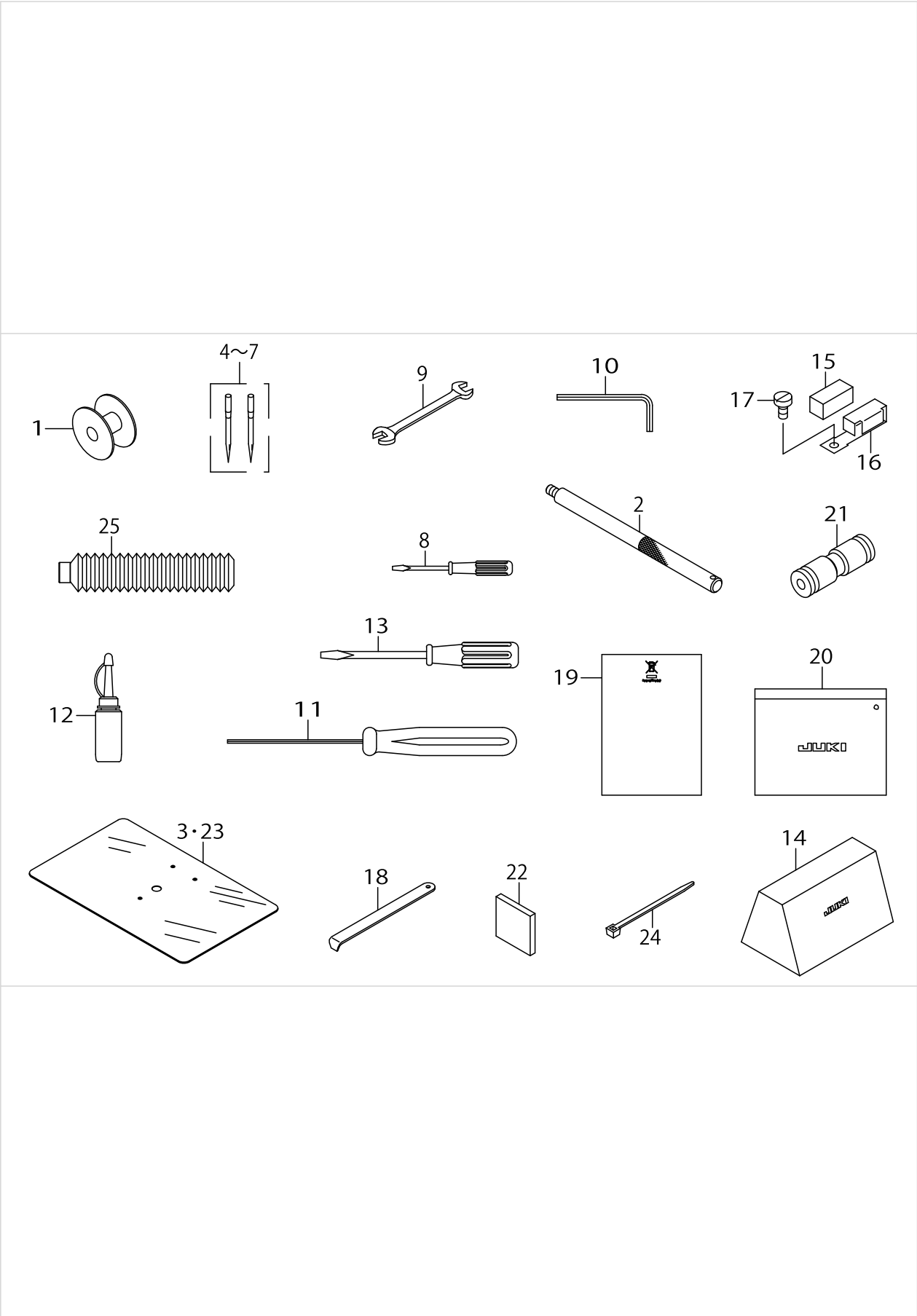

ACCESSORIE PART COMPONENTS

No.	Parts No.	Parts name	Remarks	Level	Cons	Qty
1	B1806210D00	BOBBIN				1
2	40044920	HEAD GRIP				1
3	B1170221D00	NEEDLE PLATE COVER SHEET				1
4	MDP500B1402	NEEDLE DPX5#14-2	TYPE S (FOR ST)		☆	1
5	MDP170B1802	NEEDLE DPX17#18-2			☆	1
6	MC200501002	NEEDLE 134 #100-2			☆	1
7	MC372001102	NEEDLE SY3355 #110-2			☆	1
8	22933204	SCREW DRIVER SMALL				1
9	B9113012000	WRENCH (9X10)				1
10	B9140372000	HEXAGONAL WRENCH SMALL				1
11	40032763	HEXAGONAL_DRIVER(1.5)				1
12	B91212200A0	OILER (CONTAINING NO.2 OIL)				1
13	22933105	SCREW DRIVER MIDDLE				1
14	40027770	VINYL COVER				1
15	B1131528000	FELT				1
16	10102200	THREAD GUIDE F				1
17	SM6040860TP	SCREW M4 L=8				1
18	B9101490000	DRIVER				1
19	CM600100201	WEEE INFORMATION SHEET				1
20	22932800	ACCESSORIE BAG				1
21	PJ303040002	STRAIGHT UNION				4
22	40050647	CF CARD SET AMS-221E				1
23	40033185	COVER_SEET				1
24	EA9500B0100	CABLE BAND				1
25	40097886	GREASE				1

OPTIONAL PARTS

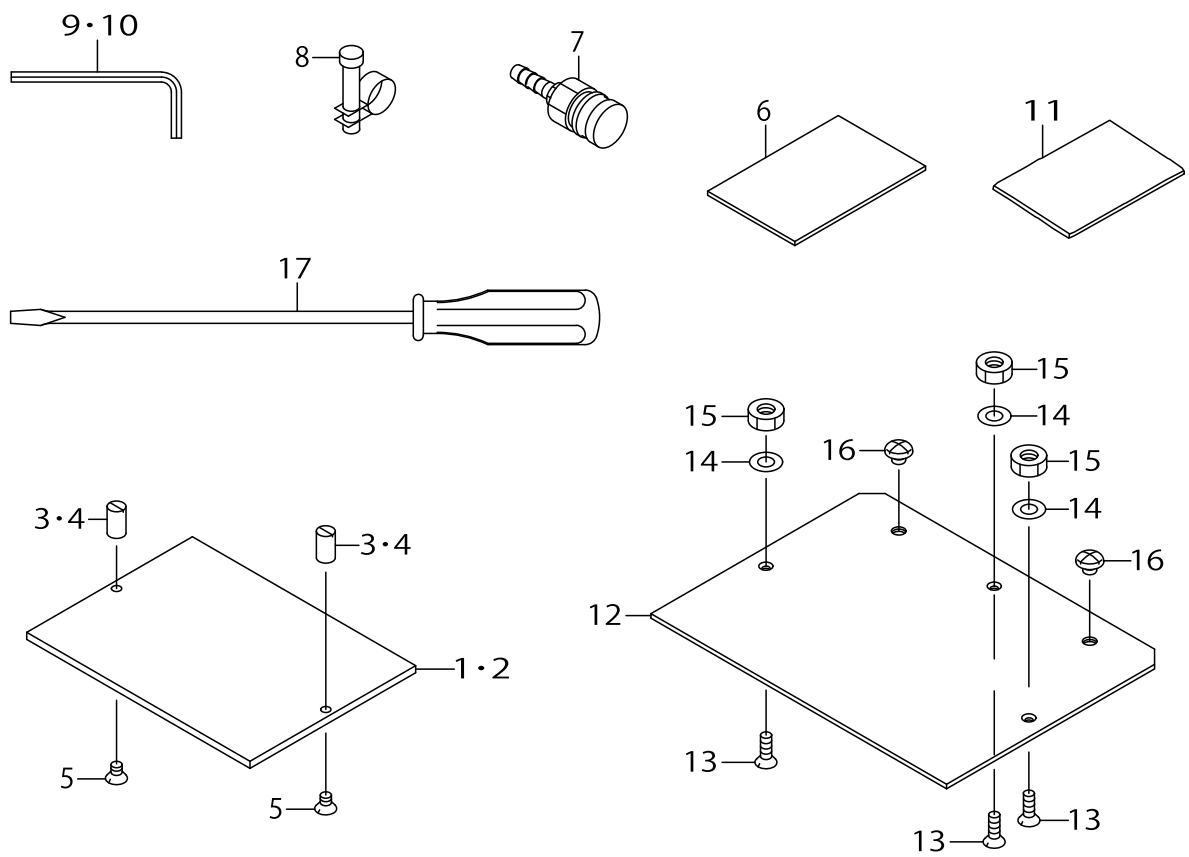

OPTIONAL PARTS

No.	Parts No.	Parts name	Remarks	Level	Cons	Qty
1	40035093	PLASTIC_BLANK_2516	FOR AMS-221ENHS			1
2	40035094	PLASTIC_BLANK_3020				1
3	40035092	INSTALLING_PIN	FOR AMS-221ENHS			2
4	40051836	INSTALLING_PIN				2
5	SM1040650TP	SCREW				2
6	B2564223C00	SPONGE				1
7	PJ309520001	SOCKET				1
8	PB000010000	HOSE BAND				1
9	B9141372000	HEXAGONAL WRENCH LARGE				1
10	GCT02906000	HEXAGONAL SPANNER				1
11	B2591220000	RUBBER SHEET				1
12	40035095	PLASTIC_BLANK_2516L				4
13	SM1041201SC	SCREW M4 L=12				6
14	WP0430801SC	WASHER 4.3X9X0.8				6
15	NM6040001SC	NUT M4				6
16	SM4040455SP	SCREW				4
17	22933006	SCREW DRIVER LARGE				1

HOW TO MAKE USE OF THIS PARTS LIST

1.Explanation of codes

1)"*"mark.....means this part is changed from the previous parts book.

As to the details of the change, refer to the "List for information of change".

2)"#01".....refer to "Note" explanation at bottom of page.

2.Codes on the "Qty" column

- Each numeral indicates the number of parts required.
- "0.1" and "2.5" indicate the length (in meters) of the respective parts.

3.Parentheses mean that the corresponding part is a subpart that constructs an assembly part.

4.Dotted lines on the Figures indicate assembly parts.

5.As to the parts with marks of "☆"(consumable parts) and "◎"(optional parts)on the respective parts, it is recommended to prepare spares.

1 ."注記"欄の記号説明

1) "*"印.....前回のパーツブックに比較して今回変更された部品を意味します。

変更内容は、"変更情報リスト"を参照してください。

2) "#01".....ページ下の"注記"の説明を参照してください。

2.数量欄の数字は、個数を表し、0.1、2.5等の数値は、長さ（単位メートル）を表します。

3.数量欄の（ ）は、組部品を構成している子部品であることを意味します。

4.イラストページの-----枠は、組構成であることを意味します。

5.リストページの"☆"（消耗部品）、"◎"（オプション部品）の印がついた部品は、予備を準備しておくことをお奨めします。

NUMERICAL INDEX OF PARTS

PART NO	PAGE	REF NO.	PART NO	PAGE	REF NO.	PART NO	PAGE	REF NO.
10102200	80	16	22933006	82	17	40005393	70	34
10108009	16	22	22933105	80	13	40005393	74	22·47
10502300	2	35	22933204	80	8	40005394	70	35
10523702	60	42	22955504	32	35	40005394	74	24
11072402	6	29	22955900	32	7	40005401	70	23
11155108	60	17	22956007	32	8	40005401	74	34
11155207	60	18	22956908	32	14	40005706	70	27
11158300	60	5	23517501	38	4~7	40005712	6	35
11158409	60	6	23517600	38	4~7	40005712	74	35·46
11158516	60	7	23517709	38	4~7	40005726	70	36
11272408	50	18	23517808	38	4~7	40005726	74	20
13122403	20	23	23604200	16	2	40005727	70	37
13122452	20	22	23604309	16	42	40005727	74	21
13529607	28	26	23610108	20	39	40006317	28	9
13705108	2	21	23630007	28	25	40006323	4	53·54
13816855	10	12	23638109	10	39	40006484	2	39
13888201	60	47	23638208	10	41	40006497	10	40
14103352	28	39	23638406	10	42	40006515	18	50
14103907	28	21	26017707	54	5	40006516	18	52
14104004	28	19	26023408	54	7	40006530	18	65
14113450	6	31	26211904	2	12	40006531	18	66
14113468	6	28	26218602	34	31	40006532	18	74
16870206	60	32	26221101	10	15	40006555	16	17
16992604	50	19	26221200	10	14	40006561	16	23
17007402	60	8	26226001	24	42	40006567	28	5
17833658	60	9	26226506	60	46	40006569	28	6
17845009	70	30	26260109	6	5	40006576	28	31
18035204	78	23	26260208	6	6	40006577	28	22
18035303	78	24	26260307	6	7	40006578	28	45
18035600	78	25	26260406	6	8	40006617	34	5
18035709	78	26	26260505	6	9	40006622	34	25
22687701	50	21	26260604	6	10	40006625	34	4
22891006	18	73	26260703	6	11	40006666	40	54
22891204	16	28	26260802	6	12	40006761	42	1
22901409	18	62	26261206	6	16	40006780	42	11
22901805	6	3	26261305	6	17	40006836	10	34
22902506	2	4	26261503	6	18	40006840	10	36
22907505	20	45	26261602	6	19	40010405	2	29
22907554	20	44	26261701	6	20	40010414	2	10
22907604	20	46	26501858	28	18	40010415	16	5
22920508	2	16	31262801	10	13	40010418	16	7
22921506	34	29	40000056	70	19·43	40010421	16	20
22921605	34	42·46	40000056	74	25·26	40010422	16	9
22928808	34	28	40003458	70	41	40010423	16	10
22932800	80	20	40003970	24	46	40010424	16	11

NUMERICAL INDEX OF PARTS

PART NO	PAGE	REF NO.	PART NO	PAGE	REF NO.	PART NO	PAGE	REF NO.
40010425	16	12	40014964	30	41·49·68	40026979	2	3
40010426	16	13	40014965	30	41·49·68	40027770	80	14
40010427	16	14	40015800	42	5	40027870	24	37
40010434	16	33	40016705	62	72	40027971	2	37
40010437	16	36	40023624	22	60	40028338	6	4
40010438	16	37	40023624	38	13	40028834	2	47
40010439	16	38	40023631	22	49	40028835	4	48
40010440	16	39	40023632	22	50	40028877	2	28
40010443	38	18	40023635	54	52	40029411	34	32·33
40010464	28	2	40023635	56	52	40029412	34	42·46
40010471	28	28	40023644	54	3	40029419	20	36
40010472	28	30	40023662	64	29	40029420	24	5
40010477	34	6	40023865	6	13	40029633	10	45
40010478	34	41	40023866	6	14	40029633	74	14
40010479	34	8	40023993	34	12	40030615	24	15
40010487	34	17	40024063	28	7	40030616	22	62
40010489	34	23	40024988	20	29	40030617	20	4
40010490	34	20	40024989	24	24	40030620	20	31
40010497	34	21	40024991	20	40	40030621	22	55
40010498	34	22	40024997	10	9	40030623	20	47
40010503	34	27	40024999	2	6	40030625	24	1
40010504	34	30	40025011	20	13	40030626	24	2
40010508	34	32·33	40025012	20	5	40030627	24	3
40010509	34	34	40025016	24	31	40030628	22	63~65
40010510	34	35	40025030	24	36	40030629	22	63~65
40010511	34	36	40025414	2	14	40030630	22	63~65
40010512	34	37	40025415	20	8	40030828	2	8
40010513	34	38	40025418	24	33	40030829	6	15
40010514	34	39	40025419	26	48	40030932	38	23~25
40010515	34	40	40025420	24	44	40030933	38	23~25
40010521	34	43	40025423	24	8	40030934	38	45
40010522	34	44	40025426	24	27	40030936	38	1
40010523	34	45	40025427	20	2	40030942	42	17
40010527	42	22	40025428	20	11	40030943	42	15
40010528	42	23	40025429	20	26	40030950	64	15
40010533	18	54	40025431	20	1	40030951	64	17
40010590	42	10	40025440	32	36	40030951	74	40
40011152	42	24	40026817	24	4	40030956	32	6
40011205	62	62	40026818	16	24	40031336	4	52
40011926	60	39	40026819	24	9	40032158	2	1
40012815	42	19	40026829	10	30	40032159	2	26
40012965	20	19	40026830	10	31	40032161	12	53
40013640	4	53·54	40026831	10	32	40032162	14	1
40013967	36	48	40026882	18	57	40032163	14	3
40014963	28	40	40026884	18	60·61	40032167	14	8

NUMERICAL INDEX OF PARTS

PART NO	PAGE	REF NO.	PART NO	PAGE	REF NO.	PART NO	PAGE	REF NO.
40032168	14	2	40032837	58	22	40040230	10	47
40032173	10	18	40032838	58	23	40040230	74	6
40032174	12	61	40032839	58	14	40040238	74	11
40032175	16	8	40032840	58	15	40040240	26	52
40032176	14	28·34	40032842	58	3	40040240	74	17
40032177	14	28·34	40032843	58	40	40040242	2	33
40032178	14	29·35	40032844	58	7	40040242	74	16
40032179	24	7	40033069	42	39	40040256	38	8
40032180	24	17	40033182	10	37	40042352	78	4
40032181	24	23	40033183	10	38	40043096	52	62
40032182	30	67	40033185	80	3·23	40043098	46	42
40032184	30	59	40033186	14	5	40043321	26	55
40032185	30	57	40033831	74	3	40043869	28	1
40032186	38	15	40033831	78	1	40044053	16	46
40032187	42	26	40033875	74	4	40044186	54	1·2
40032190	34	26	40033875	78	3	40044329	58	33
40032191	52	58	40034185	54	38	40044920	80	2
40032192	50	3	40034186	54	40	40048529	74	38
40032197	50	7	40034568	54	1·2	40050509	4	49
40032200	48	1·50	40034846	28	12	40050647	80	22
40032203	50	9	40035024	68	47	40051499	12	59
40032205	46	3	40035092	82	3·4	40051500	58	34
40032209	46	37	40035093	82	1·2	40051501	12	51
40032210	50	13	40035094	82	1·2	40051502	12	60
40032215	50	16	40035095	82	12	40051536	62	91
40032216	50	17	40035160	42	34	40051640	72	58·59
40032217	46	6	40035161	42	28	40051769	58	43
40032218	46	25	40035705	14	4	40051770	58	37
40032219	46	10	40036110	4	55	40051782	58	45
40032221	50	23	40036117	28	37	40051836	82	3·4
40032223	46	40	40036118	28	47	40051987	2	40
40032226	58	1	40037500	32	32	40052937	16	40
40032229	54	16	40037501	32	33	40052937	74	36
40032230	54	17	40039546	10	68	40055355	70	4
40032231	56	57	40039546	12	68	40057278	72	58·59
40032232	64	1	40039547	10	67	40057368	50	4
40032233	64	6	40039547	12	67	40057370	50	5
40032238	46	23	40040082	42	43	40057371	50	6
40032239	46	4	40040222	46	29	40057380	12	52
40032240	46	35	40040222	74	7	40061991	28	41·49·68
40032343	34	11	40040223	74	9	40065566	68	46
40032483	24	6	40040224	42	33	40065566	74	41
40032763	80	11	40040224	74	13	40068833	20	14
40032835	58	19	40040225	2	45	40068834	20	28
40032836	58	20	40040225	74	15	40068835	20	7

NUMERICAL INDEX OF PARTS

PART NO	PAGE	REF NO.	PART NO	PAGE	REF NO.	PART NO	PAGE	REF NO.
40071945	76	52	40082758	74	19	40086465	70	32·44·45
40072009	28	4	40083666	68	7	40086465	74	28~30
40072211	38	19	40083668	68	6	40086466	70	32·44·45
40072228	38	10	40083865	76	50·61	40086466	74	28~30
40073081	24	47	40083866	76	53·62	40086467	70	32·44·45
40073082	46	28	40083867	76	56·63	40086467	74	28~30
40073085	38	23~25	40083868	76	59·64	40086468	68	42
40073659	72	53	40083869	76	48·65	40086468	74	31~33
40073659	74	2	40083870	76	51	40086469	68	44
40073660	34	1	40083871	76	54	40086469	74	31~33
40073660	74	43	40083872	76	57	40086470	68	45
40076232	42	16	40083873	76	60	40086470	74	31~33
40076233	42	3	40083960	68	10	40086485	68	1
40076236	42	12	40084115	2	31	40086485	74	42
40076237	42	9	40085033	42	30	40086541	68	5
40076238	42	4	40085033	76	49	40089365	28	13
40076239	42	14	40085316	68	26	40089367	16	16
40076294	32	41	40085784	66	2	40089777	46	2
40077604	18	55	40085785	66	3	40089778	48	51
40077605	18	56	40085786	66	4	40089779	46	5
40078079	18	81	40085787	66	5	40089782	62	85
40078083	18	75	40085788	66	6	40089783	62	84
40078088	18	71	40085789	66	7	40089784	62	86
40078106	18	70	40085790	66	8	40089785	62	76
40078107	18	88	40085791	66	9	40089786	62	48
40078108	50	8	40085792	66	10	40089787	62	49
40078113	22	59	40085793	66	11	40089789	60	37
40078133	20	43	40085794	66	12	40089790	60	36
40078135	18	77·78	40085795	66	13	40089791	62	56
40078160	18	83	40085796	66	16	40089792	62	50
40078163	68	2	40086349	32	11	40089796	34	14
40078168	68	9	40086350	32	9	40089798	34	15
40078382	18	64	40086351	32	28	40089799	46	1·50
40080799	68	3	40086352	32	15	40090320	60	14·15
40080800	68	4	40086353	32	10	40090330	10	17
40081590	70	15	40086354	32	27	40090331	12	58
40081590	74	1	40086355	32	5	40090434	60	14·15
40081601	74	37·45	40086357	32	12	40091075	62	61
40081602	68	16	40086358	32	13	40091076	62	68
40081602	74	27	40086363	32	1	40091078	60	34
40081603	68	18	40086363	74	44	40091083	62	77
40081621	70	1~3	40086364	32	4	40091362	62	79
40081622	70	1~3	40086365	60	43	40091894	32	16
40081623	70	1~3	40086367	10	70	40093109	74	39
40082758	70	17	40086367	12	70	40093291	50	11

NUMERICAL INDEX OF PARTS

PART NO	PAGE	REF NO.	PART NO	PAGE	REF NO.	PART NO	PAGE	REF NO.
40094018	70	5	B1155221D00	14	6	B1908505000	18	67
40094019	70	6	B1156221D00	14	7	B2107210D00	32	2
40096092	22	58	B1157215000	14	13	B2107210D0B	32	42
40096186	18	77·78	B1170221D00	80	3·23	B2304205000	56	50
40096209	18	79·80	B1181221D00	14	9	B24142800A0	38	34
40096325	66	14	B1182221D00	14	10	B24152800A0	38	32
40096326	66	17	B1183221D00	14	11	B2416280000	38	31
40096327	66	19	B1193221D00	14	12	B2417210000	38	36
40096354	66	1	B1212210D00	16	44	B2417280000	38	38
40097886	80	25	B1223771000	62	87	B2418280000	38	30
40098325	60	33	B1405210000	18	60·61	B2421210AA0	38	29
40098326	62	70	B1408180000	20	32	B242328000A	38	41~44
40102213	24	20	B14115520A0	18	58	B242328000B	38	41~44
40102213	74	23	B1411804A00	30	53~56	B242328000C	38	41~44
40103968	40	49	B1411804B00	30	53~56	B242328000D	38	41~44
40103968	76	58	B1411804C00	30	53~56	B2424210000	38	46
40104419	50	61	B1411804D00	30	53~56	B242621000A	38	26~28
40104419	52	61	B1414555000	18	59	B242621000B	38	26~28
40104419	76	55	B1504210000	54	4	B242621000D	38	26~28
40105704	64	36	B1504221D00	14	29·35	B2504221D00	50	1
40121230	52	70	B151902600G	46	7	B2505221D00	50	2
40121232	50	15	B161121000A	22	48	B2513215000	58	17
40121671	50	14	B1625220000	56	51	B2516215000	56	54
40121766	52	71	B1628191B00	62	71	B2518215000	54	44
40121767	52	72	B1634210D00	22	53	B2518215A00	54	46
40150131	8	48	B1636581A00	20	15~18	B2525223C00	50	10
40162838	70	19·43	B1636581B00	20	15~18	B2527215000	54	45
40162838	74	25·26	B1636581C00	20	15~18	B2529232000	10	3
40163025	72	65	B1636581D00	20	15~18	B2530215000	56	59
40163025	74	22·47	B1641562000	24	41	B2534223C00	50	12
40163061	74	37·45	B1705850000	18	79·80	B2537221D00	50	40
40163089	76	50·61	B1802180000	50	22	B2539223C00	62	82
40163090	76	53·62	B1806210D00	28	43	B2548215000	56	58
40163091	76	56·63	B1806210D00	80	1	B2558220000	58	4
40163092	76	59·64	B1816215P00	40	48	B2560220000	58	41
40178385	76	48·65	B1816280000	46	8	B2564223C00	82	6
A1230500000A	18	48	B1816280000	54	21	B2567215000	58	12
B1111215000	10	1	B1816280000	58	24	B25672150A0	58	11
B1115215000	10	2	B1820210D00	28	14	B2568223C00	54	25
B1116215000	12	55	B1821210D00	28	15	B2576220000	54	6
B1129210000	2	19	B1822215P00	28	16	B25792290A0	54	32
B1131528000	80	15	B1828210DAA	28	42	B2591220000	82	11
B1132223C00	10	69	B1847221D00	30	52	B2613215000	58	9
B1132223C00	12	69	B185351200EA	56	55	B26132150A0	58	8
B1144210000	16	45	B1903552000	18	76	B3012816000	56	48

NUMERICAL INDEX OF PARTS

PART NO	PAGE	REF NO.	PART NO	PAGE	REF NO.	PART NO	PAGE	REF NO.
B3013141H0A	46	44	CQ200000000	28	24	HF0013050P0	68	28~30
B3120372000	2	41	CQ303000000	20	3	HF003000200	68	28~30
B3126012000	6	32	CS079073ASH	20	33	HK034610020	32	17
B3509210000	6	38	CS079073BSH	54	42	HK034610040	64	24
B3509210000	42	41	CS0800881TP	24	29	HK034640000	64	25
B3538112000	6	41	CS0800881TP	62	80	HK03464000B	32	18
B4022221D00	46	38	CS100081CSP	50	25	HN001490000	72	52
B471122000C	54	11	CS1000881TP	62	57	HN002460000	72	50
B471122000D	54	12	D7133555B00	6	33	HN002840000	72	51
B471122000E	54	35	D8001D15A0Y	78	5	HW002180200	68	15
B471122000F	54	36	D8002D15A0Y	78	6	HW200390000	32	20
B471122000G	54	13	D8204555D00	60	22	HW500070000	32	21
B471122000H	54	14	E2678453000	64	21	HX00056000A	38	22
B8101221DA0	60	1	E9567319000	70	40	HX00065000A	68	39
B8102221DA0	60	2	E9607603000	70	39	HX00150000B	30	65
B8103221DA0	60	3	EA9500B0100	6	44	HX00150000C	6	40
B8110373N00	60	10	EA9500B0100	10	44	HX00150000D	6	47
B8150221D00	60	4	EA9500B0100	26	51	HX00150000D	26	53
B8171223C00	60	19	EA9500B0100	28	44	HX00150000D	28	32
B8202205000	60	20	EA9500B0100	42	46	HX00150000D	48	48
B8267180000	12	57	EA9500B0100	46	47	HX00150000K	6	42
B9101490000	80	18	EA9500B0100	64	26	HX002330000	54	24
B9113012000	80	9	EA9500B0100	72	54	HX00233000B	54	23
B9121012000	60	21	EA9500B0100	78	19	HX00307000E	6	39
B91212200A0	80	12	EA9500B0100	80	24	HX00314000A	78	18
B9140372000	80	10	EA9500B0200	6	45	HX00326000K	70	11
B9141372000	82	9-10	G5151171000	60	23	HX003390000	12	49
BME01100000	68	21-23	G8124270000	64	19	HX003390000	70	21
BME03200000	68	21-23	GAF01007000	18	49	HX00339000M	72	60
BT0400251EB	54	34	GAT23301000	50	24	HX00354000B	68	12
BT0400251EB	78	22	GAW01502000	62	67	HX004070000	70	29
BT0600401EB	64	12	GCT02906000	82	9-10	HX00410000A	70	33
CM100100001	6	36	GEP01013000	78	20	HX005110000	70	38
CM200100001	70	46	GPK470010AB	74	5	KM000000480	70	24
CM300100003	68	24	GPK470010AB	78	2	KX000000210	70	47
CM300100401	68	20-41	HA005820000	68	17	KX000000230	72	48
CM300200003	6	2	HA006000000	32	19	M300451100A	68	27
CM300400601	68	22-25	HD000570000	46	30	M3801476000	70	9
CM300400701	68	22-25	HD00057000A	26	49	M4206461000	70	14
CM301200001	6	1	HD00057000A	38	16	M90195800A0	74	35-46
CM500100001	60	31	HD00057000A	46	33	M90295800A0	72	55
CM600100101	6	37	HD00057000A	74	18	M90345800A0	68	43
CM600100101	68	14	HD00204000A	42	35	MA011532000	68	31
CM600100101	72	57	HD00204000B	42	36	MC200501000	18	84~87
CM600100201	80	19	HF00130315S	68	28~30	MC200501002	80	4~7

NUMERICAL INDEX OF PARTS

PART NO	PAGE	REF NO.	PART NO	PAGE	REF NO.	PART NO	PAGE	REF NO.
MC372001100	18	84~87	PJ046052503	54	10	SB110002400	28	3
MC372001102	80	4~7	PJ301040501	78	13	SB110002400	40	52
MDP170B1800	18	84~87	PJ301040505	64	8	SB112001700	28	8
MDP170B1802	80	4~7	PJ301060003	64	13	SB120000900	16	1
MDP500B1400	18	84~87	PJ303040002	80	21	SB120001700	16	6
MDP500B1402	80	4~7	PJ304065101	64	35	SB120001800	16	4
MTJMS00000S	60	24	PJ305065202	64	20	SB130000200	50	30
MTSHJ100003	68	33	PJ308040002	78	27	SB130000300	50	31
NM3040520SC	70	26	PJ309520001	82	7	SB30700020A	16	29~32
NM6030001SC	34	24	PS0150065KP	14	15	SB30700020B	16	29~32
NM6030003SC	14	14	PS0150065KP	58	13	SB30700020C	16	29~32
NM6030003SC	44	48	PS0400082KP	60	41	SB30700020D	16	29~32
NM6040000SN	2	15	PS0400142KH	16	47	SB30800100A	28	33~36
NM6040001SC	60	63	PV010502000	78	12	SB30800100B	28	33~36
NM6040001SC	62	63	PV015211000	64	22	SB30800100C	28	33~36
NM6040001SC	82	15	PV135129000	64	34	SB30800100D	28	33~36
NM6040001SP	38	9	PV150209000	64	9	SB408000100	24	13
NM6040003SC	34	18	PV150209100	64	10	SB412000100	50	32
NM6050001SC	32	23	PV915005000	64	11	SD0350156TP	42	47
NM6050001SE	66	24	PX020002000	78	11	SD0400266TP	42	8
NM6050001SP	38	12	PX050003000	64	28	SD0600326TP	60	38
NM6050003SC	56	61	PX500014000	78	14	SD0601406TP	62	65
NM6060001SC	62	88	PX950009000	64	27	SD0800327TP	38	11
NM6060003SC	56	60	RC0100001KP	60	35	SD0800336TP	22	61
NM6060003SC	58	28	RC0370411KP	32	24	SD0800337TP	24	25
NM6060003SC	62	74	RC0560711KP	6	21	SD0800386TP	20	35
NM6080001SC	60	30	RC0650811KP	20	25	SD0800387TP	24	40
NM6080001SC	70	13	RC3781518KP	20	20	SD0800407TP	42	25
NM6080002SC	68	38	RE0200000K0	42	7	SD0800408TP	20	38
NM6080003SC	62	73	RE0300000K0	28	17	SD0800656TP	22	56
NM6080721SE	64	33	RE0300000K0	54	53	SD0800746TP	20	10
NM6100001SD	10	4	RE0300000K0	56	53	SD1000506TP	20	37
NM6120003SE	60	11	RE0320000K0	54	30	SK1382501SE	60	25
NS6090310SP	32	22	RE0400000K0	6	22	SK3311600SC	60	27
NS6110310SP	6	30	RE0500000K0	32	25	SK3413201SE	68	40
NS6110310SP	60	45	RE0700000K0	24	35	SK3452500SC	64	37
PA1602509A0	54	9	RE0800000K0	16	25	SK3512001SE	68	32
PA1602510A0	54	31	RE0900000K0	34	3	SK3582501SE	62	55
PB000010000	82	8	SB104001600	18	69	SL4030681SC	68	11
PC012401000	54	62	SB108000200	30	60	SL4030881SC	68	13
PC012401000	56	62	SB108000500	24	26	SL4031091SC	26	50
PF0552040B0	64	18	SB108000500	50	28	SL4031091SC	32	30
PF070501000	64	7	SB108002200	18	68	SL4031091SC	38	17
PJ025200003	64	23	SB108002300	18	72	SL4031091SC	46	34
PJ032052503	54	33	SB110001300	50	29	SL4032591SC	64	38

NUMERICAL INDEX OF PARTS

PART NO	PAGE	REF NO.	PART NO	PAGE	REF NO.	PART NO	PAGE	REF NO.
SL4040681SC	10	33	SM2360110TP	42	20	SM6040602TP	42	42
SL4040881SC	70	20·63·64	SM4020600SP	42	18	SM6040602TP	46	36
SL4040881SC	72	20·63·64	SM4021201SC	10	43	SM6040602TP	50	69
SL4040891SC	6	34	SM4030401SC	14	16	SM6040602TP	52	69
SL4040891SC	12	48	SM4030455SP	28	23	SM6040650TP	2	22
SL4040891SC	26	54	SM4030601SN	2	36	SM6040650TP	10	35
SL4040891SC	30	66	SM4030601SN	32	29	SM6040650TP	14	22
SL4040891SC	64	14	SM4040455SP	82	16	SM6040650TP	28	29
SL4040891SC	70	66	SM4040655SP	2	42	SM6040650TP	40	53
SL4040891SC	72	66	SM4040655SP	14	21	SM6040650TP	42	21
SL4041081SC	72	20·63·64	SM4040655SP	60	44	SM6040650TP	46	39
SL4041091SC	12	54	SM4040855SP	2	43	SM6040650TP	56	56
SL4041091SC	48	49	SM4040855SP	14	20	SM6040802TP	10	64
SL4041091SC	70	16·61·62	SM4040855SP	32	37	SM6040802TP	12	64
SL4041091SC	72	16·61·62	SM4041055SP	2	38	SM6040802TP	22	52
SL4041091SE	68	19	SM4041055SP	14	23	SM6040802TP	34	16
SL4043591SC	70	25	SM4041055SP	50	37	SM6040802TP	40	51
SL4051091SC	64	30	SM4041255SP	14	33	SM6040802TP	46	46
SL6040692TN	62	69	SM4041255SP	58	38	SM6040860TP	2	50
SL6040892TN	2	34	SM4041655SP	14	24	SM6040860TP	4	50
SL6040892TN	46	26	SM4042055SP	50	38	SM6040860TP	34	13
SL6041092TN	6	46	SM4050655SP	14	31	SM6040860TP	80	17
SL6041092TN	46	32	SM4050655SP	58	5	SM6041002TP	46	52
SL6041692TN	30	63	SM4050855SP	10	46	SM6041002TP	48	52
SL6052592TN	16	41	SM4050855SP	32	38	SM6041150TP	6	27
SL6052592TN	50	35	SM4051055SP	2	46	SM6041150TP	50	41
SL6061692TN	12	75	SM4051255SP	50	39	SM6041202TP	42	40
SL6061692TN	62	75	SM4051405SE	66	23	SM6041202TP	50	43
SL6062592TN	54	26	SM4051655SP	40	50	SM6041402TP	24	21
SL6083092TN	70	10	SM4061255SP	2	13	SM6041402TP	46	15
SL6084092TN	4	56	SM5040655SN	6	24	SM6041602TP	50	34
SL9061291SE	10	66	SM5040855SN	10	16	SM6041802TP	46	43
SL9061291SE	12	66	SM6020250TP	30	48	SM6041802TP	50	42
SL9061293SE	60	12	SM6020350SP	42	13	SM6050800SP	52	52
SL9082093SE	60	13	SM6020450TP	42	37	SM6050800SP	54	19
SL9082093SE	64	31	SM6020460TP	28	38	SM6050802TP	24	45
SM1030601SP	14	19	SM6030450TP	18	89	SM6050802TP	62	60
SM1030601SP	16	21	SM6030502TP	46	27	SM6051000SP	46	18
SM1040650TP	12	72	SM6030602TP	42	44	SM6051000SP	54	41
SM1040650TP	82	5	SM6030602TP	46	11	SM6051600SP	46	17
SM1040801SP	14	18	SM6030802TP	46	12	SM6051802TP	50	36
SM1040870TP	38	3	SM6040460TP	30	61	SM6051802TP	58	18
SM1040870TP	46	16	SM6040602TP	6	43	SM6060550TP	16	27
SM1040870TP	58	44	SM6040602TP	26	56	SM6060802TP	58	2
SM1041201SC	82	13	SM6040602TP	30	58	SM6061002TP	12	56

NUMERICAL INDEX OF PARTS

PART NO	PAGE	REF NO.	PART NO	PAGE	REF NO.	PART NO	PAGE	REF NO.
SM6061010TP	58	27	SM8061212TP	28	27	WP0450801SP	10	65
SM6061200SP	58	26	SM8061612TP	18	82	WP0450801SP	12	65
SM6061202TN	52	63	SM8061612TP	34	47	WP0450801SP	32	39
SM6061202TN	62	90	SM8480652TP	16	35	WP0450801SP	42	2
SM6061202TP	10	10	SM8480652TP	24	10	WP0450826SC	6	23
SM6061402TP	20	24	SM9050850SP	10	73	WP0450846SP	26	57
SM6061602TP	58	35	SM9050850SP	12	73	WP0450846SP	38	37
SM6061802TP	24	22	SM9051203CP	14	30	WP0482086SD	30	64
SM6061802TP	38	20	SM9087533SC	60	16	WP0482086SD	32	34
SM6084002TN	68	34	SS1060210TP	38	35	WP0482086SD	52	66
SM6086002TP	62	92	SS1110640TP	20	30	WP0501016SD	52	55
SM6107002TP	10	5	SS6090910SP	20	41	WP0520656SA	10	74
SM6450610TP	10	62	SS6110430TP	38	40	WP0520656SA	12	74
SM6450610TP	12	62	SS6111210SP	78	7~10	WP0520656SA	24	38
SM7030450SC	14	17	SS7090410SP	38	33	WP0522016SH	24	39
SM7751160TP	22	51	SS7110740TP	38	39	WP0522016SH	62	83
SM8030412TP	18	63	SS7111120TP	78	28~30	WP0531000SD	14	32
SM8030412TP	34	7	SS7111810TP	20	42	WP0531000SD	46	22
SM8040310SS	18	53	SS8110410TP	20	34	WP0531000SD	52	67
SM8040412TP	4	51	SS8110422TP	56	49	WP0531000SD	54	29
SM8040412TP	32	26	TA0550604R0	22	57	WP0531000SD	58	6
SM8040802TP	6	26	TA0670604R0	16	19	WP0531001SC	32	40
SM8050412TP	24	43	TA0750404R0	20	21	WP0531001SC	52	59
SM8050412TP	50	45	TA0850604R0	2	23	WP0531001SC	66	22
SM8050412TP	62	81	TA1050504R0	2	24	WP0553216SD	78	7~10
SM8050502TP	6	25	TA1250406R0	2	25	WP0611626SP	20	9
SM8050512TP	58	42	TA2351004R0	2	27	WP0611626SP	58	32
SM8050592TP	38	21	WP0320500SC	42	6	WP0612056SD	12	71
SM8050812TP	50	46	WP0320500SD	46	19	WP0641600SC	58	36
SM8050812TP	54	27	WP0320501SC	32	31	WP0641601SD	58	29
SM8060602TP	24	19	WP0320501SD	42	45	WP0650876SD	54	39
SM8060602TP	50	48	WP0320501SD	46	20	WP0651001SC	10	11
SM8060602TP	52	48	WP0330501SB	14	25	WP0651001SC	38	47
SM8060610TP	28	46	WP0430800SC	22	54	WP0651001SC	52	64
SM8060802TP	52	49	WP0430801SC	34	10	WP0651056SD	58	30
SM8060812TP	10	6	WP0430801SC	52	56	WP0820516SP	16	15
SM8060812TP	16	43	WP0430801SC	82	14	WP0820816SD	54	47
SM8060812TP	20	66	WP0431005SP	54	43	WP0841600SE	60	28
SM8060812TP	22	66	WP0431005SP	62	66	WP0841601SC	68	36
SM8060812TP	24	34	WP0450000SD	52	68	WP0841601SC	70	42
SM8060812TP	28	11	WP0450000SD	58	39	WP0850002SP	24	14
SM8060812TP	38	14	WP0450801SD	2	44	WP0850002SP	62	94
SM8060812TP	52	51	WP0450801SD	14	27	WP0852086SC	68	35
SM8060812TP	58	25	WP0450801SD	30	62	WP0871602SE	64	32
SM8061050TP	30	50	WP0450801SD	78	28~30	WP1022016SH	62	59

NUMERICAL INDEX OF PARTS

PART NO	PAGE	REF NO.
WP1052001SC	10	7
WP1221016SP	20	27
WP1612616SE	66	15
WS0410002KN	52	57
WS0451040KP	78	28~30
WS0510002KN	66	21
WS0610002KP	58	31
WS0610002KP	62	89
WS0820002KN	60	93
WS0820002KN	62	93
WS0820002KR	68	37
WS1020002KN	10	8
WZ0850302K0	24	28